

# PESTAN

we build trust

## Каталог Решения для дома

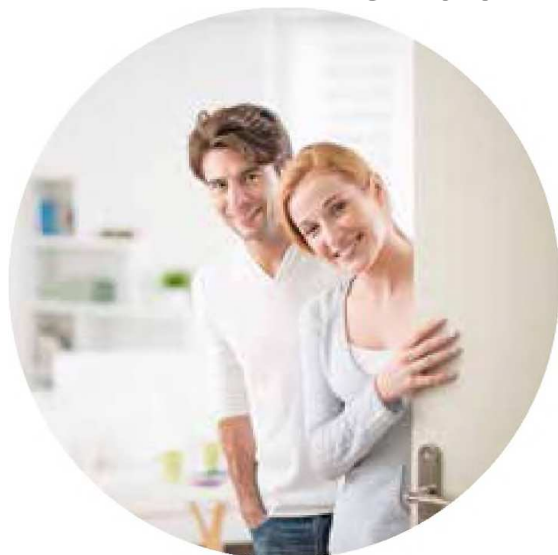

По вопросам продаж и поддержки обращайтесь:

Алматы (7273)495-231  
Ангарск (3955)60-70-56  
Архангельск (8182)63-90-72  
Астрахань (8512)99-46-04  
Барнаул (3852)73-04-60  
Белгород (4722)40-23-64  
Благовещенск (4162)22-76-07  
Брянск (4832)59-03-52  
Владивосток (423)249-28-31  
Владикавказ (8672)28-90-48  
Владимир (4922)49-43-18  
Волгоград (844)278-03-48  
Вологда (8172)26-41-59  
Воронеж (473)204-51-73  
Екатеринбург (343)384-55-89

Иваново (4932)77-34-06  
Ижевск (3412)26-03-58  
Иркутск (395)279-98-46  
Казань (843)206-01-48  
Калининград (4012)72-03-81  
Калуга (4842)92-23-67  
Кемерово (3842)65-04-62  
Киров (8332)68-02-04  
Коломна (4966)23-41-49  
Кострома (4942)77-07-48  
Краснодар (861)203-40-90  
Красноярск (391)204-63-61  
Курск (4712)77-13-04  
Курган (3522)50-90-47  
Липецк (4742)52-20-81

Магнитогорск (3519)55-03-13  
Москва (495)268-04-70  
Мурманск (8152)59-64-93  
Набережные Челны (8552)20-53-41  
Нижний Новгород (831)429-08-12  
Новокузнецк (3843)20-46-81  
Ноябрьск (3496)41-32-12  
Новосибирск (383)227-86-73  
Омск (3812)21-46-40  
Орел (4862)44-53-42  
Оренбург (3532)37-68-04  
Пенза (8412)22-31-16  
Петрозаводск (8142)55-98-37  
Псков (8112)59-10-37  
Пермь (342)205-81-47

Ростов-на-Дону (863)308-18-15  
Рязань (4912)46-61-64  
Самара (846)206-03-16  
Санкт-Петербург (812)309-46-40  
Саратов (845)249-38-78  
Севастополь (8692)22-31-93  
Саранск (8342)22-96-24  
Симферополь (3652)67-13-56  
Смоленск (4812)29-41-54  
Сочи (862)225-72-31  
Ставрополь (8652)20-65-13  
Сургут (3462)77-98-35  
Сыктывкар (8212)25-95-17  
Тамбов (4752)50-40-97  
Тверь (4822)63-31-35

Тольятти (8482)63-91-07  
Томск (3822)98-41-53  
Тула (4872)33-79-87  
Тюмень (3452)66-21-18  
Ульяновск (8422)24-23-59  
Улан-Удэ (3012)59-97-51  
Уфа (347)229-48-12  
Хабаровск (4212)92-98-04  
Чебоксары (8352)28-53-07  
Челябинск (351)202-03-61  
Череповец (8202)49-02-64  
Чита (3022)38-34-83  
Якутск (4112)23-90-97  
Ярославль (4852)69-52-93

Россия +7(495)268-04-70

Казахстан +7(7172)727-132

Киргизия +996(312)96-26-47

почта: [pad@nt-rt.ru](mailto:pad@nt-rt.ru) || сайт: <https://pestan.nt-rt.ru/>

---

Production facilities of company Peštan are located in Arandjelovac, Serbia. Annual revenue exceeding 70 million EUR, which is realized with the help of 1,000 employees. Peštan has a direct presence, through its daughter companies, in Bosnia and Herzegovina, as well as in Romania and through its representative offices in Albania, Croatia and the United Arab Emirates. Peštan operates in more than 60 countries worldwide through a global network of agents and distributors. Primarily export-oriented, the company is present in the market of Europe, Russia, Middle East, North Africa, Latin America and the United States. The entire production is adjusted to European standards which is proved by international

certificates for quality products: DVGW, MPA, SABS, IMS, IGH, ZIK, VUPS, EMI, and certificates of quality process ISO 9001, ISO 14001, OHSAS 1800. For maximum satisfaction of customer needs, the company is constantly innovating and improving personnel and equipment. Since 2009, the company introduced the SAP ERP modules MM, SD, PP, FI CO, and since 2012 have extended functionality and WMS was included. The introduction of WCM and WMS system has increased the efficiency, contributed to the allocation of costs and professional maintenance. Central warehouse Peštan company is located in Arandjelovac in Serbia, which is sized and designed to meet the requirements of the most

demanding customers who want efficient and reliable delivery of products. To respond to these requirements, Peštan has 14 000 m<sup>2</sup> of closed storage space for finished and semi-finished products 5,000 m<sup>2</sup> warehouse for raw materials and intermediate goods, and approximately 50,000 m<sup>2</sup> of open storage space. Indoor storage space equipped with shelves with over 21,000 pallet positions. Our vision is to be recognized as a leader in the Balkans, which provides customers with diversified solutions and products in one place. Our mission is creating a competitive advantage in our customers' businesses with the help of first-class solutions, services and products. We provide our company's success by consistently meeting the needs of clients, stakeholders and employees.





# KEY FACTS

**60**

AND MORE  
COUNTRIES  
WHERE WE EXPORT  
OUR PRODUCTS

**6,500**

DIFFERENT PRODUCTS  
IN OUR PRODUCTION  
ASSORTMENT

**50,000**

TONS OF MATERIAL  
PROCESSED  
ANNUALLY



# WINDOWS

## For high quality PVC joinery Pestan provides the **THIRD SEALING** -Triple sealing is solved by inserting the support (clip) in the frame profile!

"PEŠTAN" DEVELOPED PVC JOINERY THAT FULLY MEETS LATEST EUROPEAN STANDARDS AND MODERN CRITERIA AND OFFERED TO CUSTOMERS AFFORDABLE PRICE FOR REAL VALUE AND PRODUCTS.

- **CHAMBER SYSTEM** - Five chambers ensure isolation. Coefficient ideal heat transfer  $K = 0.98 \text{ W / m}^2\text{K}$  with low-emission glass in variant width 24mm and 28 mm.
- The German technology of PVC profiles.
- ECO-PROFILE CaZn stabilizer (Absence of Lead).
- German certificate for profile and finished product.

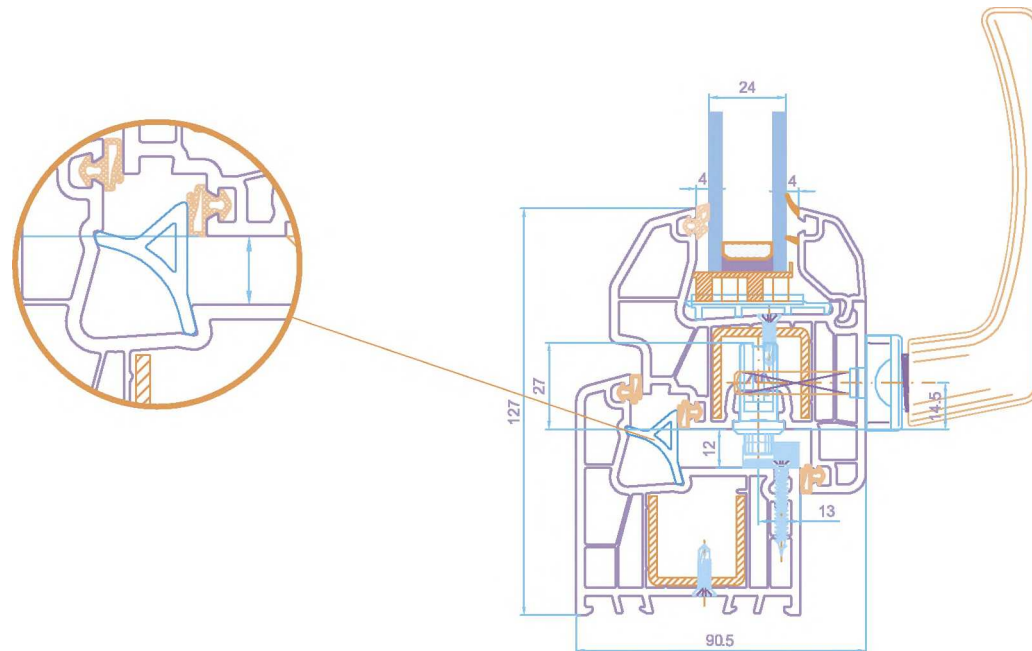

In addition to the standard dimensions, they can be made towards the joinery wishes and requirements of the customer. Also, if desired, required glass that a customer requests can be implemented (all types and thickness of glass) as well as decorative panels for entrance doors.

- OSHACKLE -USE OF SHACKLES OF RENOWNED MANUFACTURERS SUCH AS SIGENIA, ROTO, VABIS ...
- HEAT TRANSFER COEFFICIENT  $K = 0.98 \text{ W / M}^2\text{K}$
- MACHINES FOR MAKING JOINERY BY KNOWN MANUFACTURER ELUMATEC
- POSSIBLE DOMESTIC OR CENTRAL SEALING SYSTEM
- INTERCHANGEABLE RUBBER (POSSIBILITY OF REPLACING SEAL)
- DRAIN CONDENSATE THROUGH THE SPECIAL CHAMBER
- CHAMBER SYSTEM - CHAMBER OF FIVE PARTS PROVIDES AN EXCELLENT INSULATION





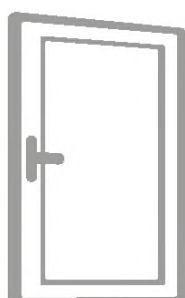
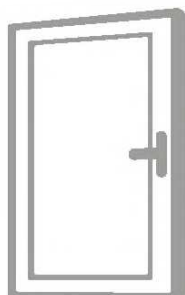

#### SINGLE WINDOW

MATERIAL CODE	DIMENSIONS (WIDTH X HEIGHT)
40002460	60 x 60 LEVI
40002461	60 x 60 DESNI
40002462	60 x 80 LEVI
40002463	60 x 80 DESNI
40002464	80 x 100 LEVI
40002465	80 x 100 DESNI
40002466	80 x 120 LEVI
40002467	80 x 120 DESNI
40002468	100 x 100 LEVI
40002469	100 x 100 DESNI
40002470	100 x 120 LEVI
40002471	100 x 120 DESNI
40002472	80 x 140 LEVI
40002473	80 x 140 DESNI
40002475	100 x 140 LEVI
40002476	100 x 140 DESNI
40002477	120 x 120 LEVI
40002478	120 x 120 DESNI

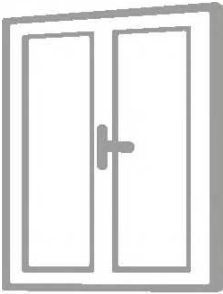

#### DOUBLE WINDOW

MATERIAL CODE	DIMENSIONS (WIDTH X HEIGHT)
40002479	120 x 120
40002480	120 x 140
40002481	140 x 140
40002482	140 x 120
40002483	160 x 140

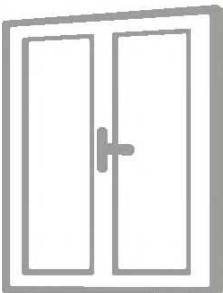

#### DOUBLE WINDOW WITH MIDDLE PILLAR

MATERIAL CODE	DIMENSIONS (WIDTH X HEIGHT)
40002484	120 x 120

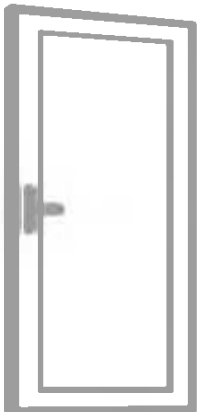

#### SINGLE BALCONY DOOR

MATERIAL CODE	DIMENSIONS (WIDTH X HEIGHT)
40002485	80 x 210 LEVA
40002486	80 x 210 DESNA
40002487	80 x 220 LEVA
40002488	80 x 220 DESNA

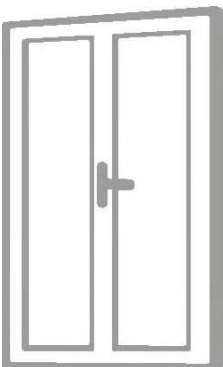

#### DOUBLE BALCONY DOOR

MATERIAL CODE	DIMENSIONS (WIDTH X HEIGHT)
40002489	140 x 210
40002490	160 x 210
40002491	140 x 220





# PVC PROFILES

S-509 / Production Programme

## INTRODUCTION

We have the honour to present to you our PVC profile, which has been made in accordance with world standards for the first time on our market. not only with regard to quality, but also with regard to environmental protection (EKOPROFIL). In accomplishing this project. we have contacted world renowned companies which have been developing PVC joinery and materials for the profile's construction. Greiner from Austria participated in the development of our system as the producer and manufacturer of tools, and the German company Baerlocher participated as the producer of materials used in the profile's production. During the system's construction we were governed by the idea that the buyer deserves the highest quality profile, with excellent thermal isolation qualities, state of art ecological characteristics, and easy assembly and maintenance, at a price adjusted to our circumstances.

---

## EXTRUSION OF PVC PROFILES

In 2006, we started developing our own PVC profile system for making joinery. In the development of this project, besides the extraordinary mechanical and thermal isolation characteristics of the profiles, a great deal of attention was paid to ecological awareness, the selected technology being the latest available on the market and ecologically safe as well.

IN TIMES WHEN PEOPLE ARE BECOMING INCREASINGLY ECOLOGICALLY AWARE OF THE HARM DONE TO NATURE BY MAN THROUGH HIS ACTIONS, PESTAN PROFILES, STABILIZED BY A CALCIUM-ZINC STABILIZER, REPRESENTS THE IDEAL SOLUTION.

#### CHARACTERISTICS

- 5 chamber system, 70 mm construction depth
- Possible inner or central sealing system
- Changeable rubbers
- Condensation drain through a separate chamber
- Visible or hidden drains for condensation outflow
- Lowered edges on the frame and wing
- Application of standard studs
- 16 mm Eurogroove
- Spacious chamber for steel reinforcement
- Fixing of bearing reinforcements through two profile walls
- Fixing of studs through steel reinforcement
- Covering with 24 mm or 28 mm glass
- Easy construction and assembly
- Possible installation of fixed glass into the frame
- Mechanical fixing onto wall through steel reinforcements





We provide the producers of PVC joinery with maximum technical support and we are always available if technical problems need to be



---

#### THE BEST SERBIAN EXTRUDED PVC PROFILE

---

This is confirmed by the internationally recognized certificate of the famous German institute "SKZ". PESTAN profiles belong to the highest quality A class of profiles and fulfil the requirements of the European Standard 12608, which means that they can be sold on all world markets. Because of this, the profile is already being exported to several European Union countries, as well as to all the republics of the former-Yugoslavia.

---

#### THE TESTING PROCESS

---

During the testing of Pestan profiles at the German "SKZ" Institute, the profile has undergone a large number of tests in order to examine its characteristics in detail. The most demanding test passed successfully by our profile was the artificial ageing test. During this test, the profile was alternately exposed to radiation from special XENON lamps, then sprinkled with water, dried for a brief period and then again exposed to light from the xenon lamps. This procedure lasts over six months and simulates 50 years of natural conditions. After the artificial ageing treatment, the profile was then exposed to testing of its mechanical characteristics, i.e. its strike resistance and colour resistance. Due to the ecological Calcium- Zinc stabilizer which we use, our profile was significantly within the values required by the European Standard 12608 after the artificial ageing process which simulates 50 years of aging.



## TECHNOLOGY

PVC (polyvinylchloride) is a versatile polymer which can be solid or flexible depending on its processing. However, its processing requires the use of stabilizers which make it resistant to the high temperatures and mechanical stress to which it is exposed in the extrusion or spurling process. These additives prevent changes in the chemical structure of PVC, which would otherwise prevent any processing. During the past few decades, lead stabilizers were used in the majority of products made from solid PVC worldwide, except in the North America, where the dominant stabilizers are those based on tin. Both systems have a similar relation to price-quality. However, they are mutually incompatible and cannot be recycled together; therefore they are used in different markets. Since lead stabilizers, which dominated the European market so far, have been pronounced unwelcome on European soil, because lead is poisonous if introduced into the body, another solution had to be found. It was obtained through Calcium-Zinc stabilizers.

## STABILIZATION COMPONENTS

The extruded PVC profiles obtained through the fulfilment of all these conditions are a product with excellent physical characteristics, which fulfil the most demanding economic and ecological requirements. Because of this, the Pestan company entrusted the famous German producer Baerlocher with the production and constant monitoring of the ingredients, due to its long years of experience producing top components for PVC stabilization. Stability under all weather conditions is extremely important for PVC stabilization. Tests point out that Calcium-Zinc profiles are more resistant to changes in colour than the classic lead system. This is particularly important for coloured profiles, since it enables higher colour durability over a longer period. Bearing all of these facts in mind, the Pestan company developed its system of PVC joinery which completely fulfils the latest European standards and modern criteria, and offered it to customers who wish to obtain real value and a product at a favourable price.

# PVC PROFILES S-509

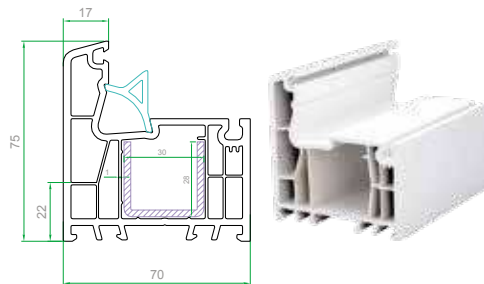

**FRAME S-509.01**

CODE 12000000

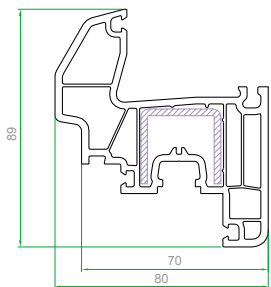

**WING S-509.02**

CODE 12000100

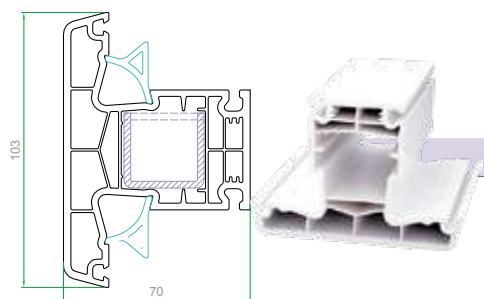

**CENTRAL PILLAR S-509.03**

CODE 12000200

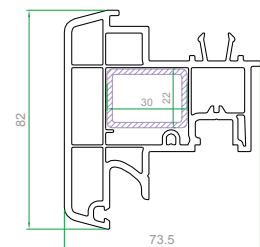

**FOLDING LATH S-509.04**

CODE 12000300

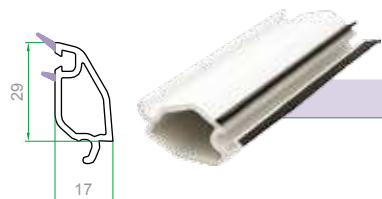

**GLASS LATH 28MM S-509.06**

CODE 12000500

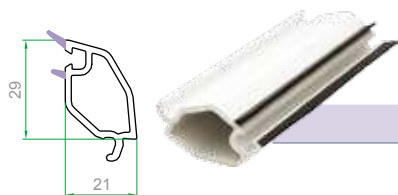

**GLASS LATH 24MM S-509.07**

CODE 12000600

S-509.08 Z WING OF ENTRANCE DOOR

CODE 12000700

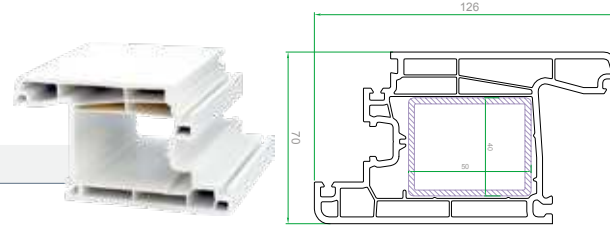

S-509.09 T WING OF ENTRANCE DOOR

CODE 12000800

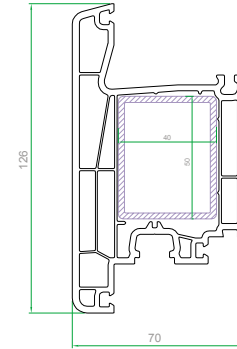

S-509.11 CONTINUED DOORWAY

CODE 12001000

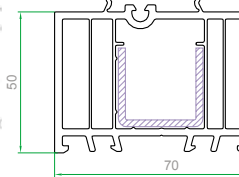

S-509.10 SOLBANK

CODE 12000900

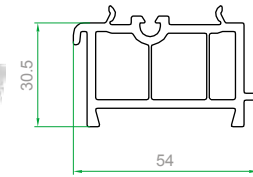

S-509.05 CLIPS

CODE 12000400

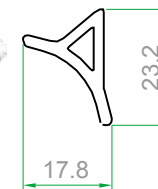

S-509.12 CONNECTING LATH

CODE 12001100



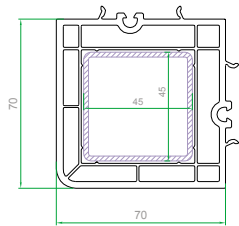

**CORNER PROFILE S-509.13**

CODE 120001200

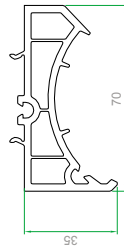

**SEMI-CIRCULAR CLAMP S-509.14**

CODE 12001300

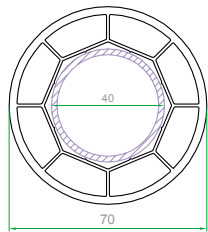

**PIPE S-509.15**

CODE 12001400

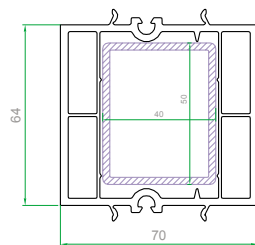

**REINFORCEMENT PROFILE S-509.016**

CODE 12001500

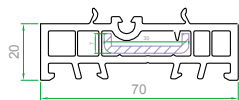

**DOORWAY EXTENSION 20MM S-509.30**

CODE 12002900

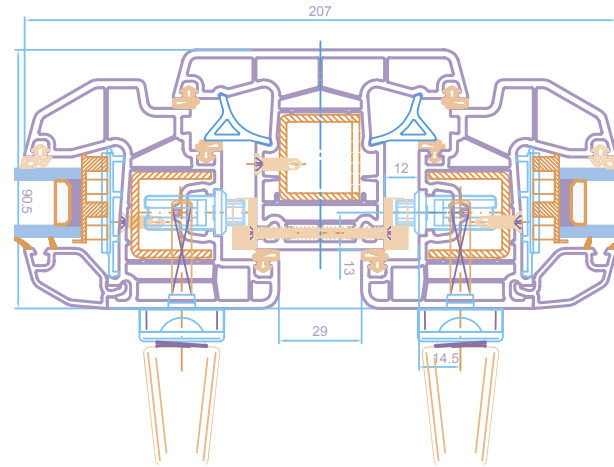
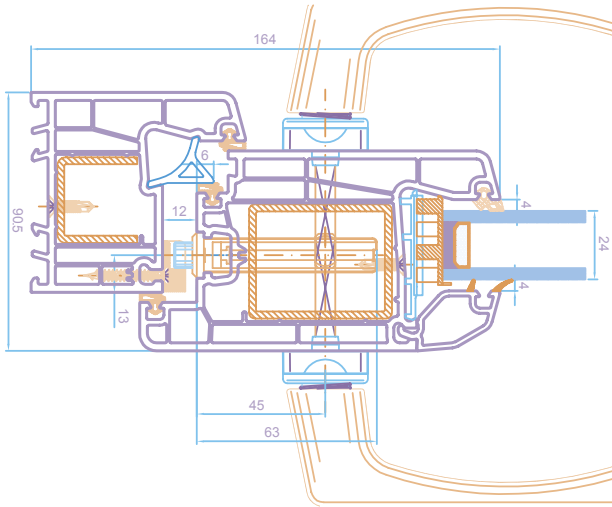

#### WORLD TRENDS

It is a trend today to use stabilizers based on Calcium (Ca) and Zinc (Zn) as well as some organic components. Such a programme is significant progress in the fulfilment of the new economic objectives and environmental protection by the European PVC sector. Stabilizers based on Calcium-Zinc give some production advantages in relation to lead and tin stabilizers. They combine easy handling with good product characteristics and give excellent durability during exposure to weather conditions. On the other hand, they are specific and often require special adjustments depending on the individual application. The manufacture of tools is also specific, with the tools requiring specific additional processing on the producer's location to give maximum quality with the ingredients used by the producer.

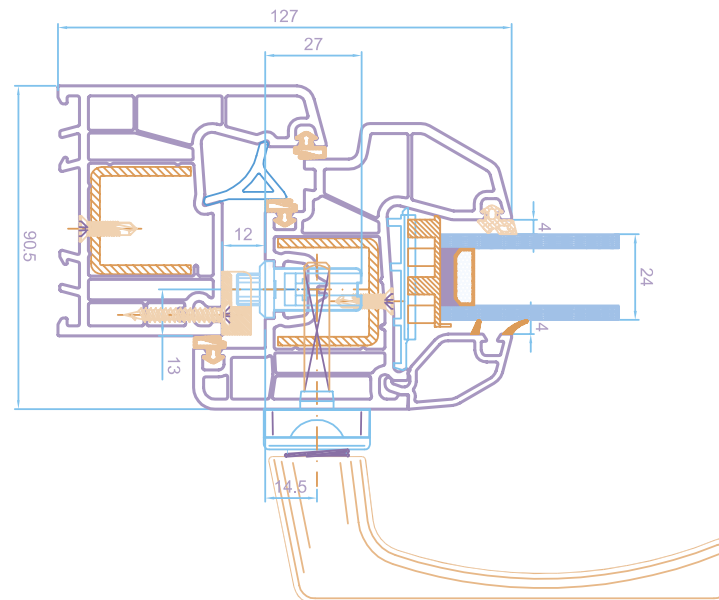
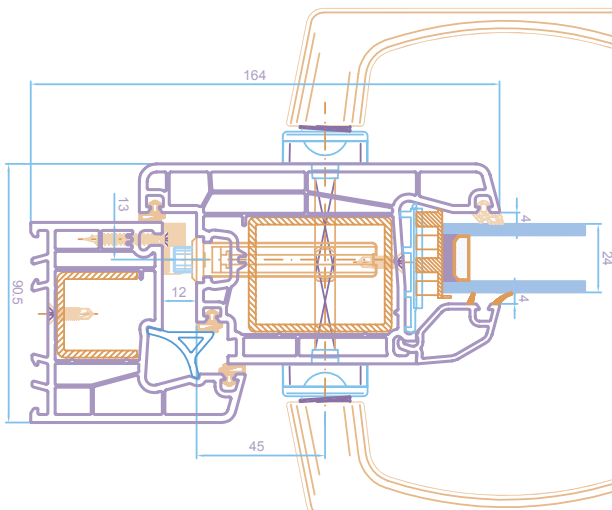

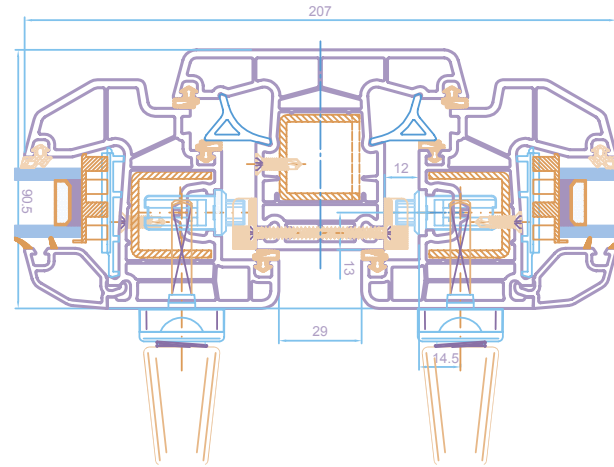
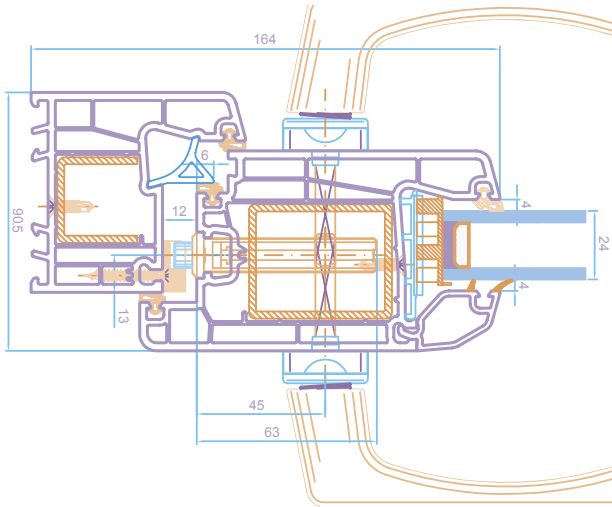

#### WORLD TRENDS

It is a trend today to use stabilizers based on Calcium (Ca) and Zinc (Zn) as well as some organic components. Such a programme is significant progress in the fulfilment of the new economic objectives and environmental protection by the European PVC sector. Stabilizers based on Calcium-Zinc give some production advantages in relation to lead and tin stabilizers. They combine easy handling with good product characteristics and give excellent durability during exposure to weather conditions. On the other hand, they are specific and often require special adjustments depending on the individual application. The manufacture of tools is also specific, with the tools requiring specific additional processing on the producer's location to give maximum quality with the ingredients used by the producer.

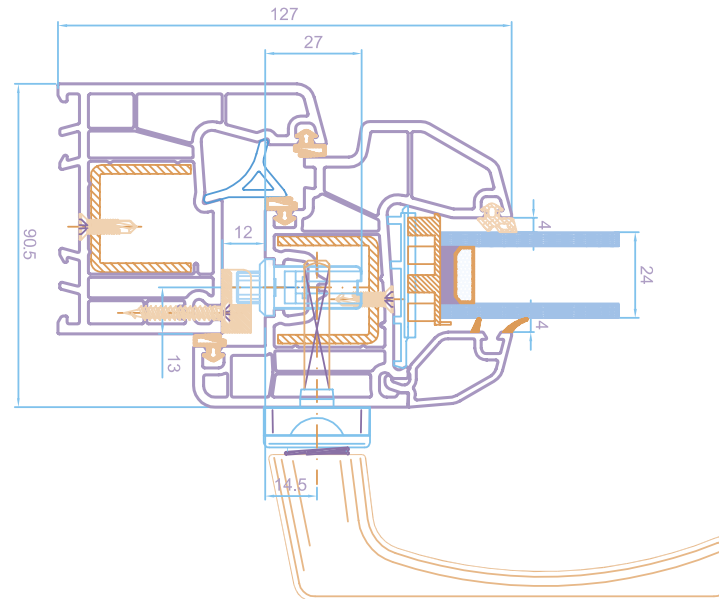
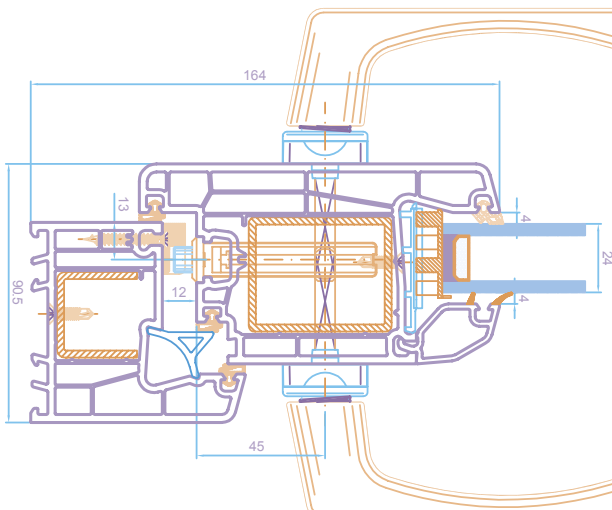





# GARBAGE CANS

120L/240L

# GARBAGE CAN

## 120L

### CHARACTERISTICS

---

- Garbage can volume: 120l
- Garbage can dimensions: (LxWxH) 560x480x940
- Maximum load capacity of the garbage can: 100 ± 5 kg
- Garbage can weight: 9,5 ± 3,2 kg
- Garbage can is made of high density polyethylene (HDPE)
- Wheel axle is made of stainless steel
- number of wheels: 2 wheels
- Thermal stability -18° C to +23° C
- Diameter 200mm, with plastic rims
- Load bearing capacity per wheel: 160 kg, proved by testing report
- Weight of loaded garbage 60 kg

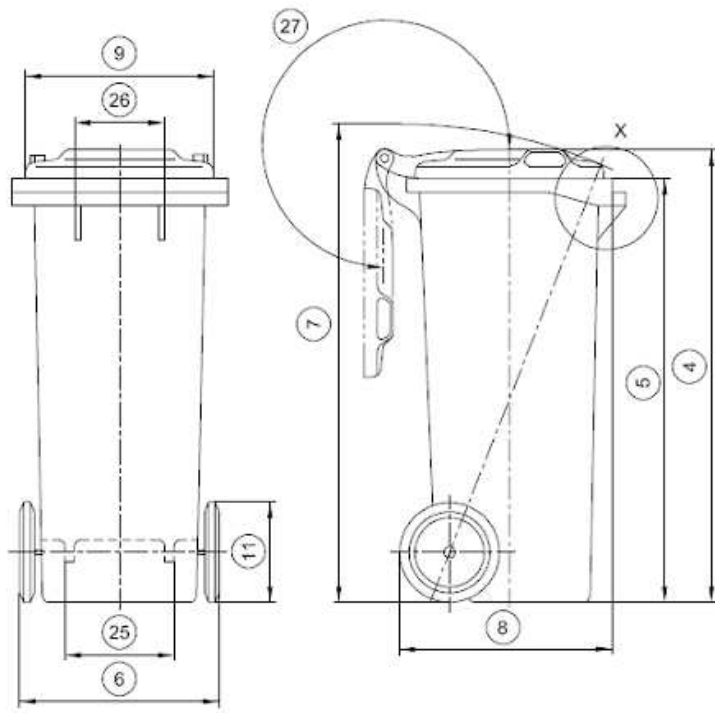

- 
- Garbage can is constructed with reinforcement for lifter of garbage disposal truck, by which the garbage can is automatically discharged.

- Garbage can has a handle that enables easy handling.



- 
- Possibility of placing openings for the separation: PET, paper, cans and glass.



- 
- The possibility of making labels on request.



- 
- Garbage can is made with smooth outer and inner surface.
- 
- Garbage can is produced in chrome green colour, with option of manufacturing them in other colours on buyers request.
- 
- Markings with serial number can be arranged on buyers request.
- 
- Garbage can is made of recyclable material.
- 
- Garbage can is manufactured according to demands of the standard EN 840, and fully meets the required characteristics.
- 
- Garbage can is resistant to acids and organic alkaline thinners.

TESTS:

Cans satisfy the requirements of European norms by which have been made and tested.

TEST of impact EN 840-5 at point 4.7.2.

TEST of falling EN 840-5 at point 4.7.5.

TEST of stability EN 840-5 at point 4.8.

TESTING of aging EN 840-5 at point 4:11:10

# GARBAGE CAN

## 140L

### CHARACTERISTICS

---

- Garbage can volume: 140l
- Garbage can dimensions: (LxWxH) 550x480x1060
- Maximum load capacity of the garbage can: 115 kg
- Garbage can weight:  $10 \pm 2$  kg
- Garbage can is made of high density polyethylene (HDPE)
- Wheel axle is made of stainless steel
- number of wheels: 2 wheels
- Thermal stability  $-18^{\circ}\text{C}$  to  $+23^{\circ}\text{C}$
- Diameter 200mm, with plastic rims
- Load bearing capacity per wheel: 160kg, proved by testing report
- Weight of loaded garbage 70 kg

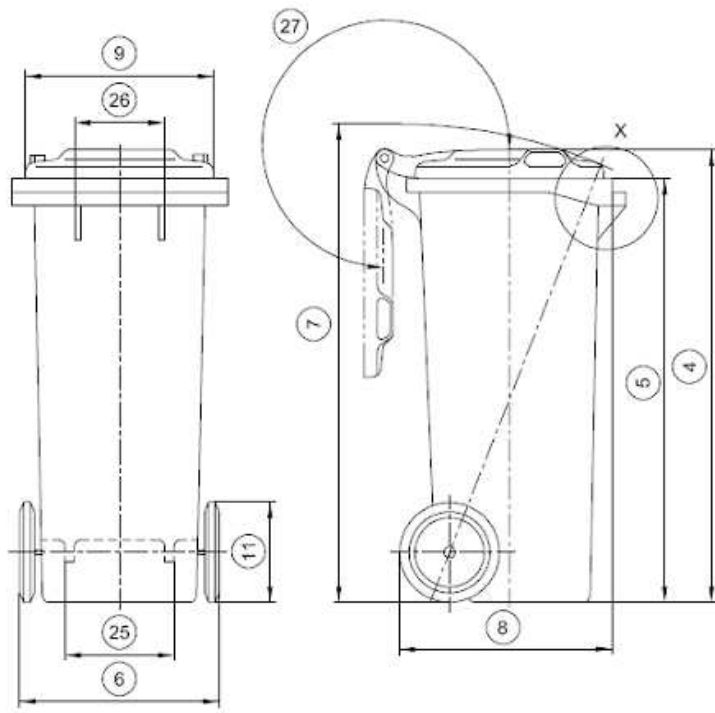

- Garbage can is constructed with reinforcement for lifter of garbage disposal truck, by which the garbage can is automatically discharged.

- Garbage can has a handle that enables easy handling.



- Possibility of placing openings for the separation: PET, paper, cans and glass.



- The possibility of making labels on request.





- 
- Garbage can is made with smooth outer and inner surface.
- 
- Garbage can is produced in chrome green colour, with option of manufacturing them in other colours on buyers request.
- 
- Markings with serial number can be arranged on buyers request.
- 
- Garbage can is made of recyclable material.
- 
- Garbage can is manufactured according to demands of the standard EN 840, and fully meets the required characteristics.
- 
- Garbage can is resistant to acids and organic alkaline thinners.

TESTS:

Cans satisfy the requirements of European norms by which have been made and tested.

TEST of impact EN 840-5 at point 4.7.2.

TEST of falling EN 840-5 at point 4.7.5.

TEST of stability EN 840-5 at point 4.8.

TESTING of aging EN 840-5 at point 4:11:10

# GARBAGE CAN 240L

## CHARACTERISTICS

---

- Garbage can volume: 240l
- Garbage can dimensions: (LxWxH) 710x580x1060mm
- Gross permitted mass 110kg
- Weight of can: 11.45kg
- Can is made of high density polyethylene (HDPE)
- Axle for wheels, stainless steel / 2 pcs
- Temperature resistance **-18 °C** up to **+23 °C**
- The wheels are solid rubber Ø 200 mm diameter with plastic rim
- Increased body cans
- UV stability

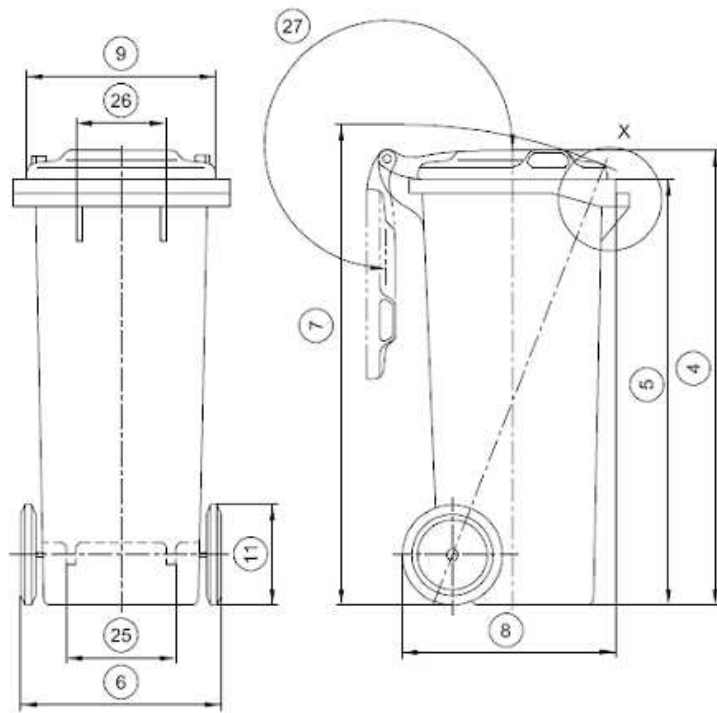

- Bin is constructed so that there is reinforcement for the comb grabbing of garbage trucks with which the bucket is emptied



- Bin has a grip which enables easy handling



- Bins with smooth external and internal surfaces
- Bin is green and there is a possibility of making them in different colors according to customer
- At the customer's request bins may be marked by serial number. **015000**
- The material cans are made of can be recycled
- Can is made according to standard EN 840-2: 2013 Section 1, 5 and 6 and in full comply with prescribed characteristics
- The possibility of making labels on request.

- The colors in which the bin is produced (all colors are available on customer request)



- The possibility of setting hole separation: PET, paper, cans and glass.



## CAN LABELING ACCORDING TO EN 840-1:2013



Producer label on the left side of the body



European norm, nominal volume and mass are on the right side of the body



ILID INFORMATION

- Do not dispose flammable objects
- Noise level
- CE sign
- Recycling sign

Year and month of production, material label is on the bottom side of the body



Year and month of production are on the right side of the bin's body



Frontal label for grabbing and lifting the bin (A)  
Bin name (Container)

- LAST COUNT IN THE TABLE PRESENTS THE YEAR AND MONTH OF PRODUCTION CANS



VATS

Pestan company for many years manufactures polyethylene vats for liquids or bulk materials in agriculture and household. Vats, in addition to the water you can use in the production of wines and rakija as well as other household purposes in accordance with the chemical resistance of materials and at room temperature. In case you have need for storing liquids at elevated temperatures or concentrated chemicals please consult the manufacturer



PESTAN VATS ARE MANUFACTURED IN FOLLOWING VOLUMES:

- 100 Ivat without cover
- 200 Ivat with optional cover
- 500 Ivat with optional cover
- 1000l vat without cover. Vats are standardly made in dark green color.



Pestan plastic vats are made of high density polyethylene. They are intended for the storage of liquids and bulk materials in accordance with the chemical resistance of materials. Although polyethylene is resistant to virtually all chemical influences, we ask customers that in the event of industrial applications, storage of concentrated chemicals and storing liquids at elevated temperatures should consult the manufacturer. Also it is very important before first use to make appropriate set up and levelate vat. Since the vat in operation carries very heavy load incorrect installation can result in breakage and emphasizing liquids.

#### THE DIMENSIONS OF THE VAT:

- 200 I - height 79 cm diameter 68 cm
- 500 I - height 90 cm diameter 101 cm
- 1000 I - height 96 cm diameter 134 cm

For vats 200 I and 500 I have to offer and the appropriate covers.

PESTAN creates eco friendly products designed to have the less possible impact on surroundings in all aspects of its life cycle, establishing independent eco standards (standards for environmentally friendly products) for each product



## По вопросам продаж и поддержки обращайтесь:

Алматы (7273)495-231  
Ангарск (3955)60-70-56  
Архангельск (8182)63-90-72  
Астрахань (8512)99-46-04  
Барнаул (3852)73-04-60  
Белгород (4722)40-23-64  
Благовещенск (4162)22-76-07  
Брянск (4832)59-03-52  
Владивосток (423)249-28-31  
Владикавказ (8672)28-90-48  
Владимир (4922)49-43-18  
Волгоград (844)278-03-48  
Вологда (8172)26-41-59  
Воронеж (473)204-51-73  
Екатеринбург (343)384-55-89

Иваново (4932)77-34-06  
Ижевск (3412)26-03-58  
Иркутск (395)279-98-46  
Казань (843)206-01-48  
Калининград (4012)72-03-81  
Калуга (4842)92-23-67  
Кемерово (3842)65-04-62  
Киров (8332)68-02-04  
Коломна (4966)23-41-49  
Кострома (4942)77-07-48  
Краснодар (861)203-40-90  
Красноярск (391)204-63-61  
Курск (4712)77-13-04  
Курган (3522)50-90-47  
Липецк (4742)52-20-81

Магнитогорск (3519)55-03-13  
Москва (495)268-04-70  
Мурманск (8152)59-64-93  
Набережные Челны (8552)20-53-41  
Нижегород (831)429-08-12  
Новокузнецк (3843)20-46-81  
Ноябрьск (3496)41-32-12  
Новосибирск (383)227-86-73  
Омск (3812)21-46-40  
Орел (4862)44-53-42  
Оренбург (3532)37-68-04  
Пенза (8412)22-31-16  
Петрозаводск (8142)55-98-37  
Псков (8112)59-10-37  
Пермь (342)205-81-47

Ростов-на-Дону (863)308-18-15  
Рязань (4912)46-61-64  
Самара (846)206-03-16  
Санкт-Петербург (812)309-46-40  
Саратов (845)249-38-78  
Севастополь (8692)22-31-93  
Саранск (8342)22-96-24  
Симферополь (3652)67-13-56  
Смоленск (4812)29-41-54  
Сочи (862)225-72-31  
Ставрополь (8652)20-65-13  
Сургут (3462)77-98-35  
Сыктывкар (8212)25-95-17  
Тамбов (4752)50-40-97  
Тверь (4822)63-31-35

Тольятти (8482)63-91-07  
Томск (3822)98-41-53  
Тула (4872)33-79-87  
Тюмень (3452)66-21-18  
Ульяновск (8422)24-23-59  
Улан-Удэ (3012)59-97-51  
Уфа (347)229-48-12  
Хабаровск (4212)92-98-04  
Чебоксары (8352)28-53-07  
Челябинск (351)202-03-61  
Череповец (8202)49-02-64  
Чита (3022)38-34-83  
Якутск (4112)23-90-97  
Ярославль (4852)69-52-93

Россия +7(495)268-04-70

Казахстан +7(7172)727-132

Киргизия +996(312)96-26-47

почта: [pad@nt-rt.ru](mailto:pad@nt-rt.ru) || сайт: <https://pestan.nt-rt.ru/>