

# Peštan

## КАТАЛОГ Решения для трубопроводов

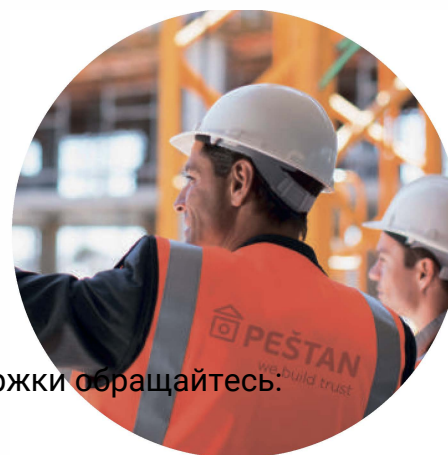

По вопросам продаж и поддержки обращайтесь.

Алматы (7273)495-231  
Ангарск (3955)60-70-56  
Архангельск (8182)63-90-72  
Астрахань (8512)99-46-04  
Барнаул (3852)73-04-60  
Белгород (4722)40-23-64  
Благовещенск (4162)22-76-07  
Брянск (4832)59-03-52  
Владивосток (423)249-28-31  
Владикавказ (8672)28-90-48  
Владимир (4922)49-43-18  
Волгоград (844)278-03-48  
Вологда (8172)26-41-59  
Воронеж (473)204-51-73  
Екатеринбург (343)384-55-89

Иваново (4932)77-34-06  
Ижевск (3412)26-03-58  
Иркутск (395)279-98-46  
Казань (843)206-01-48  
Калининград (4012)72-03-81  
Калуга (4842)92-23-67  
Кемерово (3842)65-04-62  
Киров (8332)68-02-04  
Коломна (4966)23-41-49  
Кострома (4942)77-07-48  
Краснодар (861)203-40-90  
Красноярск (391)204-63-61  
Курск (4712)77-13-04  
Курган (3522)50-90-47  
Липецк (4742)52-20-81

Магнитогорск (3519)55-03-13  
Москва (495)268-04-70  
Мурманск (8152)59-64-93  
Набережные Челны (8552)20-53-41  
Нижний Новгород (831)429-08-12  
Новокузнецк (3843)20-46-81  
Ноябрьск (3496)41-32-12  
Новосибирск (383)227-86-73  
Омск (3812)21-46-40  
Орел (4862)44-53-42  
Оренбург (3532)37-68-04  
Пенза (8412)22-31-16  
Петрозаводск (8142)55-98-37  
Псков (8112)59-10-37  
Пермь (342)205-81-47

Ростов-на-Дону (863)308-18-15  
Рязань (4912)46-61-64  
Самара (846)206-03-16  
Санкт-Петербург (812)309-46-40  
Саратов (845)249-38-78  
Севастополь (8692)22-31-93  
Саранск (8342)22-96-24  
Симферополь (3652)67-13-56  
Смоленск (4812)29-41-54  
Сочи (862)225-72-31  
Ставрополь (8652)20-65-13  
Сургут (3462)77-98-35  
Сыктывкар (8212)25-95-17  
Тамбов (4752)50-40-97  
Тверь (4822)63-31-35

Тольятти (8482)63-91-07  
Томск (3822)98-41-53  
Тула (4872)33-79-87  
Тюмень (3452)66-21-18  
Ульяновск (8422)24-23-59  
Улан-Удэ (3012)59-97-51  
Уфа (347)229-48-12  
Хабаровск (4212)92-98-04  
Чебоксары (8352)28-53-07  
Челябинск (351)202-03-61  
Череповец (8202)49-02-64  
Чита (3022)38-34-83  
Якутск (4112)23-90-97  
Ярославль (4852)69-52-93

Россия +7(495)268-04-70

Казахстан +7(7172)727-132

Киргизия +996(312)96-26-47

почта: [pad@nt-rt.ru](mailto:pad@nt-rt.ru) || сайт: <https://pestan.nt-rt.ru/>

# WE ARE

a private company Peštan, leader in the Balkans in the production and distribution of products and solutions from the polymers.

Company was founded in 1989 and has been producing water pipes made of polyethylene. Over time, we introduced new materials (polypropylene and PVC) and expanded product range. Today, in our offer you may find more than 8.500 products, divided into two categories:

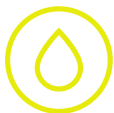

**PIPING  
SOLUTIONS**



**BATHROOM  
SOLUTIONS**

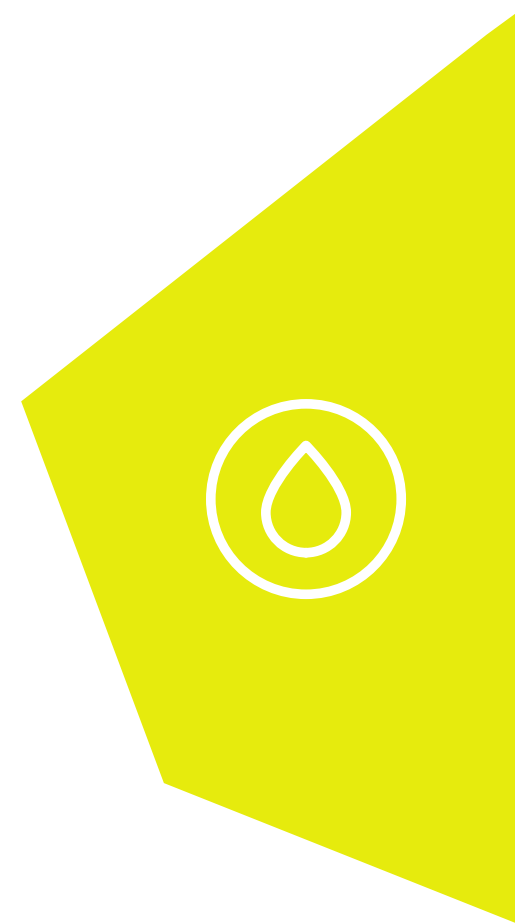

July 2024

---

Production facilities of company Peštan are located in Arandjelovac, Serbia. Annual revenue exceeding 170 million €, which is realized with the help of 1.200 employees. Peštan has a direct presence, through its daughter companies, in Bosnia and Herzegovina, as well as in Romania and through its representative offices in Albania, Croatia, Russia and the United Arab Emirates. Peštan operates in more than 80 countries worldwide through a global network of agents and distributors. Primarily export-oriented, the company is present in the market of Europe, Russia, Middle East, North Africa, Latin America and USA. The entire production is adjusted to European standards which is proved by international certificates for quality products:

DVGW, MPA, KIWA, SKZ, INSTA CERT, ITC, SPSC, IGH, VUPS, EMI, ICC, IAPMO, MIRTEC, and certificates of quality process ISO 9001, ISO 14001, ISO 45001, ISO 27001 and ISO 50001. For maximum satisfaction of customer needs, the company is constantly innovating and improving personnel and equipment. Since 2009, the company introduced the SAP ERP modules MM, SD, PP, FI CO, and since 2012 have extended functionality and WMS was included. The introduction of WCM and WMS system has increased the efficiency, contributed to the allocation of costs and professional maintenance. Central warehouse is located in Serbia, Arandjelovac, which is sized and designed to meet the requirements of the most demanding customers who want

efficient and reliable delivery of products. To respond to these requirements, Peštan has 15.000 m<sup>2</sup> of closed storage space for finished and semi-finished products, 10.000 m<sup>2</sup> warehouse for raw materials and intermediate goods, and approximately 120.000 m<sup>2</sup> of open storage space. Indoor storage space is equipped with shelves with over 21.000 pallet positions. Our vision is to be recognized as a leader in the Balkans, which provides customers with diversified solutions and products in one place. Our mission is creating a competitive advantage in our customers' businesses with the help of first-class solutions, services and products. We provide our company's success by consistently meeting the needs of clients, stakeholders and employees.



## KEY FACTS

**80**

AND MORE  
COUNTRIES  
WHERE WE EXPORT  
OUR PRODUCTS

**8.500**

DIFFERENT PRODUCTS  
IN OUR PRODUCTION  
ASSORTMENT

**65.000**

TONS OF MATERIAL  
PROCESSED  
ANNUALLY

# TYPES OF PIPING SOLUTIONS

**WATER  
AND HEATING**

**SEWAGE**

**DRAINAGE**

**CABLE  
PROTECTION**





# WATER & HEATING





# FLUIDTHERM

---



PP-R pipes & fittings for warm and cold water supply

PP-R and PP-RCT pipes are intended to be used for installation of hot and cold hygienic portable water, for heating and cooling systems, radiator connections, as well as for gray and reclaimed water transportation.

They are also intended to be used for the transportation of alimentary liquids, irrigation of the greenhouses and gardens, shipment of pressure air, vacuum installations, for the flow of various fluids in chemical industry, as well as for the transportation of the sea water and highly abrasive fluids. Their low weight and high tolerance to vibrations makes them suitable for various applications related to trains, ships, trucks and camping trailers, both in aggressive environment and on unstable ground.

## SPECIFICATION OF MATERIAL

---

### Polypropylene random copolymer [PP-R]

### Polypropylene random copolymer with modified crystallinity [PP-RCT]

Polypropylene Random Copolymer has been used in the domestic plumbing and mechanical applications for more than 20 years. With its long history and proven performance PP-R material made an excellent fit to the demand for pressure resistance at high temperatures. Increase of the ecological awareness contributed to the final recognition of our product as the superior one in

the world of liquid engineering. New generation of material named as PP-RCT is Polypropylene-Random-Copolymer with improved temperature resistance and enhanced crystalline structure brought about by a special nucleation. Proof of excellent performance characteristics of PP-RCT is categorized required strength (CRS) of 5 MPa at 70 °C and 50 years in comparison to a value of

3,21 MPa for standard PP-R. Offering more than 50% improved long-term strength PP-RCT enables designers to achieve higher pipe hydraulic capacity and gives them possibility to apply higher pressure than with standard PP-R with MRS 10.0 MPa. Quality of raw material is being controlled by the Health and Care State Institute.

## ADVANTAGES OF MATERIAL

---

### **Welding properties**

During the welding material suffers neither changes nor burnings thus connections between pipes and fittings are both strong and safe.

### **Burning cautery**

PP-R and PP-RCT is classified as normal flammable material which under ideal burning conditions turns into carbon monoxide and water.

\* For more informations regarding the applications for transportation of special fluids, operation conditions please contact Pestan's technical support.

### **Polymer is protected during processing**

Material can be processed several times without changes in molecular structure and without deterioration of physical and chemical characteristics and thermo-mechanical properties.

### **Impact strength**

Impact strength of PP-R and PP-RCT pipes significantly decreases at temperatures below 5 °C which is common for polypropylene pipes

### **Resistance to chemical substances and metals**

PP-R and PP-RCT is completely resistant to hydrolysis. Due to non- polar PP-R and PP-RCT behavior and specially designed additive package PP-R and PP-RCT are also suitable for transportation of the most of the chemicals.

### **Opacity**

Light transmission through PP-R and PP-RCT is less than 0.2% which prevents growth of algae on the inside surface of pipes and fittings meant for drinking water.



# PERMISSIBLE OPERATING PRESSURE DEPENDING ON TEMPERATURE AND THE EXPECTED LIFE OF THE TUBE IN ACCORDANCE WITH DIN 8077

PP-RCT

TEMPERATURE °C	SERVICE LIFE, YEARS	PERMISSIBLE OPERATING PRESSURE, BAR (SF=1,5)				
		S				
		5	4	3,2	2,5	
		SDR				
		11	9	7,4	6	
10	1	19,0	24,0	30,2	38,0	
	5	18,4	23,3	29,3	36,8	
	10	18,3	22,9	28,9	36,4	
	25	17,9	22,6	28,4	35,8	
	50	17,7	22,3	28,0	35,3	
	100	17,4	21,9	27,7	34,8	
20	1	16,6	20,8	26,3	33,1	
	5	16,1	20,2	25,4	32,1	
	10	15,8	19,9	25,1	31,6	
	25	15,5	19,6	24,7	31,0	
	50	15,3	19,3	24,3	30,6	
	100	15,1	19,0	24,0	30,2	
30	1	14,3	18,1	22,8	28,7	
	5	13,8	17,4	22,0	27,7	
	10	13,7	17,2	21,7	27,3	
	25	13,4	16,8	21,3	26,8	
	50	13,2	16,6	20,9	26,3	
	100	13,0	16,4	20,7	26,0	
40	1	12,3	15,5	19,6	24,7	
	5	11,9	15,0	18,8	23,8	
	10	11,8	14,8	18,6	23,4	
	25	11,5	14,4	18,2	22,9	
	50	11,3	14,3	17,9	22,6	
	100	11,1	14,0	17,7	22,3	
50	1	10,5	13,3	16,8	21,1	
	5	10,2	12,8	16,1	20,3	
	10	10,0	12,6	15,8	19,9	
	25	9,8	12,3	15,5	19,5	
	50	9,6	12,1	15,3	19,2	
	100	9,4	11,9	15,0	18,8	
60	1	8,9	11,3	14,2	17,8	
	5	8,6	10,8	13,6	17,2	
	10	8,4	10,6	13,3	16,8	
	25	8,3	10,3	13,1	16,5	
	50	8,1	10,2	12,8	16,2	
	70	1	7,5	9,4	11,9	15,0
5		7,2	9,1	11,4	14,4	
10		7,1	8,9	11,3	14,1	
25		6,9	8,7	10,9	13,8	
50		6,8	8,5	10,8	13,5	
80		1	6,3	7,9	9,9	12,5
	5	6,0	7,5	9,5	12,0	
	10	5,8	7,4	9,3	11,8	
	25	5,8	7,2	9,1	11,4	
	95	1	4,7	5,9	7,4	9,3
		5	4,4	5,6	7,1	8,9
10		4,3	5,5	6,9	8,8	

PP-R

TEMPERATURE °C	SERVICE LIFE, YEARS	PERMISSIBLE OPERATING PRESSURE, BAR (SF=1,5)			
		S			
		5	3,2	2,5	
		SDR			
		11	7,4	6	
10	1	17,6	27,8	35,1	
	5	16,5	26,3	33,1	
	10	16,1	25,6	32,2	
	25	15,6	24,8	31,2	
	50	15,2	24,1	30,0	
	100	14,8	23,5	29,6	
20	1	15,0	23,8	29,9	
	5	14,1	22,3	28,1	
	10	13,7	21,8	27,3	
	25	13,3	21,0	26,4	
	50	12,8	20,4	25,8	
	100	12,5	19,9	25,1	
30	1	12,8	20,2	25,4	
	5	11,9	18,9	23,8	
	10	11,6	18,4	23,2	
	25	11,2	17,8	22,3	
	50	10,8	17,3	21,8	
	100	10,6	16,8	21,2	
40	1	10,8	17,2	21,6	
	5	10,1	16,0	20,2	
	10	9,8	15,6	19,6	
	25	9,4	15,0	18,8	
	50	9,2	14,5	18,3	
	100	8,9	14,1	17,8	
50	1	9,2	14,5	18,3	
	5	8,5	13,5	17,0	
	10	8,3	13,1	16,5	
	25	7,9	12,6	15,8	
	50	7,7	12,3	15,4	
	100	7,5	11,8	14,9	
60	1	7,7	12,3	15,4	
	5	7,2	11,3	14,3	
	10	6,9	11,0	13,8	
	25	6,7	10,6	13,3	
	50	6,4	10,3	12,9	
	70	1	6,5	10,3	12,9
5		6,0	9,5	12,0	
10		5,8	9,3	11,6	
25		5,0	8,0	10,1	
50		4,3	6,8	8,5	
80		1	5,4	8,6	10,8
	5	4,8	7,6	9,6	
	10	4,0	6,4	8,1	
	25	3,3	5,2	6,5	
	95	1	3,8	6,1	7,7
		5	2,6	4,1	5,2
10		2,2	3,4	4,3	

## CHARACTERISTICS AND TECHNICAL DATA

---

- Long durability, thanks to its resistance to environment, IT DOESN'T CORODE.
- Possibility of damage breaching caused by unpredictable currents
- Small pressure loss because of the smooth surface, which prevents sediments to get caught on the pipe wall, prevents turbulence and friction.
- They don't contain poisonous ingredients and are completely in accordance with standards of the flow for drinking water.
- Great thermal and sound insulator.
- Risk of condensation diminished to minimum, which is the characteristic of metal pipes.
- Energy savings.
- Al insertions implemented in fitting are made of MS bar guaranteed chemical composition, which provides waterproofness of the joints.
- Excellent availability for welding. All parts can be connected with welding tool or electric muff.
- Very light, even 9 times lighter than steel which facilitates transportation and handling.

**PP-R pipes are used with installations for hot and cold water and sanitary water. They can completely step in place of the zinc pipes for use of the potable water even in cases of high concentration of calcium. They are also used in outflow of the potable liquids, irrigation in gardens, delivery of pressured air, vacuum installations, chemical industry with flow of diverse liquids, also with conduct of sea water and highly abrasive liquids. It is frequently used with radiant heating also with floor heating and air conditioning. Their small weight and high tolerance to vibration are good for appliance in trains, ships, trucks, trailers, in aggressive environment and unstable grounds.**

### **Pipes with glass fibers**

Dilatation diminishing can be realized by using composite PP-R and PP-RCT pipes with glass

fibers. They are 3 layer pipes which middle layer has coextruded glass fibers. PESTAN recommends that glass fiber pipes be used for hot potable water and heating applications. Standard PP-R and PP-RCT fittings can be used for joining pipes with glass fibers by welding method.

### **Installation of PP-R and PP-RCT pipe systems**

Process of head-to-head welding of pipes and fittings is very quick and simple. Joint of pipe and fitting is safe and strong, ready for use after couple of minutes.

### **Drinking water belongs to the best controlled foodstuffs**

Home pipe system for supplying sanitary water should not affect the quality of drinking water. The choice of sanitary pipe system and the quality of materials, which is used for their production, it is

therefore of crucial importance. The system of pipes for drinking water of PP-R and PP-RCT is due to its physico-chemical feature environmental friendly and hygienic. The technical suitability of PP-R and PP-RCT is proven around the world for more than 20 years.

### **Pipe insulation**

Pipe insulation is done to prevent dew and heat loss. PP-R pipes have a relatively low coefficient of thermal conductivity (0.24 W/mK), much lower than steel pipe, which allows significant energy savings. According to coefficient thermal conductivity, minimum insulation thickness is prescribed. When transporting cold liquids condensation may be possible ("sweating tube"), and is therefore desirable to insulate the pipe. Dew happens because of the differences between temperatures of transported fluid and ambient temperature.



**Pipes made by Peštan are easy to handle. They weigh up to 80% less than other metal pipes making them easy to position, unpack, ship or assemble.**

## INSTALLER BENEFITS

---

### **Air testing convenient**

With their remarkable characteristics, pipes made by Peštan successfully undergo the pressure test. Beside air pressure, the system can be tested using water air or water mix. Being very convenient, PEŠTAN pipes save time and prevent possible mess in case of a leak during the test.

### **Long-lasting material**

PP-R and PP-RCT is both chemically and physically durable material which proves to be unbreakable in cases of incidental damage.

### **Compatible piping system**

Due to the great compatibility of pipes made by Peštan which provides a wide range of edge connections and most advanced PP-R and PP-RCT, connecting systems and equipment are easily and quickly installed on safe way.

### **Time-saving fusion**

Pipes and fittings made by Peštan are assembled with heat fusion and, as mentioned earlier, heat fusion is a process used to join pipes and fittings together by heating the materials and inserting them together which results in a perfect bond every time. It can save up to 50% of labor time compared to traditional welding and soldering.

### **Inflexible hanging pipe**

Inflexible and rigid on their hangers, pipes made by Peštan appear to be clean and conventional with elbows and tees. That is why an installer can assemble more pipes while the final product is left to a craftsman.

### **Consistent outcomes**

Using of PP-R and PP-RCT and heat fusion resulted in consistency and reliability of the piping system. The whole system can work without a single leak anywhere.

### **Expansion control**

There is no need for additional expansion control since linear expansion is reduced by the fiber layer. The pipe itself absorbs its own stresses when fixed or buried so the expansion loops can be in use for longer period of time.

### **Flexible bonds and extent**

Heat fusion bonds share the same properties with the pipes and fittings. This means that an assembled pipe is flexible enough to be prefabricated and moved without risking joints to crack or leak. Such an advantage also contributes to pipe protection from seismic activity but also gives the pipes even wider field of application.

## TRANSPORT AND STORAGE

**When storing PP-R pipes, make sure that they are separate from areas where solvents, adhesives, paint and similar products.**

If the area where the tube occupied by moderate heating to 50 °C, it is necessary that the distance between the tube and the heating body, of at least 1 m. Storage should be chosen so that the pipe is always placed against it over the entire surface. One should avoid bending in storage and in transit. During transport pipes are not allowed to lay on the flat, truck or deck. Also, the pipes must be protected from mechanical damage and provided in a way that they are not exposed to dirt, solvents or direct heat.

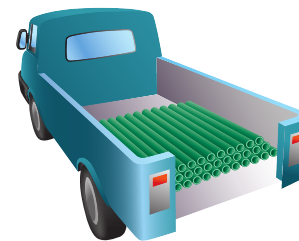
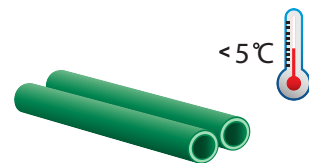

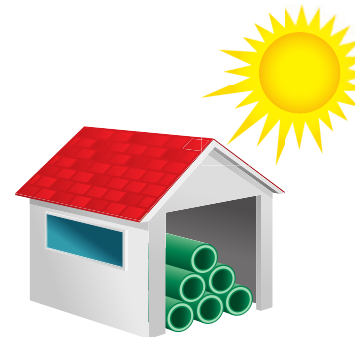
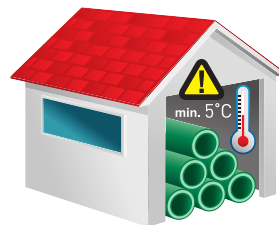

- Fluidtherm tubes can be stored at a temperature of at least 50 °C.
- PP-R pipes should be protected from direct UV radiation
- Storage PP-R pipe
- Pipes at low temperatures become fragile
- Right and wrong transporting PP-R pipe



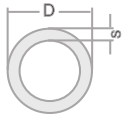





ITEM DESCRIPTION	PICTURE	SDR	CODE	OD, MM	S, MM	DINN, MM
FLUIDTHERM PPR PIPE (PP-R)			GREEN      WHITE      GRAY			
		<b>EN 15874</b>				
			10000220	16	2,7	10,6
			10000230	20	3,4	13,2
			10000240	25	4,2	16,6
			10000250	32	5,4	21,2
			10000260	40	6,7	26,6
		SDR 6 [PN25]	10000270	50	8,3	33,4
			10000280	63	10,5	42
			10000290	75	12,5	50
			10000300	90	15	60
			10000310	110	18,3	73,4
			10000315	125	20,8	83,4
				160	26,6	106,8
		<b>DIN 8077</b>				
		SDR 6 [PN25]		200	33,2	133,6
		<b>EN 15874</b>				
			10000120	16	2,2	11,6
			10000130	20	2,8	14,4
			10000140	25	3,5	18
			10000150	32	4,4	23,2
			10000160	40	5,5	29
		SDR 7.4 [PN20]	10000170	50	6,9	36,2
			10000180	63	8,6	45,8
			10000190	75	10,3	54,4
			10000200	90	12,3	65,4
			10000210	110	15,1	79,8
			10000215	125	17,1	90,8
				160	21,9	106,8
		<b>DIN 8077</b>				
		SDR 7.4 [PN20]		200	27,4	133,6
				250	34,2	181,6
		<b>DIN 8077</b>				
				200	22,4	155,2
				250	27,9	194,2
		SDR 9 [PN16]		315	35,2	244,6
				355	39,7	275,6
		<b>EN 15874</b>				

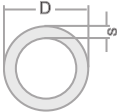



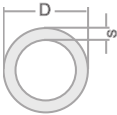

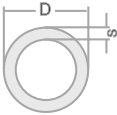
ITEM DESCRIPTION	PICTURE	SDR	CODE			OD, MM	S, MM	DINN, MM		
			GREEN	WHITE	GRAY					
FLUIDTHERM PPR PIPE (PP-R)		SDR 11 [PN10]				16	1,8	12,4		
						20	1,9	16,2		
						25	2,3	20,4		
						32	2,9	26,2		
						40	3,7	32,6		
						50	4,6	40,8		
						63	5,8	51,4		
						75	6,8	61,4		
						90	8,2	73,6		
						110	10	90		
						125	11,4	102,2		
						160	14,6	126,8		
					<b>DIN 8077</b>					
								200	18,2	163,6
								250	22,7	204,6
				SDR 11 [PN12,5]			315	28,6	257,8	
							355	32,2	290,6	
							400	36,3	327,4	
				<b>DIN 8077</b>						
		SDR 17,6 [PN6]								
FLUIDTHERM PPR PIPE (PP-R / PP-R FG / PP-R)		<b>EN 15874</b>								
				SDR 6 [PN 25]						

ITEM DESCRIPTION	PICTURE	SDR	CODE	OD, MM	S, MM	DINN, MM
FLUIDTHERM PPR PIPE (PP-R / PP-R FG / PP-R)			GREEN WHITE GRAY			
	 	<b>EN 15874</b>		125	20.8	83.4
		SDR 6 [PN25]		160	26.6	106.8
		<b>DIN 8077</b>		200	33.2	133.6
		SDR 6 [PN 25]				
		<b>EN 15874</b>		16	2.2	11.6
				20	2.8	14.4
				25	3.5	18
				32	4.4	23.2
				40	5.5	29
		SDR 7.4 [PN 20]		50	6.9	36.2
				63	8.6	45.8
				75	10.3	54.4
				90	12.3	65.4
				110	15.1	79.8
				125	17.1	90.8
				160	21.9	116.2
		<b>DIN 8077</b>		200	27.4	133.6
		SDR 7.4 [PN 20]		250	34.2	181.6
		<b>DIN 8077</b>		200	22.4	155.2
				250	27.9	194.2
		SDR 9 [PN 16]		315	35.2	244.6
				355	39.7	275.6

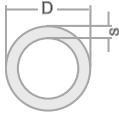
ITEM DESCRIPTION	PICTURE	SDR	CODE			OD, MM	S, MM	DINN, MM		
FLUIDTHERM PPR PIPE (PP-R / PP-R FG / PP-R)			GREEN	WHITE	GRAY					
 		<b>EN 15874</b>				16	1.8	12.4		
							20	1.9	16.2	
							25	2.3	20.4	
							32	2.9	26.2	
							40	3.7	32.6	
							50	4.6	40.8	
		SDR 11 [PN 10]					63	5.8	51.4	
							75	6.8	61.4	
							90	8.2	73.6	
							110	10	90	
							125	11.4	102.2	
							160	14.6	126.8	
				<b>DIN 8077</b>						
								200	18.2	163.6
								250	22.7	204.6
		SDR 11 [PN 12,5]						315	28.6	257.8
								355	32.2	290.6
								400	36.3	327.4
				<b>DIN 8077</b>						
								200	11.4	177.2
						250	14.2	221.2		
						315	17.9	279.2		
SDR 17.6 [PN 6]						355	20.1	314.8		
						400	22.7	354.6		
						500	28.4	443.2		
						630	35.7	558.6		
<b>FLUIDTHERM PPR PIPE (PP-R / PP-R FG / PP-R)</b>			<b>GREEN</b>	<b>WHITE</b>	<b>GRAY</b>					
 		<b>EN 15874</b>								
		SDR 6 [PN 25]								

ITEM DESCRIPTION	PICTURE	SDR	CODE	OD, MM	S, MM	DINN, MM	
FLUIDTHERM PPR PIPE (PP-R / PP-R FG / PP-R)			GREEN WHITE GRAY				
 	<b>EN 15874</b>			125	20.8	83.4	
				160	26.6	106.8	
	SDR 6 [PN25]						
	<b>DIN 8077</b>						
					200	33.2	133.6
	SDR 6 [PN 25]						
	<b>EN 15874</b>						
					16	2.2	10.6
					20	2.8	13.2
					25	3.5	16.6
					32	4.4	21.2
					40	5.5	26.6
					50	6.9	33.4
	SDR 7,4 [PN 20]				63	8.6	42
					75	10.3	50
					90	12.3	60
					110	15.1	73.4
					125	17.1	83.4
				160	21.9	106.8	
<b>DIN 8077</b>							
				200	27.4	133.6	
SDR 7.4 [PN20]				250	34.2	181.6	
<b>DIN 8077</b>							
				200	22.4	155.2	
				250	27.9	194.2	
SDR 7.4 [PN20]				315	35.2	244.6	
				355	39.7	275.6	



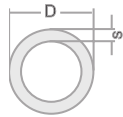

ITEM DESCRIPTION	PICTURE	SDR	CODE			OD, MM	S, MM	DINN, MM
FLUIDTHERM PPR PIPE (PP-R / PP-R FG / PP-R)			GREEN	WHITE	GRAY			
		<b>EN 15874</b>						
						16	1.8	12.4
						20	1.9	16.2
						25	2.3	20.4
						32	2.9	26.2
						40	3.7	32.6
						50	4.6	40.8
		SDR 11 [PN 10]				63	5.8	51.4
						75	6.8	61.4
						90	8.2	73.6
						110	10	90
						125	11.4	102.2
						160	14.6	126.8
		<b>DIN 8077</b>						
						200	18.2	163.6
						250	22.7	204.6
		SDR 11 [PN 12,5]				315	28.6	257.8
						355	32.2	290.6
						400	36.3	327.4
		<b>DIN 8077</b>						
						200	11.4	177.2
						250	14.2	221.2
						315	17.9	279.2
		SDR 17,6 [PN 6]				355	20.1	314.8
						400	22.7	354.6
						500	28.4	443.2
						630	35.7	558.6

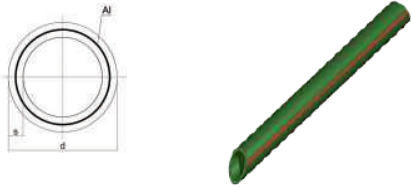

ITEM DESCRIPTION	PICTURE	SDR	CODE			OD, MM	S, MM	DINN, MM
FLUIDTHERM PPR PIPE (PP-R/AL/PP-R)			GREEN	WHITE	GRAY			
		<b>EN 15874</b>						
						20	2.8	14.4
						25	4.2	16.6
						32	5.4	21.2
		SDR 6 PN [20]				40	6.7	26.6
						50	8.3	33.4
						63	10.5	42
		<b>EN 15874</b>						
						25	3.5	18
						32	4.4	23.2
		SDR 7,4 [PN16]				40	5.5	29
						50	6.9	36.2
						63	8.6	45.8
		<b>EN 15874</b>						
						20	1.9	16.2
						25	2.3	20.4
		SDR 11 [PN10]				32	2.9	26.2
						40	3.7	32.6
						50	4.6	40.8
						63	5.8	51.4

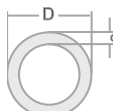

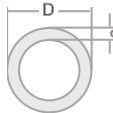
ITEM DESCRIPTION	PICTURE	SDR	CODE			OD, MM	S, MM	DINN, MM	
			GREEN	WHITE	GRAY				
FLUIDTHERM PPR PIPE (PP - RCT)		<b>EN 15874</b>							
						20	3.4	13.2	
						25	4.2	16.6	
						32	5.4	21.2	
						40	6.7	26.6	
						50	8.3	33.4	
						63	10.5	42	
				SDR 6 [PN 25]			75	12.5	50
							90	15	60
							110	18.3	73.4
							125	20.8	83.4
							160	26.6	106.8
				<b>DIN 8077</b>					
				SDR 6 [PN 25]			200	33.2	133.6
				<b>EN 15874</b>					
							20	2.8	13.2
							25	3.5	16.6
							32	4.4	21.2
							40	5.5	26.6
							50	6.9	33.4
							63	8.6	42
				SDR 7,4 [PN 20]			75	10.3	50
							90	12.3	60
							110	15.1	73.4
							125	17.1	83.4
							160	21.9	106.8
				<b>DIN 8077</b>					
				SDR 7,4 [PN 20]			200	27.4	133.6
					250	34.2	181.6		
		<b>EN 15874</b>							
					20	2.3	15.4		
					25	2.8	19.4		
					32	3.6	24.8		
					40	4.4	31.2		
					50	5.6	38.8		
					63	7.1	48.8		
		SDR 9 [PN 16]			75	8.4	58.2		
					90	10.1	69.8		
					110	12.3	85.4		
					125	14	97		
					160	17.9	124.2		
		<b>DIN 8077</b>							
		SDR 9 [PN 16]			200	22.4	155.2		
					250	27.9	194.2		
					315	35.2	244.6		
					355	39.7	275.6		

ITEM DESCRIPTION	PICTURE	SDR	GREEN	WHITE	GRAY	OD, MM	S, MM	DINN, MM	
<b>FLUIDTHERM PPR PIPE (PP - RCT)</b>									
 	<b>EN 15874</b>					20	1.9	16.2	
						25	2.3	20.4	
						32	2.9	26.2	
						40	3.7	32.6	
						50	4.6	40.8	
	SDR 11 [PN 10]					63	5.8	51.4	
						75	6.8	61.4	
						90	8.2	73.6	
						110	10	90	
						125	11.4	102.2	
						160	14.6	126.8	
	<b>DIN 8077</b>								
							200	18.2	163.6
							250	22.7	204.6
	SDR 11 [PN 12,5]						315	28.6	257.8
							355	32.2	290.6
							400	36.3	327.4
	<b>DIN 8077</b>								
							200	11.4	163.6
							250	14.2	204.6
						315	17.9	257.8	
SDR 17,6 [PN 8]						355	20.1	290.6	
						400	22.7	327.4	
						500	28.4	443.2	
						630	35.7	558.6	
<b>FLUIDTHERM PPR PIPE (PP - RCT / PP - RCT - FG / PP - RCT)</b>									
 	<b>EN 15874</b>					20	3.4	13.2	
						25	4.2	16.6	
						32	5.4	21.2	
						40	6.7	26.6	
						50	8.3	33.4	
	SDR 6 [PN 25]					63	10.5	42	
						75	12.5	50	
						90	15	60	
						110	18.3	73.4	
						125	20.8	83.4	
						160	26.6	106.8	

ITEM DESCRIPTION	PICTURE	SDR	CODE			OD, MM	S, MM	DINN, MM	
			GREEN	WHITE	GRAY				
FLUIDTHERM PPR PIPE (PP-RCT / PP-RCT-FG / PP-RCT)		<b>DIN 8077</b>							
		SDR 6 [PN 25]				200	33.2	133.6	
		<b>EN 15874</b>							
							20	2.8	13.2
							25	3.5	16.6
							32	4.4	21.2
							40	5.5	26.6
							50	6.9	33.4
		SDR 7,4 [PN 20]					63	8.6	42
							75	10.3	50
							90	12.3	60
							110	15.1	73.4
							125	17.1	83.4
							160	21.9	106.8
		<b>DIN 8077</b>							
		SDR 7,4 [PN 20]					200	27.4	133.6
							250	34.2	181.6
		<b>EN 15874</b>							
							20	2.3	15.4
							25	2.8	19.4
							32	3.6	24.8
							40	4.4	31.2
							50	5.6	38.8
		SDR 9 [PN 16]					63	7.1	48.8
							75	8.4	58.2
							90	10.1	69.8
							110	12.3	85.4
							125	14	97
					160	17.9	124.2		
<b>DIN 8077</b>									
SDR 9 [PN 16]					200	22.4	155.2		
					250	27.9	194.2		
					315	35.2	244.6		
					355	39.7	275.6		

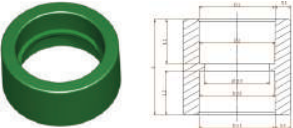

ITEM DESCRIPTION	PICTURE	SDR	CODE	OD, MM	S, MM	DINN, MM	
FLUIDTHERM PPR PIPE (PP - RCT / PP - RCT - FG / PP - RCT)			GREEN WHITE GRAY				
		<b>EN 15874</b>		20	1.9	16.2	
				25	2.3	20.4	
				32	2.9	26.2	
				40	3.7	32.6	
				50	4.6	40.8	
SDR 11 [PN 10]				63	5.8	51.4	
				75	6.8	61.4	
				90	8.2	73.6	
				110	10	90	
				125	11.4	102.2	
				160	14.6	126.8	
			<b>DIN 8077</b>		200	18.2	163.6
					250	22.7	204.6
SDR 11 [PN 12,5]					315	28.6	257.8
					355	32.2	290.6
					400	36.3	327.4
			<b>DIN 8077</b>		200	11.4	163.6
					250	14.2	204.6
					315	17.9	257.8
SDR 17,6 [PN 8]					355	20.1	290.6
				400	22.7	327.4	
				500	28.4	443.2	
				630	35.7	558.6	

ITEM DESCRIPTION	PICTURE	CODE			DN		e	D <sub>1</sub>	D <sub>2</sub>	D <sub>3</sub> - D <sub>33</sub>	L <sub>1</sub>	L <sub>2</sub>	Weight
		GREEN	WHITE	GRAY	[inc]	[mm]	[mm]	[mm]	[mm]	[mm]	[mm]	[mm]	[kg]
PPR SOCKET		10001600	10011600	10021600	3/8"	16	3.3	15.2 <sup>+0.3</sup>	15.1 <sup>+0.3</sup>	11.2	37	13.3	
		10001601	10011601	10021601	1/2"	20	4.1	19.2 <sup>+0.3</sup>	19.0 <sup>+0.3</sup>	15.2	36	14.5	0.009
		10001602	10011602	10021602	3/4"	25	5.1	24.2 <sup>+0.3</sup>	23.9 <sup>+0.4</sup>	19.4	40	16	0.016
		10001603	10011603	10021603	1"	32	6.5	31.1 <sup>+0.4</sup>	30.9 <sup>+0.4</sup>	25.0	41	18.1	0.029
		10001604	10011604	10021604	1 1/4"	40	8.1	39.0 <sup>+0.4</sup>	38.8 <sup>+0.4</sup>	31.4	48	20.5	0.057
		10001605	10011605	10021605	1 1/2"	50	10.1	48.9 <sup>+0.5</sup>	48.7 <sup>+0.5</sup>	39.4	56	23.5	0.087
		10001606	10011606	10021606	2"	63	12.7	61.9 <sup>+0.6</sup>	61.6 <sup>+0.5</sup>	49.8	63	27.4	0.168
		10001607	10011607	10021607	2 1/2"	75	15.1	74.3 <sup>+0.6</sup>	73.1 <sup>+0.6</sup>	59.4	67	31	0.201
		10001608	10011608	10021608	3"	90	18.1	89.3 <sup>+0.6</sup>	87.9 <sup>+0.6</sup>	71.6	75	35.5	0.325
		10001609	10011609	10021609	4"	110	22.1	109.4 <sup>+0.6</sup>	107.7 <sup>+0.6</sup>	87.6	88	41.5	0.610
		10001210			4 1/2"	125	25.1	124.6 <sup>+0.4</sup>	123.0 <sup>+2.0</sup>	99.7	100	46.5	0.880

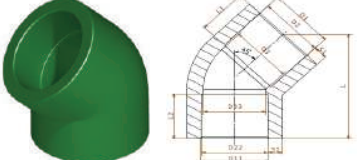
ITEM DESCRIPTION	PICTURE	CODE			DN		e	D <sub>1</sub>	D <sub>2</sub>	D <sub>3</sub> - D <sub>33</sub>	L <sub>1</sub>	L <sub>2</sub>	Weight
		GREEN	WHITE	GRAY	[inc]	[mm]	[mm]	[mm]	[mm]	[mm]	[mm]	[mm]	[kg]
ELBOW 45°		10001000	10011000	10021000	1/2"	20	4.1	19.2 <sup>+0.3</sup>	19.0 <sup>+0.3</sup>	15.2	35.2	14.5	0.012
		10001001	10011001	10021001	3/4"	25	5.1	24.2 <sup>+0.3</sup>	23.9 <sup>+0.4</sup>	19.4	39.5	16	0.020
		10001002	10011002	10021002	1"	32	6.5	31.1 <sup>+0.4</sup>	30.9 <sup>+0.4</sup>	25.0	46.5	18.1	0.037
		10001003	10011003	10021003	1 1/4"	40	8.1	39.0 <sup>+0.4</sup>	38.8 <sup>+0.4</sup>	31.4	54	20.5	0.079
		10001004	10011004	10021004	1 1/2"	50	10.1	48.9 <sup>+0.5</sup>	48.7 <sup>+0.5</sup>	39.4	62.4	23.5	0.116
		10001005	10011005	10021005	2"	63	12.7	61.9 <sup>+0.6</sup>	61.6 <sup>+0.5</sup>	49.8	71.4	27.4	0.206
		10001006	10011006	10021006	2 1/2"	75	15.1	74.3 <sup>+0.6</sup>	73.1 <sup>+0.6</sup>	59.4	81.4	30	0.336
		10001007	10011007	10021007	3"	90	18.1	89.3 <sup>+0.6</sup>	87.9 <sup>+0.6</sup>	71.6	92.5	33	0.554
		10001009			4 1/2"	125	25.0	123.9 <sup>+1.2</sup>	124.6 <sup>+0.4</sup>	99.7	127	40	1.386

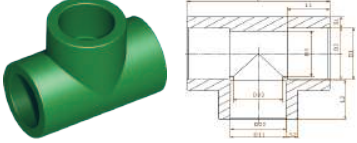
ITEM DESCRIPTION	PICTURE	CODE			DN		e	D <sub>1</sub>	D <sub>2</sub>	D <sub>3</sub> - D <sub>33</sub>	L <sub>1</sub>	L <sub>2</sub>	Weight
		GREEN	WHITE	GRAY	[inc]	[mm]	[mm]	[mm]	[mm]	[mm]	[mm]	[mm]	[kg]
TEE		10001900	10011900	10021900	1/2"	20	4.1	19.2 <sup>+0.3</sup>	19.0 <sup>+0.3</sup>	15.2	54	14.5	0.019
		10001901	10011901	10021901	3/4"	25	5.1	24.2 <sup>+0.3</sup>	23.9 <sup>+0.4</sup>	19.4	62	16	0.031
		10001902	10011902	10021902	1"	32	6.5	31.1 <sup>+0.4</sup>	30.9 <sup>+0.4</sup>	25.0	75	18.1	0.066
		10001903	10011903	10021903	1 1/4"	40	8.1	39.0 <sup>+0.4</sup>	38.8 <sup>+0.4</sup>	31.4	86	20.5	0.111
		10001904	10011904	10021904	1 1/2"	50	10.1	48.9 <sup>+0.5</sup>	48.7 <sup>+0.5</sup>	39.4	100	23.5	0.188
		10001905	10011905	10021905	2"	63	12.7	61.9 <sup>+0.6</sup>	61.6 <sup>+0.5</sup>	49.8	126	27.4	0.324
		10001906	10011906	10021906	2 1/2"	75	15.1	74.3 <sup>+0.6</sup>	73.1 <sup>+0.6</sup>	59.4	138	31	0.540
		10001907	10011907	10021907	3"	90	18.1	89.3 <sup>+0.6</sup>	87.9 <sup>+0.6</sup>	71.6	162	35.5	0.905
		10001908	10011908	10021908	4"	110	22.1	109.4 <sup>+0.6</sup>	107.7 <sup>+0.6</sup>	87.6	196	41.5	2.283
		10001810			4 1/2"	125	25.0	123.9 <sup>+1.2</sup>	123.5 <sup>+1.2</sup>	99.7	208	46.5	

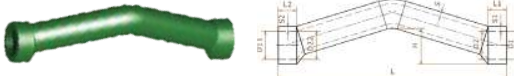
ITEM DESCRIPTION	PICTURE	CODE			DN		S	S <sub>1</sub> - S <sub>2</sub>	D <sub>1</sub> - D <sub>11</sub>	D <sub>2</sub> - D <sub>22</sub>	L	L <sub>1</sub> - L <sub>2</sub>	H	Weight
		GREEN	WHITE	GRAY	[inc]	[mm]	[mm]	[mm]	[mm]	[mm]	[mm]	[mm]	[mm]	[kg]
BRIDGE (MOULDING)		10003050	10013050	10023050	1/2"	20	3.4 <sup>+0.5</sup>	4.1	19.2 <sup>+0.3</sup>	19.0 <sup>+0.3</sup>	158	14.5	24	0.033
		10003051	10013051	10023051	3/4"	25	4.2 <sup>+0.6</sup>	5.1	24.2 <sup>+0.3</sup>	23.9 <sup>+0.4</sup>	199	16	33	0.055
		10003052	10013052	10023052	1"	32	5.4 <sup>+0.7</sup>	6.5	31.1 <sup>+0.4</sup>	30.9 <sup>+0.4</sup>	250	18.1	40	0.112

ITEM DESCRIPTION	PICTURE	CODE			DN		S <sub>1</sub>	S <sub>2</sub>	D <sub>1</sub>	D <sub>2</sub>	D <sub>3</sub>	D <sub>11</sub>	D <sub>22</sub>	D <sub>33</sub>	L	L <sub>1</sub>	L <sub>2</sub>	Weight
		GREEN	WHITE	GRAY	[inc]	[mm]	[mm]	[mm]	[mm]	[mm]	[mm]	[mm]	[mm]	[mm]	[mm]	[mm]	[mm]	[mm]
TEE REDUCED		10002000	10012000	10022000	1/2" x 1/2" x 3/4"	20 x 20 x 25	4.1	5.1	19.2 <sup>+0.3</sup>	19.0 <sup>+0.3</sup>	15.2	24.2 <sup>+0.3</sup>	23.9 <sup>+0.4</sup>	19.4	63	14.5	16	0.027
		10002005	10012005	10022005	3/4" x 3/4" x 1/2"	25 x 25 x 20	5.1	4.1	24.2 <sup>+0.3</sup>	23.9 <sup>+0.4</sup>	19.4	19.2 <sup>+0.3</sup>	19.0 <sup>+0.3</sup>	15.2	63	16	14.5	0.040
		10002010	10012010	10022010	1" x 1" x 1/2"	32 x 32 x 20	6.5	4.1	31.1 <sup>+0.4</sup>	30.9 <sup>+0.4</sup>	25.0	19.2 <sup>+0.3</sup>	19.0 <sup>+0.3</sup>	15.2	74	18.1	14.5	0.048
		10002011	10012011	10022011	1" x 1" x 3/4"	32 x 32 x 25	6.5	5.1	31.1 <sup>+0.4</sup>	30.9 <sup>+0.4</sup>	25.0	24.2 <sup>+0.3</sup>	23.9 <sup>+0.4</sup>	19.4	74	18.1	16	0.056
		10002020	10012020	10022020	1 1/4" x 1 1/4" x 1/2"	40 x 40 x 20	8.1	4.1	39.0 <sup>+0.4</sup>	38.8 <sup>+0.4</sup>	31.4	19.2 <sup>+0.3</sup>	19.0 <sup>+0.3</sup>	15.2	87	20.5	14.5	0.077
		10002021	10012021	10022021	1 1/4" x 1 1/4" x 3/4"	40 x 40 x 25	8.1	5.1	39.0 <sup>+0.4</sup>	38.8 <sup>+0.4</sup>	31.4	24.2 <sup>+0.3</sup>	23.9 <sup>+0.4</sup>	19.4	87	20.5	16	0.086
		10002022	10012022	10022022	1 1/4" x 1 1/4" x 1"	40 x 40 x 32	8.1	6.5	39.0 <sup>+0.4</sup>	38.8 <sup>+0.4</sup>	31.4	31.1 <sup>+0.4</sup>	30.9 <sup>+0.4</sup>	25.0	76	20.5	18.1	0.097
		10002030	10012030	10022030	1 1/2" x 1 1/2" x 1/2"	50 x 50 x 20	10.1	4.1	48.9 <sup>+0.5</sup>	48.7 <sup>+0.5</sup>	39.4	19.2 <sup>+0.3</sup>	19.0 <sup>+0.3</sup>	15.2	70	23.5	14.5	
		10002031	10012031	10022031	1 1/2" x 1 1/2" x 3/4"	50 x 50 x 25	10.1	5.1	48.9 <sup>+0.5</sup>	48.7 <sup>+0.5</sup>	39.4	24.2 <sup>+0.3</sup>	23.9 <sup>+0.4</sup>	19.4	74	23.5	16	0.119
		10002032	10012032	10022032	1 1/2" x 1 1/2" x 1"	50 x 50 x 32	10.1	6.5	48.9 <sup>+0.5</sup>	48.7 <sup>+0.5</sup>	39.4	31.1 <sup>+0.4</sup>	30.9 <sup>+0.4</sup>	25.0	82	23.5	18.1	0.134
		10002033	10012033	10022033	1 1/2" x 1 1/2" x 1 1/4"	50 x 50 x 40	10.1	8.1	48.9 <sup>+0.5</sup>	48.7 <sup>+0.5</sup>	39.4	39.0 <sup>+0.4</sup>	38.8 <sup>+0.4</sup>	31.4	90	23.5	20.5	0.153
		10002040	10012040	10022040	2" x 2" x 1/2"	63 x 63 x 20	12.7	4.1	61.9 <sup>+0.6</sup>	61.6 <sup>+0.5</sup>	49.8	19.2 <sup>+0.3</sup>	19.0 <sup>+0.3</sup>	15.2	78	27.4	14.5	
		10002041	10012041	10022041	2" x 2" x 3/4"	63 x 63 x 25	12.7	5.1	61.9 <sup>+0.6</sup>	61.6 <sup>+0.5</sup>	49.8	24.2 <sup>+0.3</sup>	23.9 <sup>+0.4</sup>	19.4	84	27.4	16	0.208
		10002042	10012042	10022042	2" x 2" x 1"	63 x 63 x 32	12.7	6.5	61.9 <sup>+0.6</sup>	61.6 <sup>+0.5</sup>	49.8	31.1 <sup>+0.4</sup>	30.9 <sup>+0.4</sup>	25.0	90	27.4	18.1	0.225
		10002043	10012043	10022043	2" x 2" x 1 1/4"	63 x 63 x 40	12.7	8.1	61.9 <sup>+0.6</sup>	61.6 <sup>+0.5</sup>	49.8	39.0 <sup>+0.4</sup>	38.8 <sup>+0.4</sup>	31.4	98	27.4	20.5	0.249
		10002044	10012044	10002044	2" x 2" x 1 1/2"	63 x 63 x 50	12.7	10.1	61.9 <sup>+0.6</sup>	61.6 <sup>+0.5</sup>	49.8	48.9 <sup>+0.5</sup>	48.7 <sup>+0.5</sup>	39.4	108	27.4	23.5	0.288
					2 1/2" x 2 1/2" x 1/2"	75 x 75 x 20	15.1	4.1	74.3 <sup>+0.6</sup>	73.1 <sup>+0.6</sup>	59.4	19.2 <sup>+0.3</sup>	19.0 <sup>+0.3</sup>	15.2	86	31	14.5	
		10002330			2 1/2" x 2 1/2" x 3/4"	75 x 75 x 25	15.1	5.1	74.3 <sup>+0.6</sup>	73.1 <sup>+0.6</sup>	59.4	24.2 <sup>+0.3</sup>	23.9 <sup>+0.4</sup>	19.4	90	31	16	0.320
		10002050	10012050	10022050	2 1/2" x 2 1/2" x 1"	75 x 75 x 32	15.1	6.5	74.3 <sup>+0.6</sup>	73.1 <sup>+0.6</sup>	59.4	31.1 <sup>+0.4</sup>	30.9 <sup>+0.4</sup>	25.0	96	31	18.1	0.342
		10002051	10012051	10022051	2 1/2" x 2 1/2" x 1 1/4"	75 x 75 x 40	15.1	8.1	74.3 <sup>+0.6</sup>	73.1 <sup>+0.6</sup>	59.4	39.0 <sup>+0.4</sup>	38.8 <sup>+0.4</sup>	31.4	104	31	20.5	0.374
		10002052			2 1/2" x 2 1/2" x 1 1/2"	75 x 75 x 50	15.1	10.1	74.3 <sup>+0.6</sup>	73.1 <sup>+0.6</sup>	59.4	48.9 <sup>+0.5</sup>	48.7 <sup>+0.5</sup>	39.4	112	31	23.5	0.412
		10002053		10022053	2 1/2" x 2 1/2" x 2"	75 x 75 x 63	15.1	12.7	74.3 <sup>+0.6</sup>	73.1 <sup>+0.6</sup>	59.4	61.9 <sup>+0.6</sup>	61.6 <sup>+0.5</sup>	49.8	125	31	27.4	0.478
					3" x 3" x 1"	90 x 90 x 32	18.1	6.5	89.3 <sup>+0.6</sup>	87.9 <sup>+0.6</sup>	71.6	31.1 <sup>+0.4</sup>	30.9 <sup>+0.4</sup>	25.0	104	35.5	18.1	0.534
		10002070	10012070	10022070	3" x 3" x 1 1/4"	90 x 90 x 40	18.1	8.1	89.3 <sup>+0.6</sup>	87.9 <sup>+0.6</sup>	71.6	39.0 <sup>+0.4</sup>	38.8 <sup>+0.4</sup>	31.4	110	35.5	20.5	0.566
			10012071	10022071	3" x 3" x 1 1/2"	90 x 90 x 50	18.1	10.1	89.3 <sup>+0.6</sup>	87.9 <sup>+0.6</sup>	71.6	48.9 <sup>+0.5</sup>	48.7 <sup>+0.5</sup>	39.4	120	35.5	23.5	0.626
			10002072		3" x 3" x 2"	90 x 90 x 63	18.1	12.7	89.3 <sup>+0.6</sup>	87.9 <sup>+0.6</sup>	71.6	61.9 <sup>+0.6</sup>	61.6 <sup>+0.5</sup>	49.8	132	35.5	27.4	0.656
			10012073		3" x 3" x 2 1/2"	90 x 90 x 75	18.1	15.1	89.3 <sup>+0.6</sup>	87.9 <sup>+0.6</sup>	71.6	74.3 <sup>+0.6</sup>	73.1 <sup>+0.6</sup>	59.4	144	35.5	31	0.792
		10002080	10012080	10022080	4" x 4" x 1 1/2"	110 x 110 x 50	22.1	10.1	109.4 <sup>+0.6</sup>	107.7 <sup>+0.6</sup>	87.6	48.9 <sup>+0.5</sup>	48.7 <sup>+0.5</sup>	39.4	150	41.5	23.5	
		10002081	10012081	10022081	4" x 4" x 2"	110 x 110 x 63	22.1	12.7	109.4 <sup>+0.6</sup>	107.7 <sup>+0.6</sup>	87.6	61.9 <sup>+0.6</sup>	61.6 <sup>+0.5</sup>	49.8		41.5	27.4	
		10002082			4" x 4" x 2 1/2"	110 x 110 x 75	22.1	15.1	109.4 <sup>+0.6</sup>	107.7 <sup>+0.6</sup>	87.6	74.3 <sup>+0.6</sup>	73.1 <sup>+0.6</sup>	59.4	155	41.5	31	1.623
		10002083			4" x 4" x 3"	110 x 110 x 90	22.1	18.1	109.4 <sup>+0.6</sup>	107.7 <sup>+0.6</sup>	87.6	89.3 <sup>+0.6</sup>	87.9 <sup>+0.6</sup>	71.6	165	41.5	35.5	1.762
					4 1/2" x 4 1/2" x 2 1/2"	125 x 125 x 75	25.1	15.1	123.9 <sup>+1.2</sup>	123.5 <sup>+1.2</sup>	99.7	74.3 <sup>+0.6</sup>	73.1 <sup>+0.6</sup>	59.4	160	46.5	31	
			4 1/2" x 4 1/2" x 3"	125 x 125 x 90	25.1	18.1	123.9 <sup>+1.2</sup>	123.5 <sup>+1.2</sup>	99.7	89.3 <sup>+0.6</sup>	87.9 <sup>+0.6</sup>	71.6	172	46.5	35.5			

ITEM DESCRIPTION	PICTURE	CODE			DN	S	D <sub>1</sub>	D <sub>2</sub>	L	L <sub>1</sub>	L <sub>2</sub>	H <sub>1</sub>	H <sub>2</sub>	Weight		
		GREEN	WHITE	GRAY	[inc]	[mm]	[mm]	[mm]	[mm]	[mm]	[mm]	[mm]	[mm]	[kg]		
MOUNTING GROUP UN		10003500	10013500	10023500	1/2"	20	4.1	19.0 <sup>+0.3</sup>	19.2 <sup>+0.3</sup>	100		225	14.5	46	34	0.227
										135						
											150					

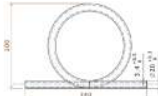
ITEM DESCRIPTION	PICTURE	CODE			DN		e	H	L	Weight
REGULATOR		GREEN	WHITE	GRAY	[inc]	[mm]	[mm]	[mm]	[mm]	[kg]
		10003100	10013100	10023100	½"	20 <sup>+0.3</sup>	3.4 <sup>+0.5</sup>	200	340	

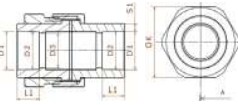
ITEM DESCRIPTION	PICTURE	CODE			DN		S <sub>1</sub>	D <sub>1</sub>	D <sub>2</sub>	D <sub>3</sub>	L <sub>1</sub>	OK	Weight
PPR NUT		GREEN	WHITE	GRAY	[inc]	[mm]	[mm]	[mm]	[mm]	[mm]	[mm]	[mm]	[kg]
					½"	20	3.4	19.2 <sup>+0.3</sup>	19.0 <sup>+0.3</sup>	15.2	14.5	36	
					¾"	25	4.2	24.2 <sup>+0.3</sup>	23.9 <sup>+0.4</sup>	19.4	16	46	
					1"	32	6.5	31.1 <sup>+0.4</sup>	30.9 <sup>+0.4</sup>	25.0	18.1	56	
					1¼"	40	8.1	39.0 <sup>+0.4</sup>	38.8 <sup>+0.4</sup>	31.4	20.5	70	
					1½"	50	10.1	48.9 <sup>+0.5</sup>	48.7 <sup>+0.5</sup>	39.4	23.5	85	
					2"	63	12.7	61.9 <sup>+0.6</sup>	61.6 <sup>+0.5</sup>	49.8	27.4	105	

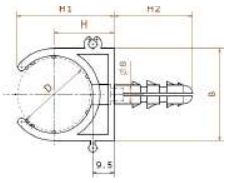
ITEM DESCRIPTION	PICTURE	CODE			DN		B	D <sub>1</sub>	d	d <sub>1</sub>	L	H	H <sub>1</sub>	H <sub>2</sub>	Weight
CLAMP WITH SCREW		GREEN	WHITE	GRAY	[inc]	[mm]	[mm]	[mm]	[mm]	[mm]	[mm]	[mm]	[mm]	[mm]	[kg]
		10003400	10013400	10023400	½"	20	26.4	20.0 <sup>-0.1</sup>	5.4	8.9	12	18	30	28	
		10003401	10013401	10023401	¾"	25	32.8	25.0 <sup>-0.1</sup>	5.4	8.9	13	22	35	34	
		10003402	10013402	10023402	1"	32	40.5	32.0 <sup>-0.2</sup>	5.4	8.9	13.8	26	42	34.5	

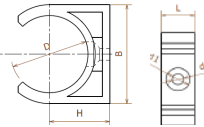
ITEM DESCRIPTION	PICTURE	CODE			DN		H	D <sub>1</sub>	B	d	d <sub>1</sub>	L	Weight
PIPE CLAMP		GREEN	WHITE	GRAY	[inc]	[mm]	[mm]	[mm]	[mm]	[mm]	[mm]	[mm]	[kg]
		10002900	10012900	10022900	½"	20	19	20.0 <sup>-0.1</sup>	28	5.5	10	13.5	0.005
		10002901	10012901	10022901	¾"	25	22	25.0 <sup>-0.1</sup>	35	5.5	10	13.5	0.007
		10002802	10012802	10022802	1"	32	25	32.0 <sup>-0.2</sup>	41	5.5	10	14.2	0.009
		10002803	10012803	10022803	1¼"	40	30	40.0 <sup>-0.2</sup>	50	5.5	10	15.2	0.017

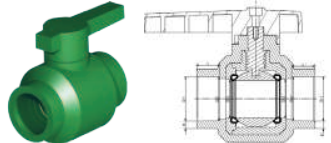
ITEM DESCRIPTION	PICTURE	CODE			DN		E	D <sub>1</sub>	D <sub>2</sub>	D <sub>3</sub>	L	Weight
BALL VALVE		GREEN	WHITE	GRAY	[inc]	[mm]	[mm]	[mm]	[mm]	[mm]	[mm]	[kg]
		10003700	10013700	10023700	1/2"	20	3.4	19.2 <sup>+0.3</sup>	19.0 <sup>+0.3</sup>	15.5	15.7	0.074
		10003701	10013701	10023701	3/4"	25	4.2	24.2 <sup>+0.3</sup>	23.9 <sup>+0.4</sup>	23	17	0.097
		10003702	10013702	10023702	1"	32	6.5	31.1 <sup>+0.4</sup>	30.9 <sup>+0.4</sup>	24.5	18.7	0.146
		10003703	10013703	10023703	1 1/4"	40	8.1	39.0 <sup>+0.4</sup>	38.8 <sup>+0.4</sup>	34	20.5	
		10003704	10013704	10023704	1 1/2"	50	10.1	48.9 <sup>+0.5</sup>	48.7 <sup>+0.5</sup>	41	23.5	
		10003705	10013705	10023705	2"	63	12.7	61.9 <sup>+0.6</sup>	61.6 <sup>+0.5</sup>	57	27.4	

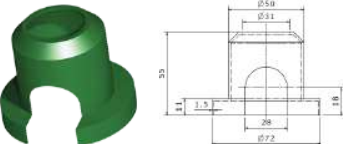
ITEM DESCRIPTION	PICTURE	CODE			S	L	L <sub>1</sub>	L <sub>2</sub>	L <sub>3</sub>	d <sub>1</sub>	d <sub>2</sub>	d <sub>3</sub>	Weight
MASK FOR ELBOW WITH FIX.BRACK		GREEN	WHITE	GRAY	[mm]	[mm]	[mm]	[mm]	[mm]	[mm]	[mm]	[mm]	[kg]
		10001350			1.5	55	18	11	28	31	50	72	

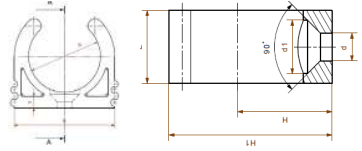
ITEM DESCRIPTION	PICTURE	CODE			DN		e	L	B	D <sub>1</sub>	d	d <sub>1</sub>	H	H <sub>1</sub>	Weight
LOW CLAMP		GREEN	WHITE	GRAY	[inc]	[mm]	[mm]	[mm]	[mm]	[mm]	[mm]	[mm]	[mm]	[mm]	[kg]
		10002850	10012850	10022850	1/2"	20	3.5	13.2	27.5	20.0 <sup>+0.1</sup>	5	9	15	24	
		10002851	10012851	10022851	3/4"	25	4.5	13.7	35	25.0 <sup>+0.1</sup>	5	9	18	30.7	

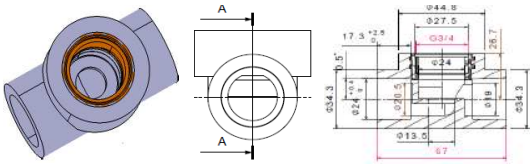
ITEM DESCRIPTION	PICTURE	CODE			DN		G	D <sub>1</sub>	D <sub>2</sub>	d	d <sub>1</sub>	d <sub>2</sub>	d <sub>3</sub>	d <sub>4</sub>	L	L <sub>1</sub>	L <sub>2</sub>	Weight		
VALVE BODY		GREEN	WHITE	GRAY	[inc]	[mm]	[inc]	[mm]	[mm]	[mm]	[mm]	[mm]	[mm]	[mm]	[mm]	[mm]	[mm]	[kg]		
		10002350	10012350	10022350	1/2"	20	1/2"													
		10002351	10012351	10022351	3/4"	25	3/4"	34.3	44.8	24.0 <sup>+0.4</sup>	20.5	19	13.5	27.5	67	26.7	17.3 <sup>+0.5</sup>			
		10002352	10012352	10022352	1"	32	1"													

ITEM DESCRIPTION	PICTURE	OK	D	D <sub>1</sub>	D <sub>2</sub>	d <sub>1</sub>	d <sub>2</sub>	L	L <sub>1</sub>	L <sub>2</sub>	L <sub>3</sub>	L <sub>4</sub>	L <sub>5</sub>	L <sub>6</sub>	L <sub>7</sub>	Weight
3/4" INSERT		[mm]	[mm]	[mm]	[mm]	[mm]	[mm]	[mm]	[mm]	[mm]	[mm]	[mm]	[mm]	[mm]	[mm]	[kg]
		31	33.9 <sup>+0.1</sup>	30.5 <sup>+0.1</sup>	27.5 <sup>+0.1</sup>	24.4 <sup>+0.1</sup>	24.0 <sup>+0.05</sup>	15.6	1.8	1.8	3	2.3	2.8	1.9	2	0.046

ITEM DESCRIPTION	PICTURE	CODE			DN	G	D <sub>1</sub>	D <sub>2</sub>	d	d <sub>1</sub>	d <sub>2</sub>	d <sub>3</sub>	d <sub>4</sub>	L	L <sub>1</sub>	L <sub>2</sub>	Weight
BALL VALVE		GREEN	WHITE	GRAY	[inc]	[mm]	[mm]	[mm]	[mm]	[mm]	[mm]	[mm]	[mm]	[mm]	[mm]	[mm]	[kg]
		10002350	10012350	10022350	1/2"	20	27	37.5	20.0 <sup>+0.25</sup>	19.2 <sup>+0.3</sup>	19.0 <sup>+0.3</sup>	19.2 <sup>+0.3</sup>	19.0 <sup>+0.3</sup>	60	14.5 <sup>+2.5</sup>	14.5 <sup>+2.5</sup>	
		10002351	10012351	10022351	3/4"	25	34.3	44.8	24.0 <sup>+0.4</sup>	24.2 <sup>+0.3</sup>	23.9 <sup>+0.4</sup>	24.2 <sup>+0.3</sup>	23.9 <sup>+0.4</sup>	67	16.0 <sup>+2.5</sup>	16.0 <sup>+2.5</sup>	
		10002352	10012352	10022352	1"	32	43.5	52.7	32.0 <sup>+0.35</sup>	31.1 <sup>+0.4</sup>	30.9 <sup>+0.4</sup>	31.1 <sup>+0.4</sup>	30.9 <sup>+0.4</sup>	98	18.1 <sup>+2.5</sup>	18.1 <sup>+2.5</sup>	

ITEM DESCRIPTION	PICTURE	CODE			DN		G	S <sub>1</sub>	S <sub>2</sub>	D <sub>1</sub>	D <sub>11</sub>	D <sub>22</sub>	L	L <sub>1</sub>	L <sub>2</sub>	Weight
REDUCER		GREEN	WHITE	GRAY	[inc]	[mm]	[inc]	[mm]	[mm]	[mm]	[mm]	[mm]	[mm]	[mm]	[mm]	[kg]
10002200		10012200	10022200		¾" na ½"	25 na 20	4.2 <sup>+0.6</sup>	4.1	25.0 <sup>+0.3</sup>	19.2 <sup>+0.3</sup>	19.0 <sup>+0.3</sup>	39	12.5 <sup>+5.5</sup>	14.5	0.009	
10002205		10012205	10022205		1" na ½"	32 na 20	5.4 <sup>+0.7</sup>	4.1	32.0 <sup>+0.3</sup>	19.2 <sup>+0.3</sup>	19.0 <sup>+0.3</sup>	39	14.6 <sup>+5.5</sup>	14.5	0.018	
10002206		10012206	10022206		1" na ¾"	32 na 25	5.4 <sup>+0.7</sup>	5.1	31.1 <sup>+0.4</sup>	24.2 <sup>+0.3</sup>	23.9 <sup>+0.4</sup>	45	14.6 <sup>+5.5</sup>	16	0.015	
10002210		10012210	10022210		1¼" na ½"	40 na 20	6.7 <sup>+0.8</sup>	4.1	20.0 <sup>+0.25</sup>	19.2 <sup>+0.3</sup>	19.0 <sup>+0.3</sup>	38.15	17.0 <sup>+5.5</sup>	14.5	0.050	
10002211		10012211	10022211		1¼" na ¾"	40 na 25	6.7 <sup>+0.8</sup>	5.1	25.0 <sup>+0.3</sup>	24.2 <sup>+0.3</sup>	23.9 <sup>+0.4</sup>	38.5	17.0 <sup>+5.5</sup>	16	0.049	
10002212		10012212	10022212		1¼" na 1"	40 na 32	6.7 <sup>+0.8</sup>	6.5	40.0 <sup>+0.4</sup>	31.1 <sup>+0.4</sup>	30.9 <sup>+0.4</sup>	51	17.0 <sup>+5.5</sup>	18.1	0.030	
10002220		10012220	10022220		1½" na ½"	50 na 20	8.3 <sup>+1</sup>	4.1	20.0 <sup>+0.25</sup>	19.2 <sup>+0.3</sup>	19.0 <sup>+0.3</sup>	35.15	20.0 <sup>+5.5</sup>	14.5		
10002221		10012221	10022221		1½" na ¾"	50 na 25	8.3 <sup>+1</sup>	5.1	25.0 <sup>+0.3</sup>	24.2 <sup>+0.3</sup>	23.9 <sup>+0.4</sup>	39.77	20.0 <sup>+5.5</sup>	16	0.035	
10002222		10012222	10022222		1½" na 1"	50 na 32	8.3 <sup>+1</sup>	6.5	32.0 <sup>+0.35</sup>	31.1 <sup>+0.4</sup>	30.9 <sup>+0.4</sup>	40.14	20.0 <sup>+5.5</sup>	18.1	0.036	
10002223		10012223	10022223		1½" na 1¼"	50 na 40	8.3 <sup>+1</sup>	8.1	50.0 <sup>+0.5</sup>	39.0 <sup>+0.4</sup>	38.8 <sup>+0.4</sup>	58	20.0 <sup>+5.5</sup>	20.5	0.049	
10002240		10012240	10022240		2" na ½"	63 na 20	10.5 <sup>+1.2</sup>	4.1	20.0 <sup>+0.25</sup>	19.2 <sup>+0.3</sup>	19.0 <sup>+0.3</sup>	59	23.9 <sup>+5.5</sup>	14.5		
10002241		10012241	10022241		2" na ¾"	63 na 25	10.5 <sup>+1.2</sup>	5.1	25.0 <sup>+0.3</sup>	24.2 <sup>+0.3</sup>	23.9 <sup>+0.4</sup>	65	23.9 <sup>+5.5</sup>	16	0.075	
10002242		10012242	10022242		2" na 1"	63 na 32	10.5 <sup>+1.2</sup>	6.5	32.0 <sup>+0.35</sup>	31.1 <sup>+0.4</sup>	30.9 <sup>+0.4</sup>	62	23.9 <sup>+5.5</sup>	18.1	0.075	
10002243		10012243	10022243		2" na 1¼"	63 na 40	10.5 <sup>+1.2</sup>	8.1	40.0 <sup>+0.4</sup>	39.0 <sup>+0.4</sup>	38.8 <sup>+0.4</sup>	65	23.9 <sup>+5.5</sup>	20.5	0.085	
10002244		10012244	10022244		2" na 1½"	63 na 50	10.5 <sup>+1.2</sup>	10.1	63.0 <sup>+0.6</sup>	48.9 <sup>+0.5</sup>	48.7 <sup>+0.5</sup>	69	23.9 <sup>+5.5</sup>	23.5	0.090	
					2½" na ½"	75 na 20	12.5 <sup>+1.4</sup>	4.1	20.0 <sup>+0.25</sup>	19.2 <sup>+0.3</sup>	19.0 <sup>+0.3</sup>	45	27.5 <sup>+5.5</sup>	14.5		
					2½" na ¾"	75 na 25	12.5 <sup>+1.4</sup>	5.1	25.0 <sup>+0.3</sup>	24.2 <sup>+0.3</sup>	23.9 <sup>+0.4</sup>	49.15	27.5 <sup>+5.5</sup>	16		
					2½" na 1"	75 na 32	12.5 <sup>+1.4</sup>	6.5	32.0 <sup>+0.35</sup>	31.1 <sup>+0.4</sup>	30.9 <sup>+0.4</sup>	49	27.5 <sup>+5.5</sup>	18.1		
10002260		10012260	10022260		2½" na 1¼"	75 na 40	12.5 <sup>+1.4</sup>	8.1	40.0 <sup>+0.4</sup>	39.0 <sup>+0.4</sup>	38.8 <sup>+0.4</sup>	49.5	27.5 <sup>+5.5</sup>	20.5	0.099	
10002261		10012261	10022261		2½" na 1½"	75 na 50	12.5 <sup>+1.4</sup>	10.1	50.0 <sup>+0.5</sup>	48.9 <sup>+0.5</sup>	48.7 <sup>+0.5</sup>	49.8	27.5 <sup>+5.5</sup>	23.5	0.102	
10002262		10012262	10022262		2½" na 2"	75 na 63	12.5 <sup>+1.4</sup>	12.7	75.0 <sup>+0.7</sup>	61.9 <sup>+0.6</sup>	61.6 <sup>+0.5</sup>	66	27.5 <sup>+5.5</sup>	27.4	0.168	
10002280		10012280	10022280		3" na 1½"	90 na 50	15.0 <sup>+1.6</sup>	10.1	50.0 <sup>+0.5</sup>	48.9 <sup>+0.5</sup>	48.7 <sup>+0.5</sup>	54.1	32.0 <sup>+5.5</sup>	23.5	0.190	
10002281		10012281	10022281		3" na 2"	90 na 63	15.0 <sup>+1.6</sup>	12.7	63.0 <sup>+1.2</sup>	61.9 <sup>+0.6</sup>	61.6 <sup>+0.5</sup>	55.1	32.0 <sup>+5.5</sup>	27.4	0.174	
10002282		10012282	10022282		3" na 2½"	90 na 75	15.0 <sup>+1.6</sup>	15.1	90.0 <sup>+0.9</sup>	74.3 <sup>+0.6</sup>	73.1 <sup>+0.6</sup>	76	32.0 <sup>+5.5</sup>	31	0.283	
10002290		10012290	10022290		4" na 1½"	110 na 50	18.3 <sup>+2</sup>	10.1	50.0 <sup>+0.5</sup>	48.9 <sup>+0.5</sup>	48.7 <sup>+0.5</sup>	89	38.0 <sup>+5.5</sup>	23.5		
10002291		10012291	10022291		4" na 2"	110 na 63	18.3 <sup>+2</sup>	12.7	63.0 <sup>+1.2</sup>	61.9 <sup>+0.6</sup>	61.6 <sup>+0.5</sup>	85	38.0 <sup>+5.5</sup>	27.4		
10002292		10012292	10022292		4" na 2½"	110 na 75	18.3 <sup>+2</sup>	15.1	75.0 <sup>+0.7</sup>	74.3 <sup>+0.6</sup>	73.1 <sup>+0.6</sup>		38.0 <sup>+5.5</sup>	31	0.374	
10002293		10012293	10022293		4" na 3"	110 na 90	18.3 <sup>+2</sup>	18.1	110.0 <sup>+1</sup>	89.3 <sup>+0.6</sup>	87.9 <sup>+0.6</sup>	88	38.0 <sup>+5.5</sup>	35.5	0.404	
1002320					4½" na 2½"	125 na 75	15.0 <sup>+1.6</sup>	15.1	75.0 <sup>+0.7</sup>	74.3 <sup>+0.6</sup>	73.1 <sup>+0.6</sup>	65	46.5	31		
10002525					4½" na 3"	125 na 90	18.3 <sup>+2</sup>	18.1	90.0 <sup>+0.9</sup>	89.3 <sup>+0.6</sup>	87.9 <sup>+0.6</sup>	70	46.5	35.5		
					4½" na 4"	125 na 110	22.1 <sup>+2.4</sup>	22.1	110.0 <sup>+1</sup>	109.4 <sup>+0.6</sup>	107.7 <sup>+0.6</sup>	89	46.5 <sup>+5.5</sup>	41.5		
					6" na 4"	160 na 110										
					6" na 4½"	160 na 125										
					7" na 4½"	200 na 125										
					7" na 6"	200 na 160										
					9" na 6"	250 na 160										
					9" na 7"	250 na 200										
					12" na 7"	315 na 200										
					12" na 9"	315 na 250										

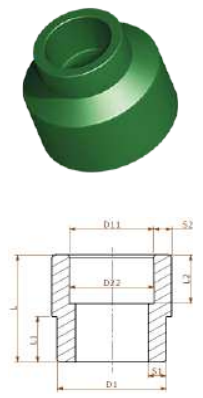

ITEM DESCRIPTION	PICTURE	CODE			DN		G	D	D <sub>1</sub>	D <sub>2</sub>	S <sub>1</sub>	S <sub>2</sub>	L <sub>1</sub>	L <sub>2</sub>	L <sub>3</sub>	L <sub>4</sub>	d <sub>1</sub>	Weight
		GREEN	WHITE	GRAY	[inc]	[mm]	[inc]	[mm]	[mm]	[mm]	[mm]	[mm]	[mm]	[mm]	[mm]	[mm]	[mm]	[mm]
ELBOW 90°-FEMALE THREADED WITH DOUBLE FIX		10001200	10011200	10021200	1/2" x 1/2"	20 x 20	1/2"	19.2 <sup>+0.3</sup>	19.0 <sup>+0.3</sup>	15.2	4.1	5.4	53	37	40	14.5	5.1	0.075
		10001201	10011201	10021201	1/2" x 3/4"	20 x 25	3/4"	24.2 <sup>+0.3</sup>	23.9 <sup>+0.4</sup>	19.4	5.1	5.4	53	37	40	16	5.1	0.088

ITEM DESCRIPTION	PICTURE	CODE			DN		D <sub>1</sub>	D <sub>2</sub>	D <sub>3</sub>	e <sub>1</sub>	G	L <sub>1</sub>	L <sub>2</sub>	L <sub>3</sub>	Weight
		GREEN	WHITE	GRAY	[inc]	[mm]	[mm]	[mm]	[mm]	[mm]	[mm]	[mm]	[mm]	[mm]	[kg]
TEE		10001950	10001950	10001950	1/2"	20 Male	19.2	19	15.2	4.1	1/2"	14.5	26	35	
		10001951	10001951	10001951	3/4"	25 Male	24.2	23.9	19.4	5.1	3/4"	16	26	36	
		10001952	10001952	10001952	1"	32 Male	31.1	30.9	25	6.5	1"	18.1	27	43	

ITEM DESCRIPTION	PICTURE	CODE			DN		D <sub>1</sub>	D <sub>2</sub>	S <sub>1</sub>	G	L <sub>1</sub>	L <sub>2</sub>	L <sub>3</sub>	Weight
		GREEN	WHITE	GRAY	[inc]	[mm]	[mm]	[mm]	[mm]	[mm]	[mm]	[mm]	[mm]	[kg]
TEE - FEMALE THREADED		10001930	10001930	10001930	1/2"	20 Female	19	15.2	4.1	1/2"	14.5	25	36	0.072
		10001931	10001931	10001931	3/4"	25 Female	23.9	19.4	5.1	3/4"	16	26	36	0.150
		10001932	10001932	10001932	1"	32 Female	30.9	25	6.5	1"	18.1	27	40	

ITEM DESCRIPTION	PICTURE	CODE			DN		D <sub>1</sub>	D <sub>2</sub>	D <sub>3</sub>	e <sub>1</sub>	G	L <sub>1</sub>	L <sub>2</sub>	L <sub>3</sub>	Weight
		GREEN	WHITE	GRAY	[inc]	[mm]	[mm]	[mm]	[mm]	[mm]	[inc]	[mm]	[mm]	[mm]	[kg]
ELBOW 90° - MALE THREADED		10001150	10001150	10001150	1/2"	20 Male	19.2	19	15.2	4.1	1/2"	14.5	22	32	0.067
		10001151	10001151	10001151	3/4"	25 Male	24.2	23.9	19.4	5.1	3/4"	16	25	36	0.106
		10001152	10001152	10001152	1"	32 Male	31.1	30.9	25	6.5	1"	18.1	30	40	0.186



ITEM DESCRIPTION	PICTURE	CODE			ND - OD		D <sub>1</sub>	D <sub>2</sub>	e <sub>1</sub>	G	L <sub>1</sub>	L <sub>2</sub>	L <sub>3</sub>	Weight
ELBOW 90° - FEMALE THREADED		GREEN	WHITE	GRAY	[inc]	[mm]	[mm]	[mm]	[mm]	[inc]	[mm]	[mm]	[mm]	[kg]
		10001100	10011100	10021100	½"	20 Female	19	15.2	4.1	½"	14.5	22	32	0.056
		10001101	10011101	10021101	¾"	25 Female	23.9	19.4	5.1	¾"	16	25	36	0.077
		10001102	10011102	10021102	1"	32 Female	30.9	25	6.5	1"	18.1	30	40	0.198

ITEM DESCRIPTION	PICTURE	CODE			DN	D <sub>2</sub>	D <sub>3</sub>	e <sub>1</sub>	G	L	L <sub>1</sub>	L <sub>2</sub>	Weight	
SOCKET - MALE THREADED		GREEN	WHITE	GRAY	[inc]	[mm]	[mm]	[mm]	[inc]	[mm]	[mm]	[mm]	[kg]	
		10001651	10011651	10021651	½"	20 Male	19	15.6	5.1	½"	57	14.5	34	0.062
		10001652	10011652	10021652	¾"	25 Male	23.9	19.4	5.1	¾"	61	16	36	0.100
		10001653	10011653	10021653	1"	32 Male	30.9	25.0	5.4	1"	73	18.1	43	
		10001654	10011654	10021654	1¼"	40 Male	38.8	31.4	8.1	1¼"	79	20.5	47	
		10001655	10011655	10021655	1½"	50 Male	48.7	39.4	10.1	1½"	87.5	23.5	52.5	
		10001656	10011656	10021656	2"	63 Male	61.6	49.8	12.7	2"	94	27.4	57	

ITEM DESCRIPTION	PICTURE	CODE			DN	D <sub>2</sub>	D <sub>3</sub>	e <sub>1</sub>	G	L	L <sub>1</sub>	L <sub>2</sub>	Weight	
SOCKET - FEMALE THREADED		GREEN	WHITE	GRAY	[inc]	[mm]	[mm]	[mm]	[inc]	[mm]	[mm]	[mm]	[kg]	
		10001651	10011651	10021651	½"	20 Female	19	15.6	5.1	½"	57	14.5	34	0.051
		10001652	10011652	10021652	¾"	25 Female	23.9	19.4	5.1	¾"	61	16	36	0.064
		10001653	10011653	10021653	1"	32 Female	30.9	25.0	5.4	1"	73	18.1	43	
		10001654	10011654	10021654	1¼"	40 Female	38.8	31.4	8.1	1¼"	79	20.5	47	
		10001655	10011655	10021655	1½"	50 Female	48.7	39.4	10.1	1½"	87.5	23.5	52.5	
		10001656	10011656	10021656	2"	63 Female	61.6	49.8	12.7	2"	94	27.4	57	

ITEM DESCRIPTION	PICTURE	CODE			DN		D	L	e	H	Weight
BRIDGE		GREEN	WHITE	GRAY	[inc]	[mm]	[mm]	[mm]	[mm]	[mm]	[kg]
		10003000	10013000	10023000	½"	20	20	285	3.4	24	0.049
		10003001	10013001	10023001	¾"	25	25	280	4.2	33	0.076
		10003002	10013002	10023002	1"	32	32	265	5.4	40	0.125

ITEM DESCRIPTION	PICTURE	CODE			DN		D <sub>1</sub>	D <sub>2</sub>	e <sub>1</sub>	L	L <sub>1</sub>	Weight
END CAP		GREEN	WHITE	GRAY	[inc]	[mm]	[mm]	[mm]	[mm]	[mm]	[mm]	[kg]
	10002400	10012400	10022400	1/2"	20	19.2	19	4.1	19	14.5	0.006	
	10002401	10012401	10022401	3/4"	25	24.2	23.9	5.1	23	16	0.011	
	10002402	10012402	10022402	1"	32	31.1	30.9	6.5	26	18.1	0.020	
	10002403	10012403	10022403	1 1/4"	40	39	38.8	8.1	35	20.5	0.048	
	10002404	10012404	10022404	1 1/2"	50	48.9	48.7	10.1	38	23.5	0.084	
	10002405	10012405	10022405	2"	63	61.9	61.6	12.7	41	27.4	0.151	
	10002406	10012406	10022406	2 1/2"	75	74.3	73.1	15.1	51	30	0.221	
	10002407	10012407	10022407	3"	90	89.3	87.9	18.1	58	33	0.364	
	10002810			4 1/2"	125	124.4	123.2	25.1	76	37	0.924	
				6"	160	160	160.0 <sup>+15</sup>	50	74	50		

ITEM DESCRIPTION	PICTURE	CODE			DN		D <sub>2</sub>	D <sub>3</sub>	e <sub>1</sub>	L <sub>1</sub>	L	Weight
ELBOW 90°		GREEN	WHITE	GRAY	[inc]	[mm]	[mm]	[mm]	[mm]	[mm]	[mm]	[kg]
	10001020	10011020	10021020	1/2"	20	19.2	15.2	4.1	14.5	26.5	0.014	
	10001021	10011021	10021021	3/4"	25	24.2	19.4	5.1	16	31.5	0.022	
	10001022	10011022	10021022	1"	32	31.1	25	6.5	18.1	38	0.055	
	10001023	10011023	10021023	1 1/4"	40	39	31.4	8.1	20.5	46	0.106	
	10001024	10011024	10021024	1 1/2"	50	48.9	39.4	10.1	23.5	52	0.158	
	10001025	10011025	10021025	2"	63	61.6	49.8	12.7	27.4	62	0.321	
	10001026	10011026	10021026	2 1/2"	75	74.3	59.4	15.1	30	69	0.436	
	10001027	10011027	10021027	3"	90	89.3	71.6	18.1	33	81	0.730	
	10001028	10011028	10021028	4"	110	109.4	87.6	22.1	37	98	1.926	
	10000209			4 1/2"	125	122.6	99.7	25.1	40	103		

ITEM DESCRIPTION	PICTURE	CODE			DN		D <sub>1</sub>	D <sub>2</sub>	D <sub>3</sub>	L <sub>1</sub>	L <sub>2</sub>	L <sub>3</sub>	e <sub>1</sub>	Weight
STREET 90° - (FEMALE/MALE)		GREEN	WHITE	GRAY	[inc]	[mm]	[mm]	[mm]	[mm]	[mm]	[mm]	[mm]	[mm]	[kg]
	10001550	10011550	10021550	1/2"	20	19	19.2	20	14.5	15.5	22.5	3.4	0.021	
	10001553			3/4"	25	24.2	23.9	16.6	16	12.5	25.3	4.2		
	10001554			1"	32	31.1	30.9	21.2	18.1	14.5	30.7	5.4		

ITEM DESCRIPTION	PICTURE	CODE			DN		D <sub>1</sub>	D <sub>2</sub>	D <sub>3</sub>	e <sub>1</sub>	e <sub>2</sub>	L	L <sub>1</sub>	L <sub>2</sub>	Weight
ELBOW 45° - (FEMALE/MALE)		GREEN	WHITE	GRAY	[inc]	[mm]	[mm]	[mm]	[mm]	[mm]	[mm]	[mm]	[mm]	[mm]	[kg]
	10001570				1/2"	20	19.2 <sup>+0.3</sup>	19.0 <sup>-0.3</sup>	15.2	3.9	3.4	26.5	14.5	14.5	
	10001572				3/4"	25	24.2 <sup>+0.3</sup>	23.9 <sup>+0.4</sup>	19.4	4.8	4.2	31.5	16	16	
	10001573				1"	32	31.1 <sup>+0.4</sup>	30.9 <sup>+0.4</sup>	25	6.1	5.4	38	18.1	18	

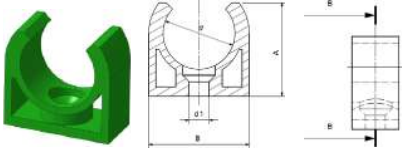
ITEM DESCRIPTION	PICTURE	CODE			DN		d	A	d <sub>1</sub>	B	S	Weight
		GREEN	WHITE	GRAY	[inc]	[mm]	[mm]	[mm]	[mm]	[mm]	[mm]	[kg]
CLAMP - SHORT					1/2"	20	20	26	5.5	28	13.1	

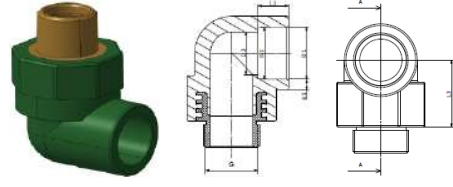
ITEM DESCRIPTION	PICTURE	CODE			DN		e	D <sub>1</sub>	D <sub>2</sub>	D <sub>3</sub>	L <sub>1</sub>	L <sub>3</sub>	G	Weight
		GREEN	WHITE	GRAY	[inc]	[mm]	[mm]	[mm]	[mm]	[mm]	[mm]	[mm]	[inc]	[kg]
TRANSITION ELBOW (W/MALE THREAD) 90° - MALE THREAD					1/2" x 3/4"	20 x 25	4.8	19.2 <sup>+0.3</sup>	19.0 <sup>+0.3</sup>	15.2	14.5	32	3/4"	
		10001500	10011500	10021500	3/4" x 1/2"	25 x 20	4.8	23.9 <sup>+0.4</sup>	23.9 <sup>+0.4</sup>	19.4	16	34	1/2"	

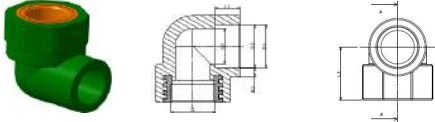
ITEM DESCRIPTION	PICTURE	CODE			DN		e	D <sub>1</sub>	D <sub>2</sub>	D <sub>3</sub>	L <sub>1</sub>	L <sub>3</sub>	G	Weight
		GREEN	WHITE	GRAY	[inc]	[mm]	[mm]	[mm]	[mm]	[mm]	[mm]	[mm]	[inc]	[kg]
TRANSITION ELBOW (W/MALE THREAD) 90° - FEMALE THREAD					1/2" x 3/4"	20 x 25	4.1	19.2 <sup>+0.3</sup>	19.0 <sup>+0.3</sup>	15.2	14.5	32	3/4"	
		10001450	10011450	10021450	3/4" x 1/2"	25 x 20	5.1	24.2 <sup>+0.3</sup>	23.9 <sup>+0.4</sup>	19.4	16	34	1/2"	

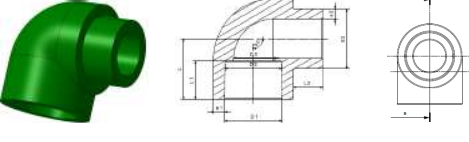
ITEM DESCRIPTION	PICTURE	CODE			DN		D <sub>1</sub>	D <sub>2</sub>	D <sub>3</sub>	e <sub>1</sub>	e <sub>2</sub>	L	L <sub>1</sub>	L <sub>2</sub>	Weight
		GREEN	WHITE	GRAY	[inc]	[mm]	[mm]	[mm]	[mm]	[mm]	[mm]	[mm]	[mm]	[mm]	[kg]
STREET 90° (FEMALE/MALE)					1/2" x 3/4"	20 x 25	24.2 <sup>+0.3</sup>	23.9 <sup>+0.4</sup>	19.4	4.8	3.4	25.5	16	11	

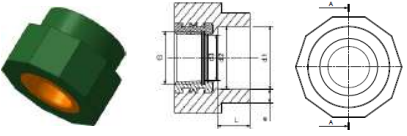
ITEM DESCRIPTION	PICTURE	CODE			DN		e	d <sub>1</sub>	d <sub>2</sub>	d <sub>3</sub>	L	G	Weight
		GREEN	WHITE	GRAY	[inc]	[mm]	[mm]	[mm]	[mm]	[mm]	[mm]	[inc]	[kg]
TRANSITION PIECE (ROUND FEMALE THREAD-HEX)					1/2"	20	3.9	19.2 <sup>+0.3</sup>	19.0 <sup>+0.3</sup>	15.2	14.5	1/2"	
					3/4"	25	4.8	24.2 <sup>+0.3</sup>	23.9 <sup>+0.4</sup>	19.4	16	3/4"	
					1"	32	6.1	31.1 <sup>+0.4</sup>	30.9 <sup>+0.4</sup>	25	18.1	1"	
					1 1/4"	40	7.5	39.0 <sup>+0.4</sup>	38.8 <sup>+0.4</sup>	31.4	20.5	1 1/4"	
					1 1/2"	50	9.3	48.9 <sup>+0.5</sup>	48.7 <sup>+0.5</sup>	39.4	23.5	1 1/2"	
			2"	63	10.5	61.9 <sup>+0.6</sup>	61.6 <sup>+0.5</sup>	49.8	27.5	2"			

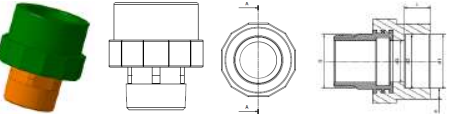
ITEM DESCRIPTION	PICTURE	CODE			DN		e	d <sub>1</sub>	d <sub>2</sub>	d <sub>3</sub>	L	G	Weight
		GREEN	WHITE	GRAY	[inc]	[mm]	[mm]	[mm]	[mm]	[mm]	[mm]	[inc]	[kg]
TRANSITION PIECE (W/ROUND MALE THREAD-HEX)					1/2" x 3/4"	20 x 25	3.9	19.2 <sup>+0.3</sup>	19.0 <sup>+0.3</sup>	15.2	14.5	3/4"	
					3/4" x 1/2"	25 x 20	4.8	24.2 <sup>+0.3</sup>	23.9 <sup>+0.4</sup>	19.4	16	1/2"	
					1" x 3/4"	32 x 25	6.1	31.1 <sup>+0.4</sup>	30.9 <sup>+0.4</sup>	25	18.1	3/4"	
					1 1/4" x 1"	40 x 32	7.5	39.0 <sup>+0.4</sup>	38.8 <sup>+0.4</sup>	31.4	20.5	1"	

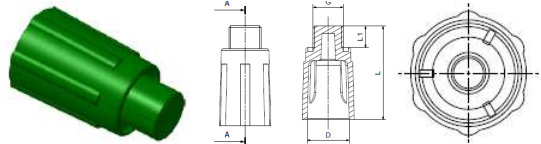
ITEM DESCRIPTION	PICTURE	CODE					DN		D	L	L <sub>1</sub>	G	Weight
		GREEN	WHITE	GRAY	RED	BLUE	[inc]	[mm]	[mm]	[mm]	[mm]	[inc]	[kg]
LONG PLUG FOR PRESSURE							1/2"	20	29	65	15	1/2"	0.020
		10003601	10013601		10043601	10033601	3/4"	25	33	65	15	3/4"	0.024

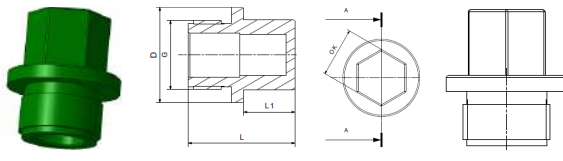
ITEM DESCRIPTION	PICTURE	CODE					DN		D	L	L <sub>1</sub>	G	OK	Weight
		GREEN	WHITE	GRAY	CRVENA	PLAVA	[inc]	[mm]	[mm]	[mm]	[mm]	[inc]	[mm]	[kg]
SHORT PLUG FOR PRESSURE		10002450	10012450	10022450	10042450	10032450	1/2"	20	27.6	31	15	1/2"	18	
		10002451	10012451	10022451	10042451	10032451	3/4"	25	33	25	8.5	3/4"	22	

ITEM DESCRIPTION	PICTURE	CODE UN			DN		e	d <sub>1</sub>	d <sub>2</sub>	L	Weight		
		GREEN	WHITE	GRAY	[inc]	[mm]	[mm]	[mm]	[mm]	[mm]	[kg]		
PLASTIC - PLASTIC NUT CONNECTOR					1/2"	20	3.9	19.2 <sup>+0.3</sup>	19.0 <sup>-0.3</sup>	14.5			
					3/4"	25	4.8	24.2 <sup>+0.3</sup>	23.9 <sup>-0.4</sup>	16			
					1"	32	6.1	31.1 <sup>-0.4</sup>	30.9 <sup>-0.4</sup>	18.1			
					1 1/4"	40	7.5	39.0 <sup>-0.4</sup>	38.8 <sup>-0.4</sup>	20.5			
					1 1/2"	50	9.3	48.9 <sup>-0.5</sup>	48.7 <sup>-0.4</sup>	23.5			
					2"	63	10.5	61.9 <sup>+0.6</sup>	61.6 <sup>-0.5</sup>	27.4			
					CODE SN								
					1/2"	20	3.9	19.2 <sup>+0.3</sup>	19.0 <sup>-0.3</sup>	14.5			
					3/4"	25	4.8	24.2 <sup>+0.3</sup>	23.9 <sup>-0.4</sup>	16			
					1"	32	6.1	31.1 <sup>-0.4</sup>	30.9 <sup>-0.4</sup>	18.1			

ITEM DESCRIPTION	PICTURE	ŠIFRA			DN		e <sub>1</sub> - e <sub>2</sub>	D <sub>1</sub>	D <sub>2</sub>	D <sub>3</sub> - D <sub>33</sub>	L <sub>1</sub>	L <sub>2</sub>	Weight	
		GREEN	WHITE	GRAY	[inc]	[mm]	[mm]	[mm]	[mm]	[mm]	[mm]	[inc]	[mm]	[kg]
CROSS TEE		10002150	10012150	10022150	1/2"	20	4.1	19.2 <sup>-0.3</sup>	19.0 <sup>+0.3</sup>	15.2	14.5	25	0.023	
		10002151	10012151	10022151	3/4"	25	5.1	24.2 <sup>+0.3</sup>	23.9 <sup>-0.4</sup>	19.4	16	26	0.041	

ITEM DESCRIPTION	PICTURE	CODE			DN		d <sub>1</sub>	d <sub>2</sub>	d <sub>3</sub>	e <sub>1</sub>	G	L	Weight
		GREEN	WHITE	GRAY	[inc]	[mm]	[mm]	[mm]	[mm]	[mm]	[inc]	[mm]	[kg]
BACK PLATE TRANSITION ELBOW (W/FEMALE THREAD)		10001202	10011202	10021202	1/2" x 1/2"	20	19.2 <sup>+0.3</sup>	19.0 <sup>-0.3</sup>	15.2	3.9	1/2"	14.5	0.069
		10001206			3/4" x 3/4"	25	24.2 <sup>+0.3</sup>	23.9 <sup>-0.3</sup>	19.4	4.8	3/4"	16	

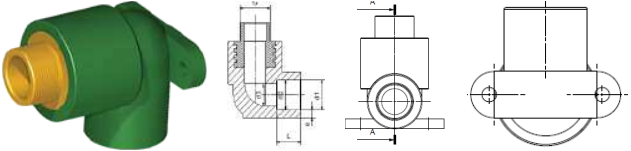
ITEM DESCRIPTION	PICTURE	CODE			DN	D <sub>1</sub>	D <sub>2</sub>	D <sub>3</sub>	e <sub>1</sub>	G	L	Weight	
BACK PLATE TRANSITION ELBOW (MALE THREAD)		GREEN	WHITE	GRAY	[inc]	[mm]	[mm]	[mm]	[mm]	[inc]	[mm]	[kg]	
		10001250	10011250	10021250	1/2" x 1/2"	20	19.2 <sup>+0.3</sup>	19.0 <sup>+0.4</sup>	15.2	3.9	1/2"	14.5	0.086

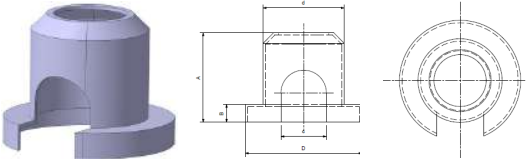
ITEM DESCRIPTION	PICTURE	CODE			D	d	c	B	A	Weight
ELBOW MASK		GREEN	WHITE	GRAY	[mm]	[mm]	[mm]	[mm]	[mm]	[kg]
		10001350	10011350	10021350	72	50	18	11	55	0.015

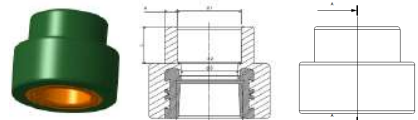
ITEM DESCRIPTION	PICTURE	CODE			DN	e	D <sub>1</sub>	D <sub>2</sub>	D <sub>3</sub>	L	G	Weight
TRANSITION PIECE - FEMALE THREAD		GREEN	WHITE	GRAY	[inc]	[mm]	[mm]	[mm]	[mm]	[mm]	[inc]	[kg]
		10001800	10011800	10021800	1/2" x 3/4"	20 x 25	3.9	24.2 <sup>+0.3</sup>	23.9 <sup>+0.4</sup>	19.4	16	3/4"
		10001801	10011801	10021801	3/4" x 1/2"	25 x 20	4.8	24.2 <sup>+0.3</sup>	23.9 <sup>+0.4</sup>	19.4	16	1/2"
		10001802			1" x 3/4"	32 x 25	6.1	31.1 <sup>+0.4</sup>	30.9 <sup>+0.4</sup>	25	18.1	3/4"
					1 1/4" x 1"	40 x 32	7.5	39.0 <sup>+0.4</sup>	38.8 <sup>+0.4</sup>	31.4	20.5	1"

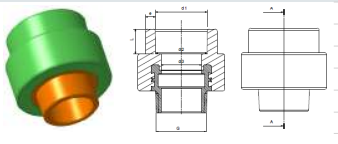
ITEM DESCRIPTION	PICTURE	CODE			DN	e	d <sub>1</sub>	d <sub>2</sub>	d <sub>3</sub>	L	G	Weight
TRANSITION PIECE - MALE THREAD		GREEN	WHITE	GRAY	[inc]	[mm]	[mm]	[mm]	[mm]	[mm]	[inc]	[kg]
		10001850	10011850	10021850	1/2" x 3/4"	20 x 25	4.8	24.2 <sup>+0.3</sup>	23.9 <sup>+0.4</sup>	19.4	16	3/4"
		10001851	10011851	10021851	3/4" x 1/2"	25 x 20	4.8	24.2 <sup>+0.3</sup>	23.9 <sup>+0.4</sup>	19.4	16	1/2"
		10001852			1" x 3/4"	32 x 25	6.1	31.1 <sup>+0.4</sup>	30.9 <sup>+0.4</sup>	25	18.1	3/4"
					1 1/4" x 1"	40 x 32	7.5	39.0 <sup>+0.4</sup>	38.8 <sup>+0.4</sup>	31.4	20.5	1"

ITEM DESCRIPTION	PICTURE	CODE			DN		D <sub>1</sub>	D <sub>2</sub>	D <sub>3</sub> -D <sub>35</sub>	e <sub>1</sub> -e <sub>2</sub>	G	L <sub>1</sub>	L <sub>2</sub>	Weight
		GREEN	WHITE	GRAY	[inc]	[mm]	[mm]	[mm]	[mm]	[mm]	[inc]	[mm]	[inc]	[kg]
BACK PLATE TRANSITION TEE					1/2" x 1/2"	20 x 20	19.2 <sup>+0.3</sup>	19.0 <sup>+0.3</sup>	15.2	4.1	1/2"	14.5	25	0.083
					3/4" x 3/4"	25 x 25	24.2 <sup>+0.3</sup>	23.9 <sup>+0.4</sup>	19.4	5.1	3/4"	16	26	0.108

ITEM DESCRIPTION	PICTURE	CODE			DN		D <sub>1</sub>	D <sub>2</sub>	L	L <sub>1</sub>	Weight	
		GREEN	WHITE	GRAY	[inc]	[mm]	[mm]	[mm]	[mm]	[mm]	[kg]	
REPAIR PLUG					10005002	1/2"	20	7	11	70	40	

ITEM DESCRIPTION	PICTURE	CODE			DN		e	d <sub>1</sub>	d <sub>2</sub>	d <sub>3</sub>	L	G	Weight
		GREEN	WHITE	GRAY	[inc]	[mm]	[mm]	[mm]	[mm]	[mm]	[mm]	[inc]	[kg]
TRANSITION PIECE (W/ HEX MALE THREAD)					1/2"	20	3.9	19.2 <sup>+0.3</sup>	19.0 <sup>+0.3</sup>	15.2	14.5	1/2"	
					3/4"	25	4.8	24.2 <sup>+0.3</sup>	23.9 <sup>+0.4</sup>	19.4	16	3/4"	
					1"	32	6.1	31.1 <sup>+0.4</sup>	30.9 <sup>+0.4</sup>	25	18.1	1"	
					1 1/4"	40	7.5	39.0 <sup>+0.4</sup>	38.8 <sup>+0.4</sup>	31.4	20.5	1 1/4"	
					1 1/2"	50	9.3	48.9 <sup>+0.5</sup>	48.7 <sup>+0.5</sup>	39.4	23.5	1 1/2"	
					2"	63	10.5	61.9 <sup>+0.6</sup>	61.6 <sup>+0.5</sup>	49.8	27.5	2"	

ITEM DESCRIPTION	PICTURE	CODE			DN		d [mm]	D	G	Weight				
		GREEN	WHITE	GRAY	[inc]	[mm]					[mm]	[inc]	[kg]	
SADDLE TRANSITION PIECE (W/MALE THREAD)					1½" na ½"	50 na 20	20	25			50.0 <sup>+0.5</sup>	½"	0.083	
					1½" na ¾"	50 na 25					50.0 <sup>+0.5</sup>	¾"		
					2" na ½"	63 na 20					63.0 <sup>+0.6</sup>	½"		0.120
					2" na ¾"	63 na 25					63.0 <sup>+0.6</sup>	¾"		
					2½" na ½"	75 na 20					75.0 <sup>+0.7</sup>	½"		0.083
					2½" na ¾"	75 na 25					75.0 <sup>+0.7</sup>	¾"		
					3" na ½"	90 na 20					90.0 <sup>+0.9</sup>	½"		0.120
					3" na ¾"	90 na 25					90.0 <sup>+0.9</sup>	¾"		
					4½" na ½"	125 na 20					125.0 <sup>+1.2</sup>	½"		0.084
					4½" na ¾"	125 na 25					125.0 <sup>+1.2</sup>	¾"		
					6" na ½"	160 na 20					160.0 <sup>+1.5</sup>	½"		0.121
					6" na ¾"	160 na 25					160.0 <sup>+1.5</sup>	¾"		

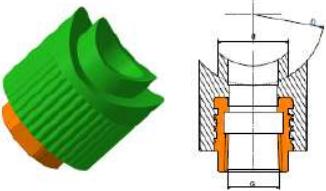
ITEM DESCRIPTION	PICTURE	CODE			DN		d [mm]	D	G	Weight					
		GREEN	WHITE	GRAY	[inc]	[mm]					[mm]	[inc]	[kg]		
SADDLE TRANSITION PIECE (W/FEMALE THREAD)		10002550	10002550	10022550	1¼" na ½"	40 na 20	20	25	32			40.0 <sup>+0.4</sup>	½"		
		10002551	10012551	10022551	1¼" na ¾"	40 na 25						40.0 <sup>+0.4</sup>	¾"		
		10002552	10012552	10022552	1½" na ½"	50 na 20						50.0 <sup>+0.5</sup>	½"		0.071
		10002553	10012553	10022553	1½" na ¾"	50 na 25						50.0 <sup>+0.5</sup>	¾"		0.090
		10002554	10012554	10022554	2" na ½"	63 na 20						63.0 <sup>+0.6</sup>	½"		0.072
		10002555	10012555	10022555	2" na ¾"	63 na 25						63.0 <sup>+0.6</sup>	¾"		0.091
					2½" na ½"	75 na 20						75.0 <sup>+0.7</sup>	½"		0.069
					2½" na ¾"	75 na 25						75.0 <sup>+0.7</sup>	¾"		0.093
					2½" na 1"	75 na 32						75.0 <sup>+0.7</sup>	1"		0.069
					3" na ½"	90 na 20						90.0 <sup>+0.9</sup>	½"		
					3" na ¾"	90 na 25						90.0 <sup>+0.9</sup>	¾"		0.093
					3" na 1"	90 na 32						90.0 <sup>+0.9</sup>	1"		0.070
					4½" na ½"	125 na 20						125.0 <sup>+1.2</sup>	½"		
					4½" na ¾"	125 na 25						125.0 <sup>+1.2</sup>	¾"		0.094
					4½" na 1"	125 na 32						125.0 <sup>+1.2</sup>	1"		0.070
					6" na ½"	160 na 20						160.0 <sup>+1.5</sup>	½"		
					6" na ¾"	160 na 25						160.0 <sup>+1.5</sup>	¾"		0.094
					6" na 1"	160 na 32						160.0 <sup>+1.5</sup>	1"		

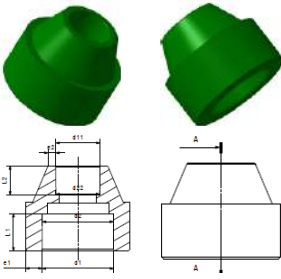
ITEM DESCRIPTION	PICTURE	CODE			DN		e <sub>1</sub>	d <sub>1</sub>	d <sub>2</sub>	e <sub>2</sub>	d <sub>11</sub>	d <sub>22</sub>	L <sub>1</sub>	L <sub>2</sub>	Weight
		GREEN	WHITE	GRAY	[inc]	[mm]	[mm]	[mm]	[mm]	[mm]	[mm]	[mm]	[mm]	[mm]	[mm]
REDUCER		10002300	10012300	10022300	¾" na ½"	25 na 20	4.8	24.2 <sup>+0.3</sup>	23.9 <sup>+0.4</sup>	3.9	19.2 <sup>+0.3</sup>	19.0 <sup>+0.3</sup>	16	14.5	
		10002301	10012301	10022301	1" na ½"	32 na 20	6.1	31.1 <sup>+0.4</sup>	30.9 <sup>+0.4</sup>	3.9	19.2 <sup>+0.3</sup>	19.0 <sup>+0.3</sup>	18.1	14.5	
		10002302	10012302	10022302	1" na ¾"	32 na 25	6.1	31.1 <sup>+0.4</sup>	30.9 <sup>+0.4</sup>	4.8	24.2 <sup>+0.3</sup>	23.9 <sup>+0.4</sup>	18.1	16	
		10002303	10012303	10022303	1¼" na ½"	40 na 20	7.5	39.0 <sup>+0.4</sup>	38.8 <sup>+0.4</sup>	3.9	19.2 <sup>+0.3</sup>	19.0 <sup>+0.3</sup>	20.5	14.5	
		10002304	10012304	10022304	1¼" na ¾"	40 na 25	7.5	39.0 <sup>+0.4</sup>	38.8 <sup>+0.4</sup>	4.8	24.2 <sup>+0.3</sup>	23.9 <sup>+0.4</sup>	20.5	16	

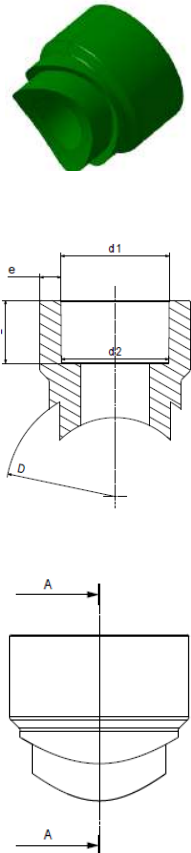

ITEM DESCRIPTION	PICTURE	CODE			DN		D	d <sub>1</sub>	d <sub>2</sub>	L	e	Weight
		GREEN	WHITE	GRAY	[inc]	[mm]	[mm]	[mm]	[mm]	[mm]	[mm]	[kg]
SADDLE		10002500	10012500	10022500	1¼" na ½"	40 na 20	40.0 <sup>+0.4</sup>	19.2 <sup>+0.3</sup>	19.0 <sup>+0.3</sup>	14.5	3.9	0.012
		10002501	10012501	10022501	1¼" na ¾"	40 na 25	40.0 <sup>+0.4</sup>	24.2 <sup>+0.3</sup>	23.9 <sup>+0.4</sup>	16	4.8	0.021
		10002502	10012502	10022502	1½" na ½"	50 na 20	50.0 <sup>+0.5</sup>	19.2 <sup>+0.3</sup>	19.0 <sup>+0.3</sup>	14.5	3.9	0.013
		10002503	10012503	10022503	1½" na ¾"	50 na 25	50.0 <sup>+0.5</sup>	24.2 <sup>+0.3</sup>	23.9 <sup>+0.4</sup>	16	4.8	0.020
		10002504	10012504	10022504	2" na ½"	63 na 20	63.0 <sup>+0.6</sup>	19.2 <sup>+0.3</sup>	19.0 <sup>+0.3</sup>	14.5	3.9	0.014
		10002505	10012505	10022505	2" na ¾"	63 na 25	63.0 <sup>+0.6</sup>	24.2 <sup>+0.3</sup>	23.9 <sup>+0.4</sup>	16	4.8	0.021
		10002506	10012506	10022506	2" na 1"	63 na 32	63.0 <sup>+0.6</sup>	31.1 <sup>+0.4</sup>	30.9 <sup>+0.4</sup>	18.1	6.1	0.022
					2½" na ½"	75 na 20	75.0 <sup>+0.7</sup>	19.2 <sup>+0.3</sup>	19.0 <sup>+0.3</sup>	14.5	3.9	0.012
					2½" na ¾"	75 na 25	75.0 <sup>+0.7</sup>	24.2 <sup>+0.3</sup>	23.9 <sup>+0.4</sup>	16	4.8	0.014
		10002509			2½" na 1"	75 na 32	75.0 <sup>+0.7</sup>	31.1 <sup>+0.4</sup>	30.9 <sup>+0.4</sup>	18.1	6.1	0.022
		10002510			2½" na 1¼"	75 na 40	75.0 <sup>+0.7</sup>	39.0 <sup>+0.4</sup>	38.8 <sup>+0.4</sup>	20.5	7.5	0.041
					3" na ½"	90 na 20	90.0 <sup>+0.9</sup>	19.2 <sup>+0.3</sup>	19.0 <sup>+0.3</sup>	14.5	3.9	0.013
					3" na ¾"	90 na 25	90.0 <sup>+0.9</sup>	24.2 <sup>+0.3</sup>	23.9 <sup>+0.4</sup>	16	4.8	0.015
		10002513			3" na 1"	90 na 32	90.0 <sup>+0.9</sup>	31.1 <sup>+0.4</sup>	30.9 <sup>+0.4</sup>	18.1	6.1	0.023
		10002514			3" na 1¼"	90 na 40	90.0 <sup>+0.9</sup>	39.0 <sup>+0.4</sup>	38.8 <sup>+0.4</sup>	20.5	7.5	0.041
		10002515			4½" na ½"	125 na 20	125.0 <sup>+1.2</sup>	19.2 <sup>+0.3</sup>	19.0 <sup>+0.3</sup>	14.5	3.9	0.014
		10002516			4½" na ¾"	125 na 25	125.0 <sup>+1.2</sup>	24.2 <sup>+0.3</sup>	23.9 <sup>+0.4</sup>	16	4.8	0.015
		10002517			4½" na 1"	125 na 32	125.0 <sup>+1.2</sup>	31.1 <sup>+0.4</sup>	30.9 <sup>+0.4</sup>	18.1	6.1	0.024
		10002518			4½" na 1¼"	125 na 40	125.0 <sup>+1.2</sup>	39.0 <sup>+0.4</sup>	38.8 <sup>+0.4</sup>	20.5	7.5	0.043
		10002519			4½" na 1½"	125 na 50	125.0 <sup>+1.2</sup>	48.9 <sup>+0.5</sup>	48.7 <sup>+0.5</sup>	23.5	9.3	0.081
		10002520			4½" na 2"	125 na 63	125.0 <sup>+1.2</sup>	61.9 <sup>+0.6</sup>	61.6 <sup>+0.5</sup>	27.5	10.5	0.152
					6" na ½"	160 na 20	160.0 <sup>+1.5</sup>	19.2 <sup>+0.3</sup>	19.0 <sup>+0.3</sup>	14.5	3.9	
					6" na ¾"	160 na 25	160.0 <sup>+1.5</sup>	24.2 <sup>+0.3</sup>	23.9 <sup>+0.4</sup>	16	4.8	
					6" na 1"	160 na 32	160.0 <sup>+1.5</sup>	31.1 <sup>+0.4</sup>	30.9 <sup>+0.4</sup>	18.1	6.1	
					6" na 1¼"	160 na 40	160.0 <sup>+1.5</sup>	39.0 <sup>+0.4</sup>	38.8 <sup>+0.4</sup>	20.5	7.5	
					6" na 1½"	160 na 50	160.0 <sup>+1.5</sup>	48.9 <sup>+0.5</sup>	48.7 <sup>+0.5</sup>	23.5	9.3	
					6" na 2"	160 na 63	160.0 <sup>+1.5</sup>	61.9 <sup>+0.6</sup>	61.6 <sup>+0.5</sup>	27.5	10.5	
					6" na 2½"	160 na 75	160.0 <sup>+1.5</sup>	74.3 <sup>+0.6</sup>	73.1 <sup>+0.6</sup>	30	12.5	
					6" na 3"	160 na 90	160.0 <sup>+1.5</sup>	89.3 <sup>+0.6</sup>	87.9 <sup>+0.6</sup>	33	15	
					6" na 4"	160 na 110	160.0 <sup>+1.5</sup>	109.4 <sup>+0.6</sup>	107.7 <sup>+0.6</sup>	37.3	18.38	
					7" na ½"	200 na 20	200.0 <sup>+2.0</sup>	19.2 <sup>+0.3</sup>	19.0 <sup>+0.3</sup>	14.5	3.9	
					7" na ¾"	200 na 25	200.0 <sup>+2.0</sup>	24.2 <sup>+0.3</sup>	23.9 <sup>+0.4</sup>	16	4.8	
					7" na 1"	200 na 32	200.0 <sup>+2.0</sup>	31.1 <sup>+0.4</sup>	30.9 <sup>+0.4</sup>	18.1	6.1	
					7" na 1¼"	200 na 40	200.0 <sup>+2.0</sup>	39.0 <sup>+0.4</sup>	38.8 <sup>+0.4</sup>	20.5	7.5	
					7" na 1½"	200 na 50	200.0 <sup>+2.0</sup>	48.9 <sup>+0.5</sup>	48.7 <sup>+0.5</sup>	23.5	9.3	
					7" na 2"	200 na 63	200.0 <sup>+2.0</sup>	61.9 <sup>+0.6</sup>	61.6 <sup>+0.5</sup>	27.5	10.5	
					7" na 2½"	200 na 75	200.0 <sup>+2.0</sup>	74.3 <sup>+0.6</sup>	73.1 <sup>+0.6</sup>	30	12.5	
					7" na 3"	200 na 90	200.0 <sup>+2.0</sup>	89.3 <sup>+0.6</sup>	87.9 <sup>+0.6</sup>	33	15	
					7" to 4½"	200 na 125	200.0 <sup>+2.0</sup>	124.4 <sup>+0.6</sup>	122.6 <sup>+0.6</sup>	40	20.8	
					9" na 1¼"	250 na 40	250.0 <sup>+2.5</sup>	39.0 <sup>+0.4</sup>	38.8 <sup>+0.4</sup>	20.5	7.5	
			9" na 1½"	250 na 50	250.0 <sup>+2.5</sup>	48.9 <sup>+0.5</sup>	48.7 <sup>+0.5</sup>	23.5	9.3			
			9" na 2"	250 na 63	250.0 <sup>+2.5</sup>	61.9 <sup>+0.6</sup>	61.6 <sup>+0.5</sup>	27.5	10.5			
			9" na 2½"	250 na 75	250.0 <sup>+2.5</sup>	74.3 <sup>+0.6</sup>	73.1 <sup>+0.6</sup>	30	12.5			
			9" na 3"	250 na 90	250.0 <sup>+2.5</sup>	89.3 <sup>+0.6</sup>	87.9 <sup>+0.6</sup>	33	15			
			9" to 4"	250 na 110	250.0 <sup>+2.5</sup>	109.4 <sup>+0.6</sup>	107.7 <sup>+0.6</sup>	37.3	18.38			
			9" to 4½"	250 na 125	250.0 <sup>+2.5</sup>	124.4 <sup>+0.6</sup>	122.6 <sup>+0.6</sup>	40	20.8			
			12" na 2"	315 na 63	315.0 <sup>+2.5</sup>	61.9 <sup>+0.6</sup>	61.6 <sup>+0.5</sup>	27.5	10.5			
			12" na 2½"	315 na 75	315.0 <sup>+2.5</sup>	74.3 <sup>+0.6</sup>	73.1 <sup>+0.6</sup>	30	12.5			
			12" na 3"	315 na 90	315.0 <sup>+2.5</sup>	89.3 <sup>+0.6</sup>	87.9 <sup>+0.6</sup>	33	15			
			12" to 4"	315 na 110	315.0 <sup>+2.5</sup>	109.4 <sup>+0.6</sup>	107.7 <sup>+0.6</sup>	37.3	18.38			
			12" to 4½"	315 na 125	315.0 <sup>+2.5</sup>	124.4 <sup>+0.6</sup>	122.6 <sup>+0.6</sup>	40	20.8			
			12" to 6"	315 na 160	315.0 <sup>+2.5</sup>							

ITEM DESCRIPTION	PICTURE	CODE			DN		d <sub>1</sub> - d <sub>11</sub>	d <sub>2</sub> - d <sub>22</sub>	d <sub>3</sub>	d <sub>33</sub>	e <sub>1</sub> - e <sub>2</sub>	G	L <sub>1</sub>	L <sub>2</sub>	Weight
TRANSITION TEE - MALE THREAD		GREEN	WHITE	GRAY	[inc]	[mm]	[mm]	[mm]	[mm]	[mm]	[mm]	[inc]	[mm]	[inc]	[kg]
		10002100	10002100	10002100	1/2" x 1/2" x 3/4"	20 x 20 x 25 Male	19.2	19	15.2	19.4	4.1	3/8"	14.5	26	
		10002101	10002101	10002101	3/4" x 3/4" x 1/2"	25 x 25 x 20 Male	24.2	23.9	19.4	15.2	5.1	1/2"	16	26	

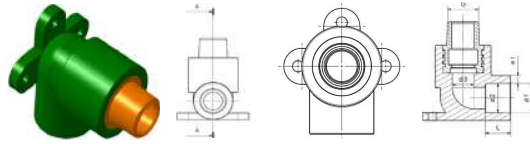
ITEM DESCRIPTION	PICTURE	CODE			DN		d <sub>1</sub>	d <sub>2</sub>	d <sub>3</sub>	e <sub>1</sub>	G	L	Weight
BACK PLATE TRANSITION ELBOW (MALE THREAD)		GREEN	WHITE	GRAY	[inc]	[mm]	[mm]	[mm]	[mm]	[mm]	[inc]	[mm]	[kg]
					3/4" x 1/2"	25 x 20 Male	24.2	23.9	19.4	4.8	1/2"	16	0.069

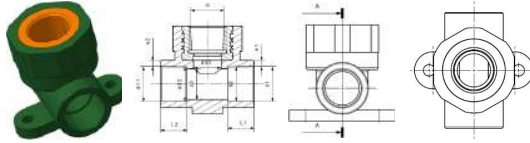
ITEM DESCRIPTION	PICTURE	CODE			DN		d <sub>1</sub> - d <sub>11</sub>	d <sub>2</sub> - d <sub>22</sub>	d <sub>3</sub>	d <sub>33</sub>	e <sub>1</sub> - e <sub>2</sub>	G	L <sub>1</sub>	L <sub>2</sub>	Weight
BACK PLATE TRANSITION TEE - FEMALE THREAD		GREEN	WHITE	GRAY	[inc]	[mm]	[mm]	[mm]	[mm]	[mm]	[mm]	[inc]	[mm]	[mm]	[kg]
		10002190	10002190	10002190	3/4" x 1/2"	25 x 20 Female	24.2	23.9	19.4	15.2	5.1	1/2"	16	26	

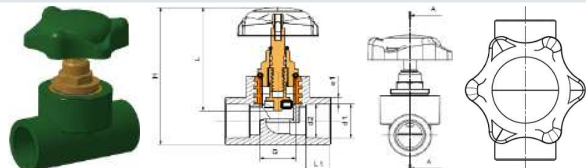
ITEM DESCRIPTION	PICTURE	CODE			DN		d <sub>1</sub>	d <sub>2</sub>	e <sub>1</sub>	G	L <sub>1</sub>	H	L	Weight
SCREW DOWN STOP GLOBE VALVE		GREEN	WHITE	GRAY	[inc]	[mm]	[mm]	[mm]	[mm]	[mm]	[mm]	[mm]	[mm]	[kg]
		10003300	10003300	10003300	1/2"	20	19.2	19	3.9	1/2"	14.5	78.5	57.5	0.029
		10003301	10003301	10003301	3/4"	25	24.2	23.9	4.8	3/4"	16	78.5	57.5	0.045
		10003302	10003302	10003302	1"	32	31.1	30.9	6.1	1"	18.1	78.5	57.5	0.092

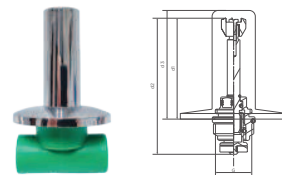
ITEM DESCRIPTION	PICTURE	CODE			DN		d <sub>1</sub>	d <sub>2</sub>	d <sub>3</sub>	G
VALVE SHUTTER - SWIRL		GREEN	WHITE	GRAY	[inc]	[mm]	[mm]	[mm]	[mm]	[mm]
		10004230	10033230	10024230	1/2"	20	71.3	93	76	1/2"
		10004231	10033231	10024231	3/4"	25	71.3	93	76	3/4"
					1"	32	71.3	93	76	1"

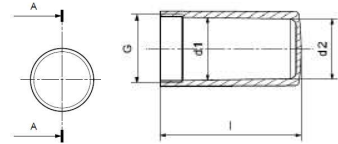
ITEM DESCRIPTION	PICTURE	CODE			DN		d <sub>2</sub>	d <sub>1</sub>	G	I	Weight
VALVE CAP CHROME ABS		GREEN	WHITE	GRAY	[inc]	[mm]	[mm]	[mm]	[inc]	[mm]	[kg]
		10003215	10003215	10003215	1/2"	20	21.5	22.5	3/4"	50	
		10003216	10003216	10003216	3/4"	25	21.5	22.5	3/4"	50	

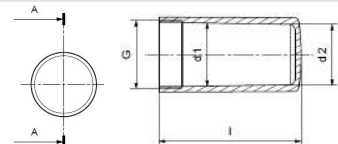
ITEM DESCRIPTION	PICTURE	CODE			ND - OD		d <sub>2</sub>	d <sub>1</sub>	G	I	Weight
VALVE CAP CHROME ABS		GREEN	WHITE	GRAY	[inc]	[mm]	[mm]	[mm]	[inc]	[mm]	[kg]
		10003210	10003210	10003210	1/2"	20	21.5	22.5	3/4"	50	
		10003211	10003211	10003211	3/4"	25	21.5	22.5	3/4"	50	
		10003212	10003212	10003212	1"	32	21.5	22.5	3/4"	50	

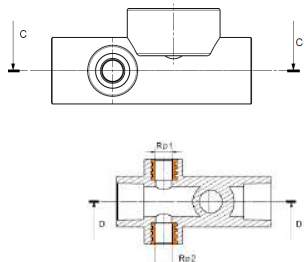
ITEM DESCRIPTION	PICTURE	CODE			DN		d <sub>1</sub>	d <sub>2</sub>	G	e <sub>1</sub>	L	L <sub>1</sub>	RP <sub>1</sub> - RP <sub>2</sub>	Weight
VALVE WITH TWO OUTLETS		GREEN	WHITE	GRAY	[inc]	[mm]	[mm]	[mm]	[mm]	[mm]	[mm]	[mm]	[mm]	[kg]
		10003750	10003750	10003750	1/2"	20	19.2	19	1/2"	3.9	82	14.5	1/8"	
		10003751	10003751	10003751	3/4"	25	24.2	23.9	3/4"	4.8	87	16	1/8"	

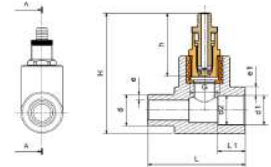
ITEM DESCRIPTION	PICTURE	CODE			DN		d <sub>1</sub>	d <sub>2</sub>	e	G	e <sub>1</sub>	L	L <sub>1</sub>	h	H	Weight
DRAINING VRANCH		GREEN	WHITE	GRAY	[inc]	[mm]	[mm]	[mm]	[mm]	[inc]	[mm]	[mm]	[mm]	[mm]	[mm]	[kg]
		10001930	10001930	10001930	1/2"	20	19.2	19	3.4	1/2"	3.9	58.5	14.5	40	78	
		10001931	10001931	10001931	3/4"	25	24.2	23.9	4.2	3/4"	4.8	58.5	16	40	81	

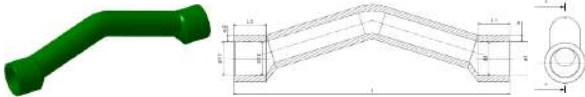
ITEM DESCRIPTION	PICTURE	CODE			DN	d <sub>1</sub> - d <sub>11</sub>	d <sub>2</sub> - d <sub>22</sub>	e <sub>1</sub> - e <sub>2</sub>	l	L <sub>1</sub> - L <sub>2</sub>	Weight
CROSS OVER (INJECTED) - SHORT		GREEN	WHITE	GRAY	[inc]	[mm]	[mm]	[mm]	[inc]	[mm]	[kg]
		10003053	10003053	10003053	1/2"	20	19.2	19	3.9	160	14.5
		10003054	10003054	10003054	3/4"	25	24.2	23.9	4.8	200	16

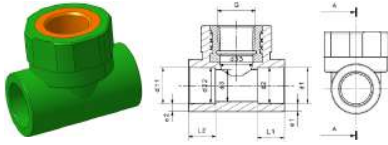
ITEM DESCRIPTION	PICTURE	CODE			DN	d <sub>1</sub> - d <sub>11</sub>	d <sub>2</sub> - d <sub>22</sub>	d <sub>3</sub>	d <sub>33</sub>	e <sub>1</sub> - e <sub>2</sub>	G	L <sub>1</sub>	L <sub>2</sub>	Weight	
TRANSITION TEE - FEMALE THREAD		GREEN	WHITE	GRAY	[inc]	[mm]	[mm]	[mm]	[mm]	[mm]	[inc]	[mm]	[mm]	[kg]	
		10002090	10002090	10002090	1/2» x 1/2» x 3/4"	20 x 20 x 25 Female	19.2	19	15.2	19.4	4.1	3/4"	14.5	26	0.103
		10002091	10002091	10002091	3/4» x 3/4» x 1/2"	25 x 25 x 20 Female	24.2	23.9	19.4	15.2	5.1	1/2"	16	26	0.084

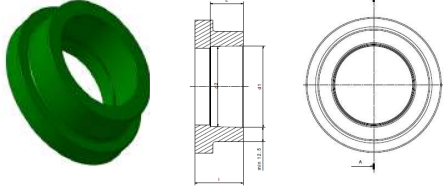
ITEM DESCRIPTION	PICTURE	CODE			DN	D <sub>1</sub>	d <sub>2</sub>	e <sub>1</sub>	L	l	Weight	
QUILL		GREEN	WHITE	GRAY	[inc]	[mm]	[mm]	[mm]	[mm]	[mm]	[kg]	
		10004000	10004000	10004000	1"	32	31.1	30.9	6.1	18.1	23.5	
		10004001	10004001	10004001	1¼"	40	39	38.8	7.5	20.5	27.2	
		10004002	10004002	10004002	1½"	50	48.9	48.7	9.3	23.5	32	0.080
		10004003	10004003	10004003	2"	63	61.9	61.6	10.5	27.5	38	0.128
		10004004	10004004	10004004	2½"	75	74.3	73.1	12.5	30	42.5	0.211
		10004005	10004005	10004005	3"	90	89.3	87.9	15	33	48	0.301
		10004006	10004006	10004006	4"	110	109.4	107.7	18.38	37.7	53	0.792
					4½"	125	124.4	122.6	20.88	40.7	195	
				4½"	125 krađi	124.4	122.6	20.88	40.7	100		

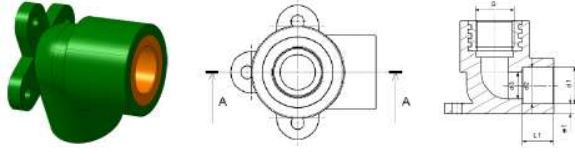
ITEM DESCRIPTION	PICTURE	CODE			DN	d <sub>1</sub>	d <sub>2</sub>	d <sub>3</sub>	e <sub>1</sub>	G	L <sub>1</sub>	Weight
BACK PLATE TRANSITION ELBOW (W/FEMALE THREAD)		GREEN	WHITE	GRAY	[inc]	[mm]	[mm]	[mm]	[mm]	[inc]	[mm]	[kg]
		10001205	10001205	10001205	½» x ¾"	20 x 25 Female	24.2	23.9	19.4	4.8	1/2"	16

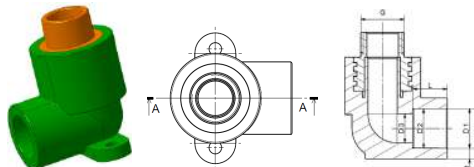
ITEM DESCRIPTION	PICTURE	CODE			DN		D <sub>1</sub>	D <sub>2</sub>	D <sub>3</sub>	e	G	L	Weight
ELBOW 90°-MALE THREADED WITH DOUBLE FIXI		GREEN	WHITE	GRAY	[inc]	[mm]	[mm]	[mm]	[mm]	[mm]	[inc]	[mm]	[kg]
		10001251	10001251	10001251	1/2" x 3/4"	20 x 25 Male	19.2	19	15.2	3.9	3/4"	14.5	

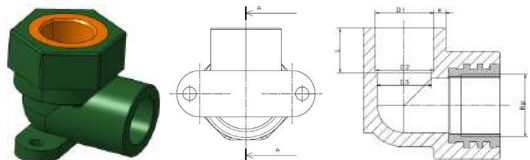
ITEM DESCRIPTION	PICTURE	CODE			DN		D <sub>1</sub>	D <sub>2</sub>	D <sub>3</sub>	e	Rp	L	Weight
ELBOW 90°-FEMALE THREADED WITH DOUBLE FIXI		GREEN	WHITE	GRAY	[inc]	[mm]	[mm]	[mm]	[mm]	[mm]	[inc]	[mm]	[kg]
		10001201	10001201	10001201	1/2" x 3/4"	20 x 25 Female	24.1	23.9	19.4	4.8	3/4"	16	

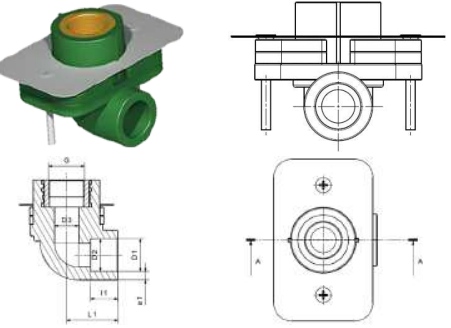
ITEM DESCRIPTION	PICTURE	CODE			DN		D <sub>1</sub>	D <sub>2</sub>	D <sub>3</sub>	e <sub>1</sub>	G	L <sub>1</sub>	I <sub>1</sub>	Weight
RIGIPS ELBOW		GREEN	WHITE	GRAY	[inc]	[mm]	[mm]	[mm]	[mm]	[mm]	[inc]	[mm]	[mm]	[kg]
		10001070	10001070	10001070	1/2"	20	19.2	19	15.2	3.9	1/2"	26.5	14.5	0.091

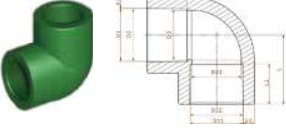
ITEM DESCRIPTION	PICTURE	CODE			DN		d <sub>1</sub> - d <sub>11</sub>	d <sub>2</sub> - d <sub>22</sub>	d <sub>3</sub> - d <sub>33</sub>	S <sub>1</sub> - S <sub>2</sub>	L <sub>1</sub> - L <sub>2</sub>	L	Weight
ELBOW 90°		GREEN	WHITE	GRAY	[inc]	[mm]	[mm]	[mm]	[mm]	[mm]	[mm]	[mm]	[kg]
		10001020	10011020	10021020	1/2"	20	19.2	19	15.2	4.1	14.5	26.5	
		10001021	10011021	10021021	3/4"	25	24.2	23.9	19.4	5.1	16	31.5	
		10001022	10011022	10021022	1"	32	31.1	30.9	25	6.5	18.1	38	
		10001023	10011023	10021023	1 1/4"	40	39	38.8	31.4	8.1	20.5	46	
		10001024	10011024	10021024	1 1/2"	50	48.9	48.7	39.4	10.1	23.5	52	
		10001025	10011025	10021025	2"	63	61.9	61.6	49.8	12.7	27.4	62	
		10001026	10011026	10021026	2 1/2"	75	74.3	73.1	59.4	15.1	31	69	
		10001027	10011027	10021027	3"	90	89.3	87.9	71.6	18.1	35.5	81	
		10001028	10011028	10021028	4"	110	109.4	107	87.6	22.1	41.5	98	
		10000209			4 1/2"	125							

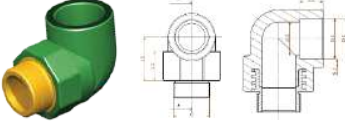
ITEM DESCRIPTION	PICTURE	CODE			DN		D <sub>1</sub>	D <sub>2</sub>	D <sub>3</sub>	e <sub>1</sub>	G	L <sub>1</sub>	L <sub>2</sub>	L <sub>3</sub>	Weight
ELBOW 90° - MALE THREADED		GREEN	WHITE	GRAY	[inc]	[mm]	[mm]	[mm]	[mm]	[mm]	[inc]	[mm]	[mm]	[mm]	[kg]
		10001150	10001150	10001150	1/2"	20 Male	19.2	19	15.2	4.1	1/2"	14.5	22	32	
		10001151	10001151	10001151	3/4"	25 Male	24.2	23.9	19.4	5.1	3/4"	16	25	36	
		10001152	10001152	10001152	1"	32 Male	31.1	30.9	25	6.5	1"	18.1	30	40	

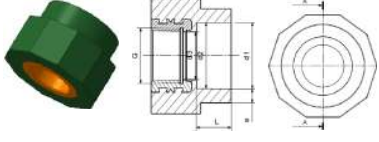
ITEM DESCRIPTION	PICTURE	CODE			DN		D <sub>1</sub>	D <sub>2</sub>	D <sub>3</sub>	e	G	L	Weight
SOCKET - FEMALE THREADED		GREEN	WHITE	GRAY	[inc]	[mm]	[mm]	[mm]	[mm]	[mm]	[inc]	[mm]	[kg]
					1/2" x 3/4"	20 x 25	19.2	19	15.2	3.9	3/4"	14.5	
					3/4" x 1/2"	25 x 20	24.2	23.9	19.4	4.8	1/2"	16	
					1" x 3/4"	32 x 25	31.1	30.9	25	6.1	3/4"	18.1	
					1 1/4" x 3/4"	40 x 32	39	38.8	31.4	7.5	1"	20.5	

ITEM DESCRIPTION	PICTURE	CODE			DN		D <sub>1</sub>	D <sub>2</sub>	D <sub>3</sub>	G	L <sub>1</sub>	L <sub>2</sub>	L <sub>3</sub>	Weight
TEE - MALE THREADED		GREEN	WHITE	GRAY	[inc]	[mm]	[mm]	[mm]	[mm]	[inc]	[mm]	[mm]	[mm]	[kg]
		10001950	10001950	10001950	1/2"	20 Male	19.2	19	15.2	1/2"	14.5	26	35	
		10001951	10001951	10001951	3/4"	25 Male	24.2	23.9	19.4	3/4"	16	26	36	
		10001952	10001952	10001952	1"	32 Male	31.1	30.9	25	1"	18.1	27	43	

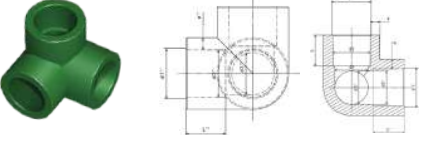
ITEM DESCRIPTION	PICTURE	CODE			DN		d <sub>1</sub> - d <sub>1</sub> ' - d <sub>1</sub> ''	d <sub>2</sub> - d <sub>2</sub> ' - d <sub>2</sub> ''	d <sub>3</sub> - d <sub>3</sub> ' - d <sub>3</sub> ''	e - e' - e''	L <sub>1</sub> - L	Weight
THREE-WAY ELBOW		GREEN	WHITE	GRAY	[inc]	[mm]	[mm]	[mm]	[mm]	[mm]	[mm]	[kg]
		10001050	10001050	10001050	1/2"	20	19.2	19	15.2	3.9	14.5	0.022
		10001051	10001051	10001051	3/4"	25	24.1	23.9	19.4	4.8	16	0.035





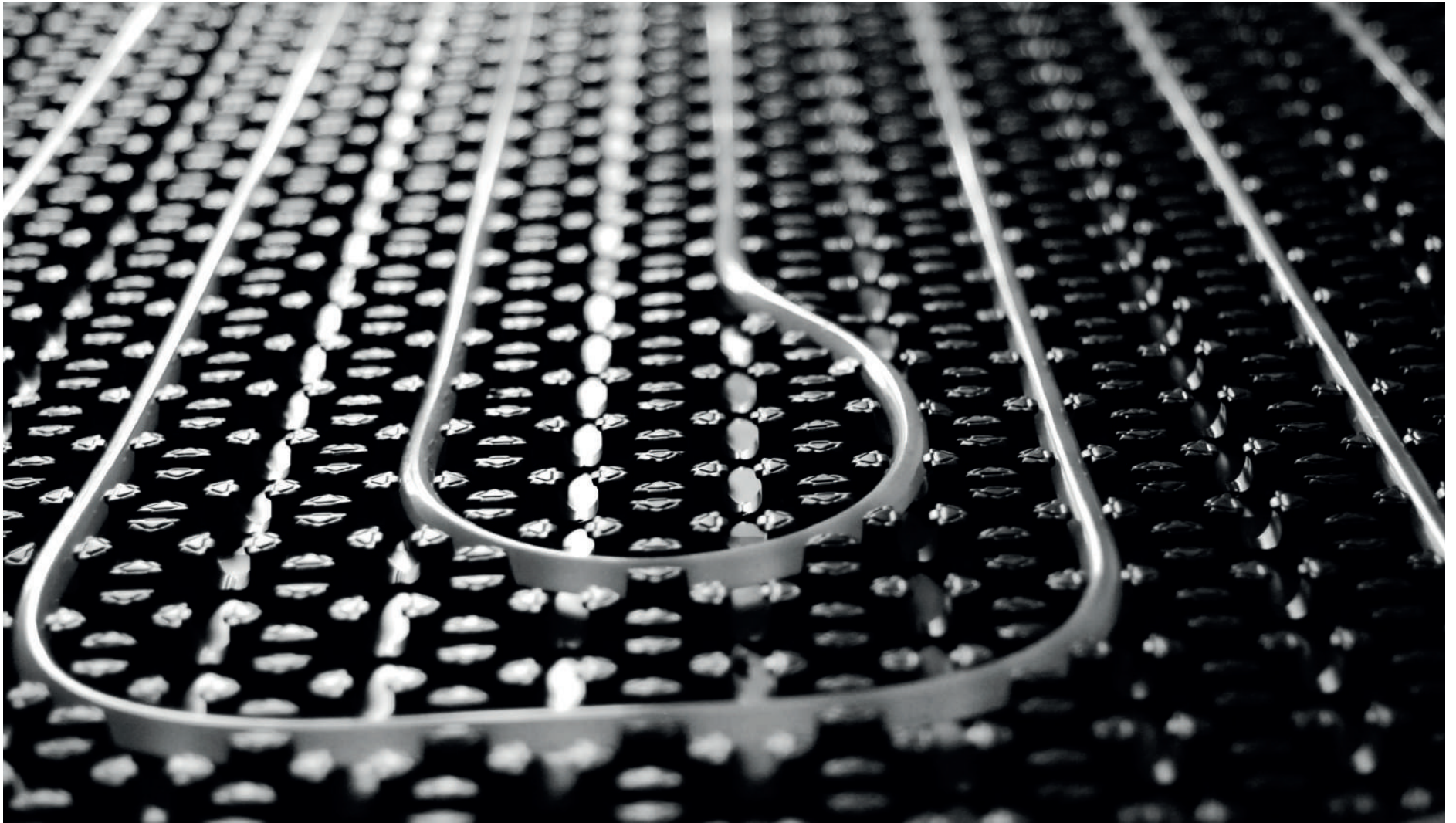



# PERT-AL-PERT

---



Distribution of hot and cold water / Radiator connections / Underfloor heating

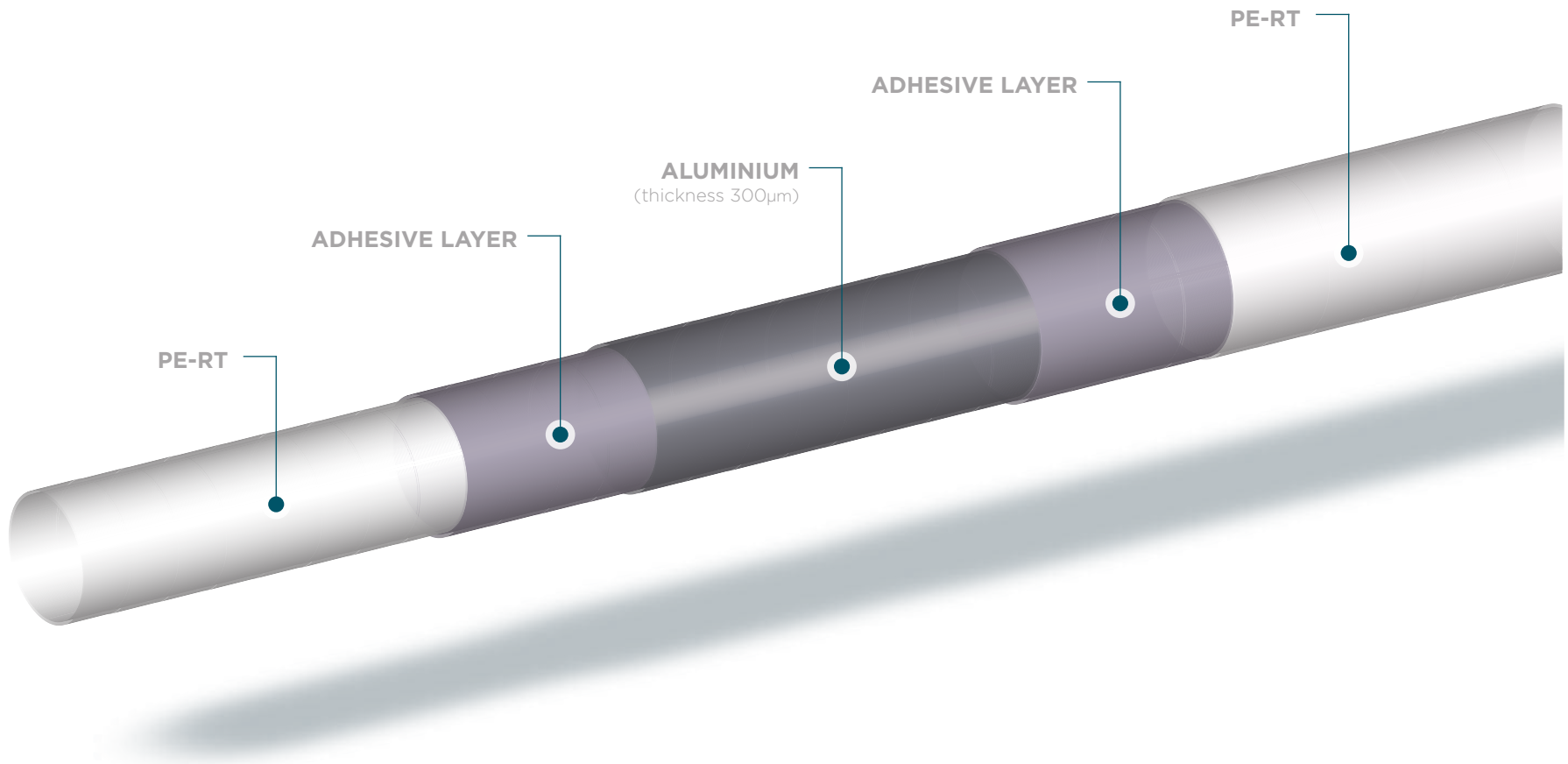

## STRUCTURE OF PERT-AL PIPES

- Inner PE-RT layer
- Adhesive layer
- Aluminium
- Adhesive layer
- Outer layer made of PE-RT

## PROPERTIES OF PERT-AL PIPES

The pipe possesses high resistance to temperature and pressure as well as dimensional stability, impermeability to oxygen, and low thermal expansion.

- The same system for all applications
- Lasting and tight connections
- 100 % oxygen barrier
- Low linear thermal expansion
- Time scale or oxidation will not occur
- Suitable for drinking water supply

## CARACTERISTICS OF PERT-AL PIPES

- Good resistance at elevated temperatures
- Shape stability
- Butt - welding process
- Aluminium thickness is 300 µm
- Coefficient of thermal expansion is 0.024 mm/mK
- Pipes have been tested at 95 °C at 3.9 MPa hydrostatic stress for 22h

## FIELD OF APPLICATION PERT-AL PIPES

- Hot and cold water distribution
- Radiator connections
- Underfloor heating

## CROSS SECTION OF PERT-AL PIPES

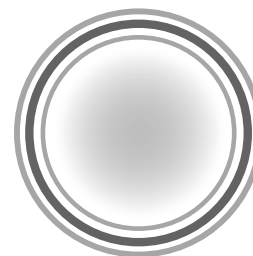

BENDING RADIUS OF  
ALUPEX PIPES IS 5\*OD



Available products PERT-AL pipes **Ø16, Ø20, Ø25, Ø32**

APPLICATION CLASS	T <sub>D</sub> (°C)	TIME ON T <sub>D</sub> (YEAR)	T <sub>max</sub> (°C)	TIME ON T <sub>max</sub> (GODINA)	T <sub>mal</sub> °C	TIME ON T <sub>mal</sub> (SATI)	FIELD OF APPLICATION	PERMISSIBLE OPERATING PRESSURE
1	60	49	80	19	51	00	Hot water (60 °C)	10 bar
2	70	49	80	19	51	00	Hot water (70 °C)	8 bar
	20	2,5						
		+						
4	40	20	70	2,51	00	100	Underfloor heating and low temperature radiators	8 bar
		+						
	60	2,5						
	20	14						
		+						
5	60	25	90	11	00	100	High temperature radiators	8 bar
		+						
	80	10						



# **PRE-INSULATED** PERT-AL-PERT

- Hot and cold water transport
- Central heating (radiator connections)

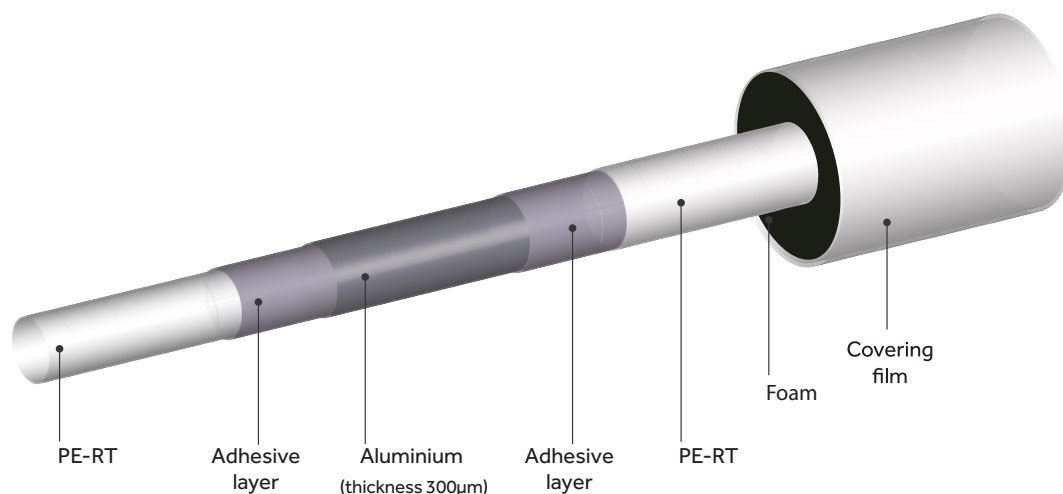

**Technical data:**

Material: Neumreženi polietilen  
 Cell structure: Closed cells structure  
 Thermal conductivity of insulation: <math><0,040\text{W/MK}</math> at 0 °C according to EN12667  
 Aerated water pass trough > according to EN13469  
 Insulation thickness:  $24 \pm 10\%$  kg/m<sup>3</sup> (ISO 845)  
 Insulation color: Grey  
 Insulation width:  $6 \pm 1$  mm according to EN14313:2009+A1: 2013  
 Insulation work temperature up to: +85 °C.  
 Markings: Peštan, EPE Pipe 16/6, datum.  
 Available diameters: Ø16, Ø20, Ø25, Ø32  
 Package: 50 m rolls

Pestán PERT - AL - PERT pipes are being used for radiating heating installations and potable water transportation. Depending on the client's wish they can be produced with or without protective isolation.

Isolation tube is made of expanded polyethylene foam of closed cells structure. It is meant for thermal insulation of pipe systems and complies with all the most important criteria for thermo-isolation of pipe systems by temperatures up to 85 °C.

**Pestán pre-isolated PERT-AL-PERT consists of isolation tube and pipe.**

Isolation tube is made of expanded polyethylene foam of grey color and doesn't contain CFC nor HCFC. Product must be stored in covered and dry area in it's original package.

Pestán PERT-AL-PERT pipes are made of high temperature resistant polyethylene and it has the rest of the high quality components al in accordance with standard and SKZ certificate to support it.

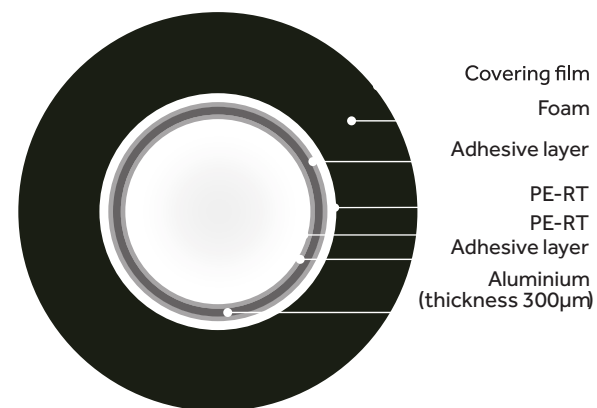



# PE-RT OXY



Five layer pipe with evoh oxygen barrier

PE-RT Oxy five layer pipe is made of polyethylene with raised temperature resistance (PE-RT Type II), which possess good long term hydrostatic strength. PE-RT Type II protect damage of EVOH layer from wear and moisture during transport and construction which ensure the full efficiency of EVOH oxygen barrier during the long period e.g. proposed service life of pipe. EVOH layer doesn't allow diffusion of oxygen into the heating system therefore prevent corrosion of metal parts and devices.

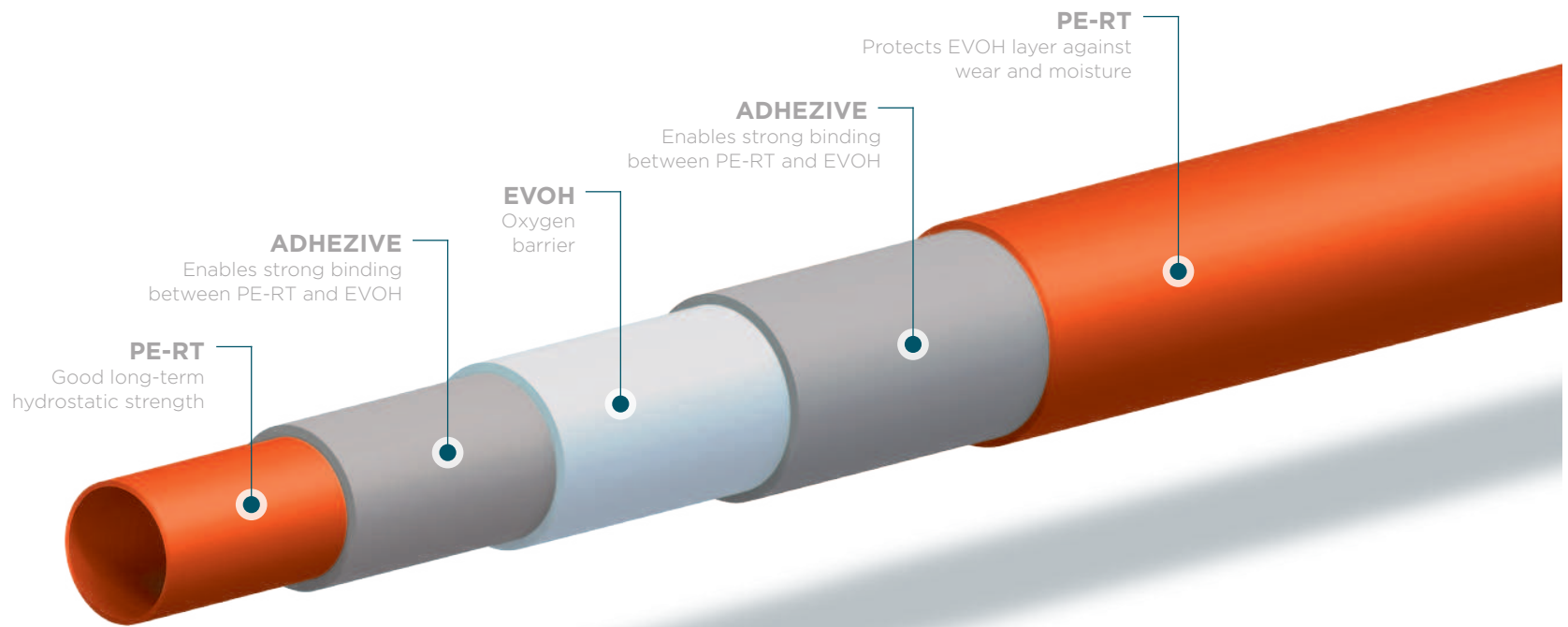

## Characteristics

### PE-RT Oxy

Good long term hydrostatic strength without crosslinking. Fusible with all know welding methods. Very high stress crack resistance. High flexibility. Good creep behavior. It melts on temperatures above 140 °C. It burns on the open flame and turn into CO<sub>2</sub> and water.

## Application

### PE-RT Oxy

Underfloor heating. For hot and cold water distribution Radiator connection

## Product range

- 16 x 2 mm
- 17 x 2 mm
- 18 x 2 mm
- 20 x 2 mm
- 22 x 3 mm
- 28 x 3 mm
- 28 x 4 mm





EVOH layer is in the middle of the pipe so it is fully protected from wear and moisture during transport and construction which ensure the full efficiency of EVOH oxygen barrier during the long period e.g. proposed service life of pipe.

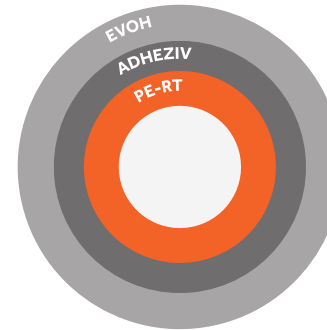

Outer layer of pipe is made of EVOH. Therefore, EVOH is directly exposed to wear and humidity. Oxygen impermeability will decrease with humidity increases.

## APPLICATION CLASSES OF PESTAN PE-RT OXY PIPES (IN ACCORDANCE WITH ISO 22391)

APPLICATION CLASSES	TD (°C)	TIME ON TD (YEARS)	T <sub>max</sub> (°C)	TIME ON T <sub>max</sub> (YEARS)	T <sub>mal</sub> (°C)	TIME ON T <sub>mal</sub> (SATI)	FIELD OF APPLICATION	ALLOWED OPERATING PRESSURE
1	60	49	80	1	95	100	Hot water (60 °C)	10 bar
2	70	49	80	1	95	100	Hot water (70 °C)	8 bar
4	20	2.5	70	2.5	100	100	Underfloor heating and low temperature radiators	8 bar
	40	20						
5	60	2.5	90	1	100	100	High temperature radiators	8 bar
	20	14						
	60	25						
	80	10						

TD - projected temperature  
 T<sub>max</sub> - maximum temperature  
 T<sub>mal</sub> - malfunction temperature

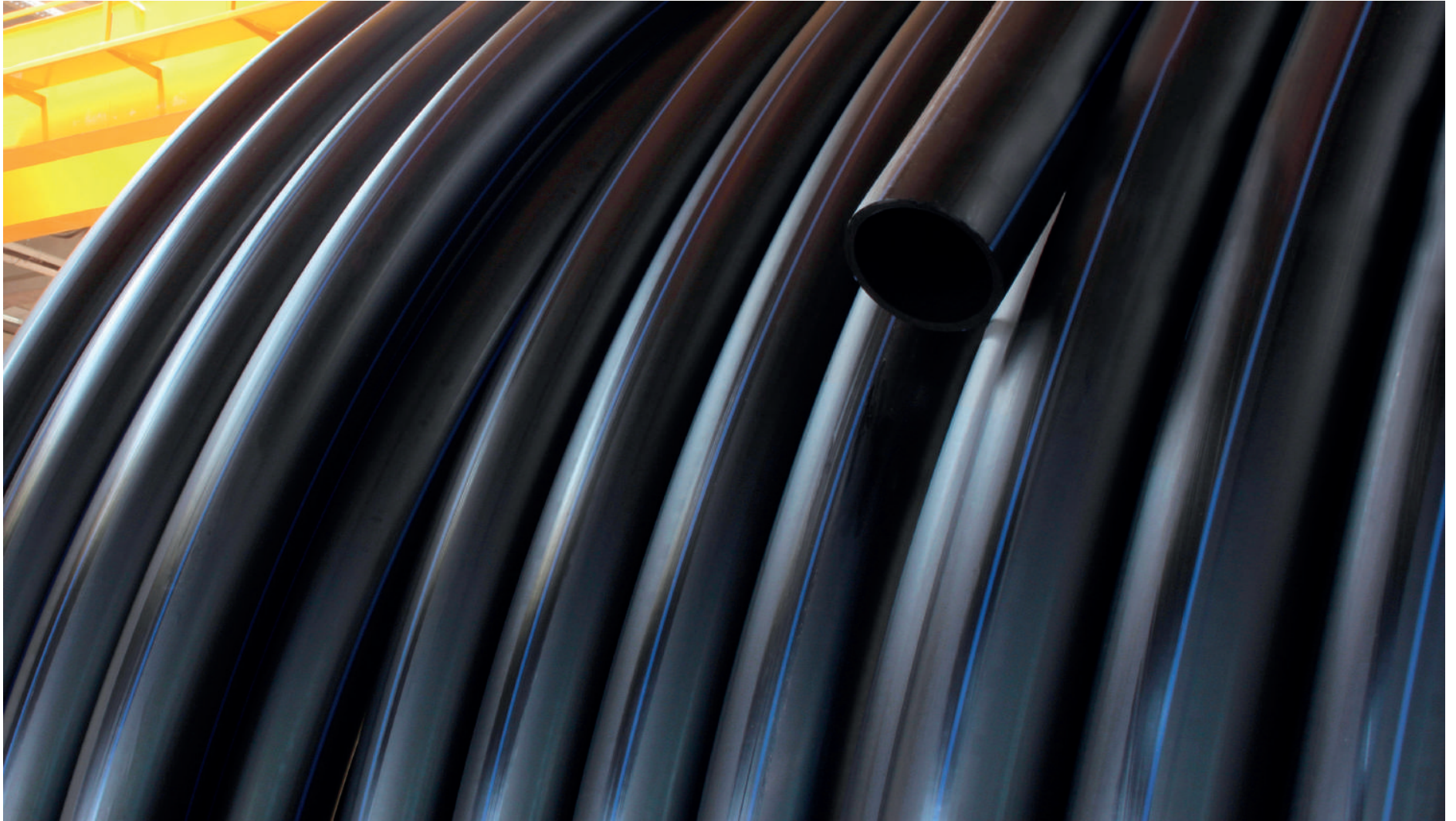

# HDPE WATER PIPES

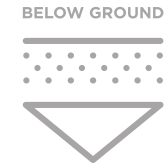

## High Density Polyethylene water pipes PE-80 and PE-100

HDPE water pipes are being manufactured from original High Density Polyethylene PE 80 and PE 100. MRS- classification is MRS=8Mpa, respectively MRS=10Mpa, meaning that pipe will tolerate the same stress 50 years after.

PEŠTAN is using the best raw materials of well-known worldwide raw material suppliers. Quality of products is being monitoring in modern control quality department laboratory. Used materials have a proof of independent European laboratory for MRS classification. Safety coefficient of pipes is 1,25.

Pipes are completely in accordance with SRPS-EN 12201  
Marking of pipes corresponds to European standards.

## Advantages of PE-80 and PE-100 pipes

- Material is absolutely non-toxic and completely inert in contact with water;
- Easy for transport and handling;
- Easy connection by welding or with couplings;
- Life time above 50 years;
- No impact on water taste and smell;
- Tartar free that helps reduction water flow during the time;
- Very flexible and extremely resistant to vibration, seismic strikes and ground movements HDPE 80 pipes are more flexible.
- Pipeline can follow configuration of the ground because of its elasticity that reduces couplings needed
- Bending radius is 20d
- Pipes are UV resistant and resistant to temperatures from -30 °C up to +60 °C
- High abrasion resistance
- Very low pressure losses since coefficient friction are 10 times less than with steel pipes
- Transition from PE80 to PE100 is being done with electric coupling

D (MM)	SDR 6 (S-2,5) PN32		SDR 7,4 (S-3,2) PN25		SDR 9 (S-4) PN20		SDR 11 (S-5) PN16		SDR 13,6 (S-6,3) PN12,5		SDR 17 (S-8) PN10		SDR 21 (S-10) PN8		SDR 26 (S-12,5) PN6		SDR 33 (S-16) PN5		SDR 41 (S-20) PN4	
	e <sub>min</sub>	KG/M	e <sub>min</sub>	KG/M	e <sub>min</sub>	KG/M	e <sub>min</sub>	KG/M	e <sub>min</sub>	KG/M	e <sub>min</sub>	KG/M	e <sub>min</sub>	KG/M	e <sub>min</sub>	KG/M	e <sub>min</sub>	KG/M	e <sub>min</sub>	KG/M
16	3,0	0,15	2,3	0,1	2	0,09														
20	3,4	0,18	3,0	0,154	2,3	0,13	2,	0,12												
25	4,2	0,278	3,5	0,240	3	0,21	2,3	0,17	2,0	0,151	1,9	0,14								
32	5,4	0,454	4,4	0,386	3,6	0,33	3	0,28	2,4	0,228	2	0,2								
40	6,7	0,701	5,5	0,600	4,5	0,51	3,7	0,43	3,0	0,354	2,4	0,29	2,0	0,251						
50	8,3	1,09	6,9	0,936	5,6	0,79	4,6	0,67	3,7	0,550	3	0,45	2,4	0,372	2,0	0,317				
63	10,5	1,73	8,6	1,47	7,1	1,26	5,8	1,06	4,7	0,869	3,8	0,72	3,0	0,586	2,5	0,482				
75	12,5	2,44	10,3	2,09	8,4	1,78	6,8	1,47	5,6	1,23	4,5	1,02	3,6	0,826	2,9	0,682				
90	15,0	3,51	12,3	3,0	10,1	2,56	8,2	2,14	6,7	1,76	5,4	1,46	4,3	1,19	3,5	0,987				
110	18,3	5,24	15,1	4,49	12,3	3,81	10	3,17	8,1	2,63	6,6	2,18	5,3	1,77	4,2	1,45				
125	20,8	6,75	17,1	5,77	14	4,3	11,4	4,11	9,2	3,39	7,4	2,78	6,0	2,28	4,8	1,86				
140	23,3	8,47	19,2	7,25	15,7	6,17	12,7	5,12	10,3	4,25	8,3	3,49	6,7	2,85	5,4	2,35				
160	26,6	11,0	21,9	9,44	17,9	8,04	14,6	6,73	11,8	5,54	9,5	4,55	7,7	3,73	6,2	3,08				
180	29,9	14,0	24,6	11,9	20,1	10,17	16,4	8,5	13,3	7,01	10,7	5,76	8,6	4,69	6,9	3,83				
200	33,2	17,2	27,4	14,8	22,4	12,58	18,2	10,49	14,7	8,65	11,9	7,11	9,6	5,81	7,7	4,74				
225	37,4	21,8	30,8	18,6	25,2	15,92	20,5	13,27	16,6	10,6	13,4	9,01	10,8	7,35	8,6	5,96				
250	41,5	27,0	34,2	23,0	27,9	19,57	22,7	16,33	18,4	13,5	14,8	11,05	11,9	9,03	9,6	7,38				
280	46,5	33,8	38,3	28,9	31,3	24,6	25,4	20,47	20,6	16,9	16,6	13,88	13,4	11,34	10,7	9,2				
315	52,3	42,7	43,1	36,5	35,2	31,11	28,6	25,9	23,2	21,4	18,7	17,57	15,0	14,3	12,1	11,7	9,7	9,7	7,7	7,60
355	59,0	54,3	48,5	46,3	39,7	39,5	32,2	32,88	26,1	27,2	21,1	22,36	16,9	18,2	13,6	14,8	10,9	12,1	8,7	9,6
400			54,7	58,8	44,7	50,12	36,3	41,75	29,4	35,2	23,7	28,27	19,1	23,6	15,3	19,1	12,3	15,7	9,8	12,5
450			61,5	74,4	50,3	62,7	40,9	52,87	33,1	44,6	26,7	35,81	21,5	29,8	17,2	24,2	13,8	19,9	11,0	15,8
500			68,3	92,0	55,8	77,3	45,4	65,24	36,8	55,0	29,7	44,25	23,9	36,9	19,1	29,9	15,3	24,4	12,3	19,4
560					62,5	97	50,8	80,8	41,2	69,0	33,2	55,43	26,7	46,2	21,4	37,5	17,2	30,7	13,7	24,4
630					71	127,6	57,2	102	46,3	87,3	37,4	70,21	30,0	52,9	24,1	47,4	19,3	38,7	15,4	30,8
710					80*	162*	64,5	130	52,2	110,8	42,1	89	33,9	74,2	27,2	60,2	21,8	49,2	17,4	39,0
800					90,1*	205,7*	72,7	170,4	58,8	140,7	47,4	113	38,1	94,0	30,6	76,3	24,5	62,4	19,6	49,5
900							81,7	211,8	66,1	174,9	53,3	143,4	42,9	116,8	34,4	95,1	27,6	76,7	22	61,5
1000							90,8	261,6	73,4	215,9	59,3	177,2	47,7	144,4	38,2	116,9	30,6	94,0	24,5	76,2
1200									88,2	311,1	71,1	254,9	57,2	207,8	45,9	168,4	36,7	135,9	29,4	109,6

\*other sizes are available upon request

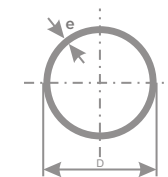
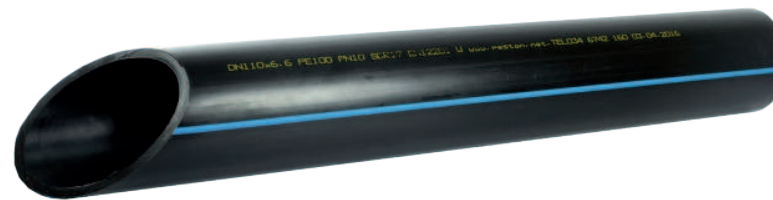

HDPE PE-100

D (MM)	SDR 6 (S-2,5) PN 25		SDR 7,4 (S-3,2) PN 20		SDR 9 (S-4) PN 16		SDR 11 (S-5) PN 12,5		SDR 13,6 (S-6,3) PN 10		SDR 17 (S-8) PN 8		SDR 21 (S-10) PN 6		SDR 26 (S-12,5) PN 5		SDR 33 (S-16) PN 4		SDR 41 (S-20) PN 3,2	
	e <sub>min</sub>	KG/M	e <sub>min</sub>	KG/M	e <sub>min</sub>	KG/M	e <sub>min</sub>	KG/M	e <sub>min</sub>	KG/M	e <sub>min</sub>	KG/M	e <sub>min</sub>	KG/M	e <sub>min</sub>	KG/M	e <sub>min</sub>	KG/M	e <sub>min</sub>	KG/M
16	3,0	0,15	2,3	0,1	2,0	0,09	1,9	0,9	1,8	0,08										
20	3,4	0,18	3,0	0,16	2,3	0,13	2,0	0,12	1,9	0,11										
25	4,2	0,278	3,5	0,24	3,0	0,21	2,3	0,17	2,0	0,15										
32	5,4	0,454	4,4	0,38	3,6	0,32	3,0	0,28	2,4	0,23	2,0	0,2								
40	6,7	0,701	5,5	0,6	4,5	0,56	3,7	0,43	3,0	0,36	2,4	0,29	2,0	0,24						
50	8,3	1,09	6,9	0,93	5,6	0,78	4,6	0,67	3,7	0,54	3,0	0,45	2,4	0,37	2,0	0,317				
63	10,5	1,73	8,6	1,47	7,1	1,25	5,8	1,06	4,7	0,87	3,8	0,72	3,0	0,58	2,5	0,482				
75	12,5	2,44	10,3	2,09	8,4	1,76	6,8	1,47	5,6	1,23	4,5	1,02	3,6	0,82	2,9	0,682				
90	15,0	3,51	12,3	2,99	10,1	2,54	8,2	2,14	6,7	1,76	5,4	1,46	4,3	1,18	3,5	0,987				
110	18,3	5,24	15,1	4,48	12,3	3,77	10,0	3,17	8,1	2,61	6,6	2,18	5,3	1,77	4,2	1,45				
125	20,8	6,75	17,1	5,77	14	4,86	11,4	4,11	9,2	3,36	7,4	2,78	6,0	2,27	4,8	1,86				
140	23,3	8,47	19,2	7,25	15,7	6,11	12,7	5,12	10,3	4,21	8,3	3,49	6,7	2,83	5,4	2,35				
160	26,6	11,0	21,9	9,44	17,9	7,95	14,6	6,73	11,8	5,29	9,5	4,55	7,7	3,72	6,2	3,08				
180	29,9	14,0	24,6	11,9	20,1	10,1	16,4	8,5	13,3	6,74	10,7	5,76	8,6	4,67	6,9	3,83				
200	33,2	17,2	27,4	14,8	22,4	12,4	18,2	10,49	14,7	8,3	11,9	7,11	9,6	5,78	7,7	4,74				
225	37,4	21,8	30,8	18,7	25,2	15,6	20,5	13,27	16,6	10,6	13,4	9,01	10,8	7,30	8,6	5,96				
250	41,5	27,0	34,2	2,3	27,9	19,4	22,7	16,33	18,4	13,4	14,8	11,05	11,9	8,93	9,6	7,38				
280	46,5	33,8	38,3	28,9	31,3	25	25,4	20,47	20,6	16,7	16,6	13,88	13,4	11,3	10,7	9,2				
315	52,3	42,7	43,1	36,6	35,2	30,8	28,6	25,9	23,2	21,2	18,7	17,57	15,0	14,2	12,1	9,7	9,7	7,7	7,60	
355	59,0	54,3	48,5	46,3	39,7	39,1	32,2	32,88	26,1	26,9	21,1	22,36	16,9	18,0	13,6	14,8	10,9	12,1	8,7	9,6
400					44,7	49,6	36,3	41,75	29,4	34,1	23,7	28,27	19,1	22,9	15,3	19,1	12,3	15,7	9,8	12,5
450							40,9	52,87	33,1	43,2	26,7	35,81	21,5	28,9	17,2	24,2	13,8	19,9	11,0	15,8
500							45,4	65,24	36,8	53,4	29,7	44,25	23,9	35,7	19,1	29,9	15,3	24,4	12,3	19,4
560							50,8	80,8	41,2	66,9	33,2	55,43	26,7	44,7	21,4	37,5	17,2	30,7	13,7	24,4
630							57,2	102	46,3	84,6	37,4	70,21	30,0	56,4	24,1	47,4	19,3	38,7	15,4	30,8
710							64,5	130	52,2	109	42,1	89	33,9	71,8	27,2	60,2	21,8	49,2	17,4	39,0
800							72,7	170,4	58,8	138	47,4	113	38,1	91,8	30,6	76,3	24,5	62,4	19,6	49,5

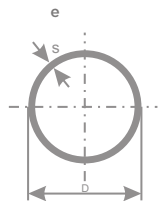

HDPE PE-80





# HDPE RC WATER PIPES

BELOW GROUND

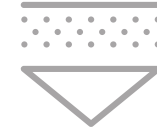

Water pipes made out of high density polyethylene PE 100-RC



## POLYETHYLENE PIPES - BASIC DATA

Polyethylene is the most famous product made of plastic in mass production. It is classic member of polyolefin material family. Chemical formula of PE is  $(CH_2 - CH_2)_n$  which makes it ecologically compatible hydro-carbonic product. Peštan uses for it's production of PE pipes PE-HD, polyethylene of high density that is.

PE-HD pipes are of very high quality for which the tests under the norms DIN EN ISO 12162 and ISO/TR 9080 have proven their life time to be more than 100 years. Practical use also confirms the same, in application in gas, water or sewage networks. PE-HD pipeline systems, some of which are in function for over the 40 years, are characterized by great security in it's usage, low costs of maintenance.

Peštan is offering a wide range of PE pressure pipe systems, designed for potable water, gas (EN 1555 and EN 12201). Peštan pressure pipes are made of polyethylene HD: PE-100.

Positive characteristics of polyethylene pipes are undoubtable. They are firm, resistant in touch with aggressive environment, resistant to corrosion and mechanical impacts. Advantage of PE pipes comparing them to others are: light weight, flexibility, very small pressure loss during friction, toughness in low temperatures, high chemical resistance, good connectivity and low price. PE has a great resistance to acids and greasy substances, insoluble in organic or non organic solvents in temperatures from 20 °C. They are very light and flexible so they offer economical application. Due to it's flexibility very long lines can be layed without using the fittings because pipes can follow the configuration of the grounds, like horizontal turnings of the pipeline routes. By applying PE pipes during the construction of the pipelines the share of fittings and armature in works is minimal. Also the length of pipes can be delivered by special requests for projects, that can diminish building expenses.





## ADVANTAGES OF PE PIPES:

- High reliability and proven performance of functionality make PE a great choice, especially with buried systems;
- Resistance to low temperatures - because of its great expandability PE pipes do not make problems during application and works in low temperatures;
- High resistance to impact - huge resistance to hydraulic impact, fraying and weariness eliminate the need for greater nominal pressures and decreases the values of investment;
- Comparisons have shown that PE pipes have greater resistance to abrasion than the other material, so PE is most wanted for this characteristics when transport of solutes is in question;
- Great hydraulic characteristics - smooth surface and resistance to turbulent flow which allows the flow to be greater;
- High chemical resistance - resistance to vast number of chemicals;
- Ability to get weld - Because of the good flexibility PE pipelines of greater longitude can be connected out of the trench and laid afterwards (which decreases the width of the trench) and welded connections will be strong and reliable;
- Wide spectre of application methods - PE pipes offer to the workers numerous solutions of integration , that can save time and money, for example it is preferred the installation without the trench or with very narrow trench.

## HOW DOES THE NEED FOR REINFORCED AND ENHANCED HDPE PE - 100 APPEAR

Sand coat around the pipe provides simple laying and protection from the rocks and stones. Conventional techniques of pipe placement are proven to be safe and reliable and they guarantee long term function of PE 80 and PE 100.

In last years the workers are more and more turning to new pipe laying techniques. Economic crisis and need for rationalization of spending made numerous producers question the price of making the sand coating for new pipelines and analyzing their necessity. If it is possible put in the dirt dug out from the trench hole it can be used for filling instead of the sand.

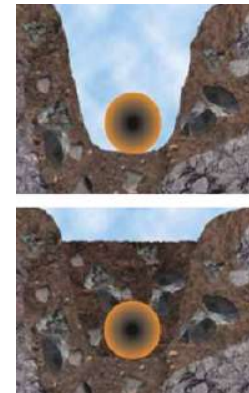

Rejecting the sand coat can result in scratches on the surface of newly placed pipeline. (Permitted damage is 10% of wall thickness) Besides that it is possible that rocks do the pointy or linear pressure the outer wall for a longer period - along with workload such as working pressure, weight of the dirt, or traffic so it could make damage.

If the protective sand coat is rejected it is necessary that chosen pipeline is protected from superficial damage derived from scratches, especially from pointy pressure so it wouldn't make cracks during the strain. So the condition for applying the pipe like this is that the pipe is made of material who can handle the load.

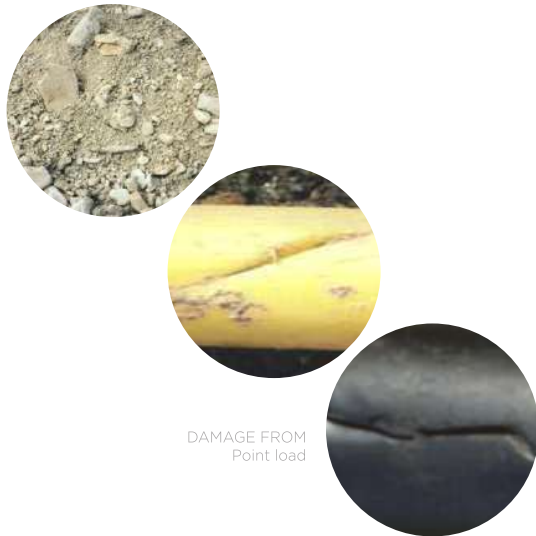

DAMAGE FROM  
Point load

New unconventional techniques have been developed, however, damaging pipes during these techniques can always be avoided which led to the evaluation of pointy load/pressure during the works. New and unconventional techniques are:

- Open trench without sand coating for decreasing spending;
- Laying the pipeline by plowing;
- Directed drilling;
- Relining, breaking the pipeline.



Installation without digging an open trench, method of pipe laying - ploughing



Installation without sand bedding

## ADVANTAGES OF UNCONVENTIONAL METHODS ARE:

- Unconventional methods of installation bring significant decrease of spendings. Decrease of digging costs, bringing the sand and transport... It can all be decreased up to 50%;
- Problems of local inhabitants, decrease of incomes of local stores, redirection and slowed traffic represent indirect spendings of local community that don't occur with unconventional techniques;
- Programs of efficient CO<sub>2</sub> emission are necessary for solving the climate change problems in future. Emission of CO<sub>2</sub> made from bringing the sand and putting away extra dirt from digging the site can be avoided with unconventional methods.
- Time means money and comfort. Swiftness in executing the works makes the difference in the eyes of local inhabitants. Projects too long can be often seen as troublesome and hard bearing while swift projects with unconventional techniques can be done very fast and often unnoticed;
- In total unconventional techniques are good for the environment because of the decreased emission of CO<sub>2</sub>, landscape preservation, trees, land structures...

## PE 100 RC

In manner of responding to challenges of unconventional methods in laying pipes PE 100, to empower resistance to pointy load and pressure and fast spreading of a crack, Borealis has developed new and advanced grain BorSafe HE3490-LS-H. This is the compound that Pestan uses in producing the PE 100 RC pipes.

In business of pipes production the flexibility of two way or multi way process of producing PE material has provided a vast space for production of custom materials. The choice of catalysts, content and selective distribution in their content of polymer chains like the choice of parameters of process in every reactor affect the development of polymer structures and characteristics of final product. Two way process consists of two polymer reactors in row. In picture 1 it is shown the simplified view at basic principle of two way process. On illustration can be seen Borstar® drives with low pressure solution loop and gas phase reactor process. Catalyst enters the first reactor, where the polymer is formed as powder particles and through the polymerization of ethylene monomers and appropriate quantities of the comonomers, continuing in sequence mode in the second reactor.

### THE MAIN ADVANTAGES OF THE PROCESS ARE:

- Applies independent control of the reactor that operates distribution and comonomer adjust the molecular weight distribution (MWD);
- Blink between the reactors guarantee independent reaction mixtures. This may have produced a wide range of densities, from LLDPE to HDPE;
- Various comonomers can be incorporated in accordance with the needs, for example butene and hexene;
- MFR2 of different reactors can vary within a wide range, from 0.1 to << more than 1000 g/10 min;
- The process offers great flexibility as to the type of comonomer that can be incorporated in the correct regions of the polymer. For example, the use of the bimodal comonomer Hacken drives Borstar process results in polymers having an extremely high resistance slow crack growth.

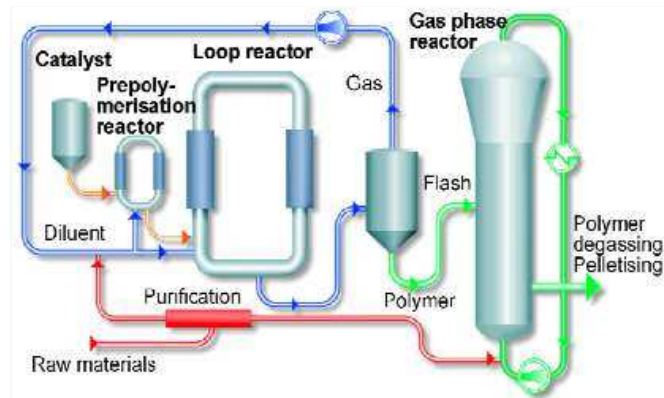

Bimodal polymerisation process Borealis Borstar technology

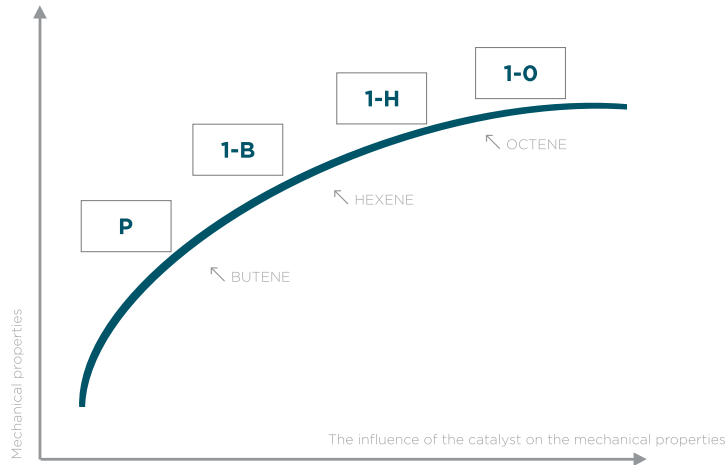

SCG  
**slow crack growth**  
 RCP  
**rapid crack propagation**  
 MRS  
**minimum required strength**

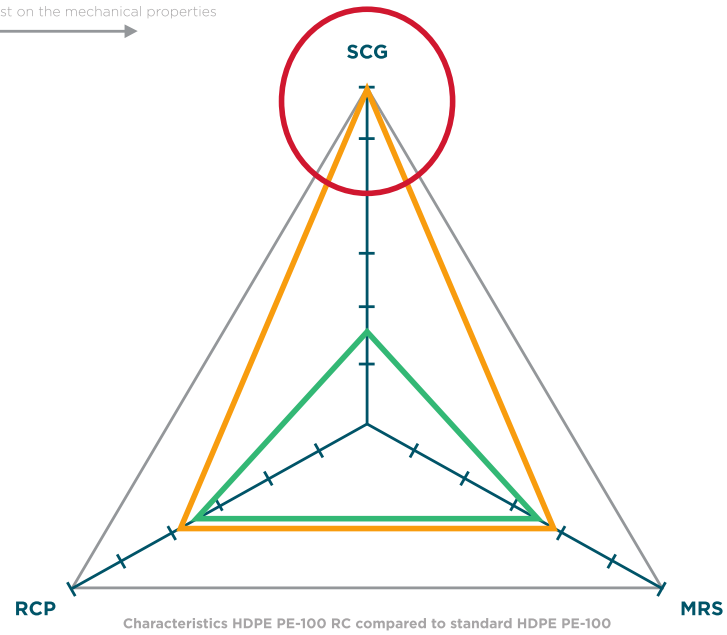

## ESTABLISHIN THE CHARACTERISTICS OF PE 100 RC PIPES

Therefore, PE-HDPE RC 100 is an enhanced HDPE PE-100, which has improved mechanical properties. Improved mechanical properties are the result of a shift catalyst in the process production. Namely, the catalyst for the production of HDPE PE-100 is a butene, and the catalyst is for the production of PE-100 HDPE RC hexene. The assays are described below, indicate the excellent properties RC PE 100 tubing. NPT - notch pipe test, indicating the resistance tube to the recesses that may arise in the trench due exposure pipe stone or the rest of the old pipeline. PLT - point load test demonstrates thinkable tube to point loading, simulating the load that occurs when the tube. Functioning exposed stone walls or a longer period. FNCT - full notch Creep test is the test of raw materials that are produced by PE 100 RC pipe.

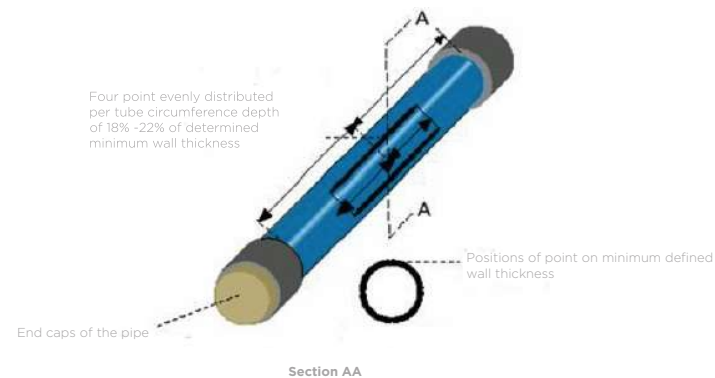

- **Notch test**

is the test method that is used in accordance with EN 12201, EN 1555, ISO4427 and ISO4437, formeasuring the resistance to slow crack growth. Notch test is performed according to ISO 13478 by what a piece of pipe defined cuts and then be tested by releasing water temperature 80 °C under a pressure of 9.2 bar (SDR 11, PE 100) to the moment of cracking.

The results of this test indicate excellent properties HDPE PE 100 RC pipes. The requirements of the standard is more than 500 h, time of cracking of the standard HDPE PE-100 pipe is 1000-2000 h, and at this time in HDPE PE-100 pipe RC increased to 8670 h (one day), which is 4,3 more!



- **Point-Load Test method (PLT)**

is a testing method that simulates stones in a trench without sand cots. Test is performed on a way that the tube, which is exposed to internal pressure, is loaded with the external force (Simulation of a stone). This test was developed by the institute Dr Hassel. In order to shorten the time of cancellation pipes, the medium that is used in this test is not the water, but it is detergent Akropol N 100. Detergent that is placed at a temperature of 80 °C is released under the pressure, and under these conditions the pipe is loaded with external force from 4 N/mm<sup>2</sup>. Under these conditions the time of cancellation HDPE PE 100 RC pipe is >8760 h which means that in the case of loading the water at a temperature of 20 °C, life of the pipe HDPE PE-100 RC is more than 100 years. (Taken from the publication Dr Hassel).



Point load test according to dr. Hassel

- **Full Notched Creep Test**

Test stretching of nicked raw material - is a test in which the test of rod material are cut sharply, and then when it is exposed to the water pool at a temperature of 90 °C with constant stretching, tightening strain of a force is 4 N/mm<sup>2</sup> until they burst. Test simulates local stress concentrations and implemented according to ISO 16770th. How we may have estimate the predicted lifetime of pipes that are under additional point load, Dr. Hassel's engineering and technical testing of pipes are under internal pressure, with additional point load compared with the results of the FNCT test (3RInternational 4/2001 and 6/2001).

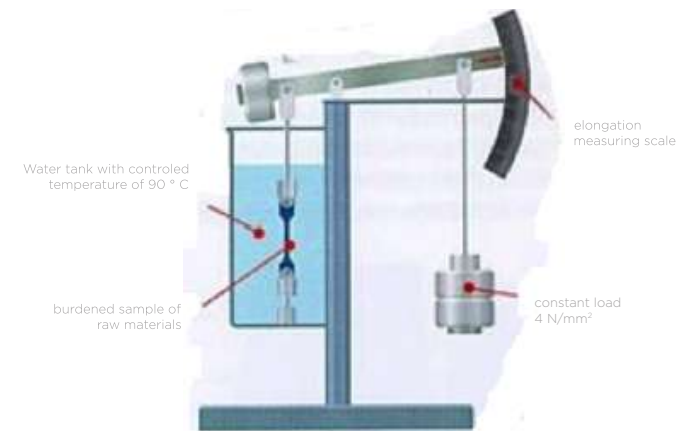

FNCT test - Full Notch Creep-Test (stretching test) (ISO 16770)

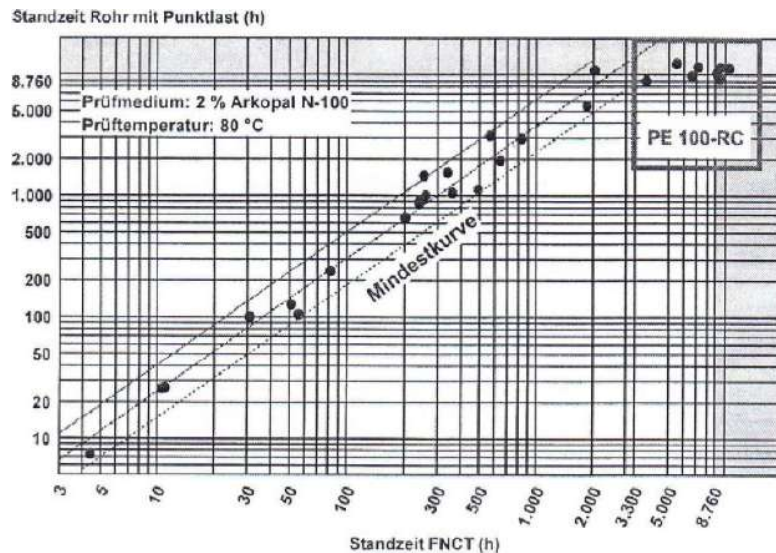

Research Dr Hessel-a is covered with at least 30 test series in three decades with the target size of 8760 hours FNCT test. The correlation coefficient should be >0.9 (dispersion results) with minimum requirements for the lower confidence limit of 2.5% (97.5% points must be above the line). Correlation is accredited in accordance with EN 17025, ISO/IEC. Based on this correlation, the stability of the FNCT-in for at least 2000 hours is taken as proof of the 100-year life of the pipe under concentrated load (Dr. Hessel in the journal 3R International 6/2001).

## PEŠTAN RC

Peštan RC is a compact (full wall) tube made of an innovative, extremely robust plastic BorSafe HE3490-LS-H. Tube prepared like this provides increased security and longer lifetime of pipes compared to traditional PE pipes, even when it comes to extreme loads, such as notching pipes, gutters and spotty loads.

Peštan RC can be easily installed, as well as traditional PE pipes with equal ability. Welding and PE - 100 Pipes and fittings can be connected by connecting areas or electrofusion as well as other standard techniques for joining PE pipes. Peštan RC pipes are compatible with the world's leading manufacturers of fittings. Peštan RC does not require special material for the installation of which is its biggest advantage.

Peštan RC hose thanks to its excellent resistance to stress cracking insensitive to-point loads and therefore did not need her sandy bed.

Peštan's RC tube is flexible and mobile. These properties allow laying in the proceedings of milling. Because of its high resistance to point loading Peštan RC tube is suitable for laying technique in which the soil is excavated and used as fill material.

Open trenches for pipelines threaten undisturbed running of road traffic and disturb nearby residents. Permanently damaging the asphalt on roads. For these reasons technique of laying without digging of a trench is facing the increasing acceptance, since in addition to provide the possibility of laying pipes under rivers, lakes and traffic routes.



## APPLICATION TECHNIQUES FOR PE PIPES

As mentioned earlier a number of techniques have been developed by laying, in order to exploit the benefits of using polyethylene, these techniques are briefly described in text below.

- **Laying in narrow trenches**

This is a modification of the classic pipe laying in the trench. By using short or long ditches you have to dig the trenches that are 100 mm wider than the pipe which is to be installed into ground. Coiled or pre-welded pipes are laid in this passage. Significant savings can be achieved with less excavation volume, the less broth material (sand for bedding) and reduced labor.

- **Pipe bursting**

This is an increasingly popular method for rehabilitation of existing pipeline in places where excavation method is unacceptable. With pipe bursting metode the existing tube is destroyed and a new PE 100 RC pipe is drawn into the resulting hole that provides a replacement with the same diameter pipe or with the help of destroyers, pipe diameter can increase compared to the replased tube

If the situation so requires, Today's hydraulic tools for bursting are capable for damaging the pipe and fittings, and with the further adaptation of tools it is possible to destroy even ductile and steel pipes.

**NOTE.** This method is technically challenging and requires expert trained staff and appropriate equipment. Depending on the material and the status of the old pipe, it may cause scratches and notches on the new pipe. Debris and stones are causing concentrated loads during the exploitation.

- **Laying plowing**

The technique were developed on the basis of Agricultural technology for laying and drain. This method is used for laying of the pipes for water and gas routes between settlements.

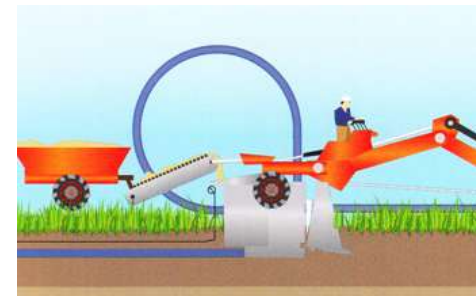
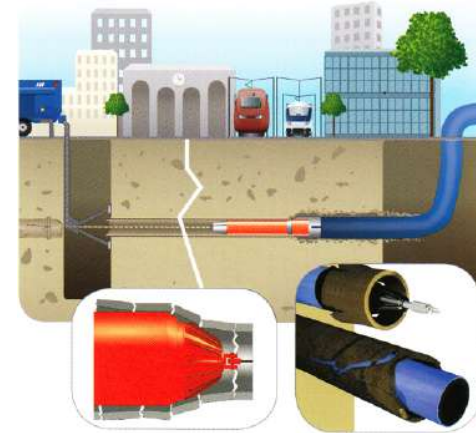

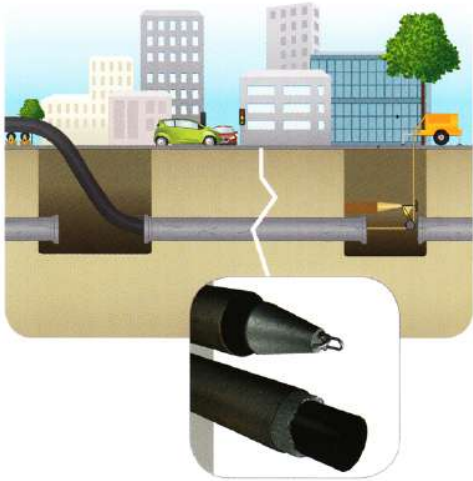

• **Slip lining**

Inserting of a small diameter of PE pipes, slip-lining in the existing Pipeline is one of many techniques for trenchless rehabilitation and repair of old pipeline.

With a slip lining it is inevitable to reduce the pipe diameter, although this can be minimized by thorough cleaning of old pipeline and selecting the largest possible diameter pipe for insertion.

The smaller diameter is compensated by an improved hydraulic characteristics of polyethylene, in some instances we have even higher throughput of the new pipeline.

• **Drilling**

Drilling has become a frequently used method for trenchless setting of small diameters, and can deliver significant savings in relation to the installation of pipes from the excavation. Excavation is carried out for inbound and outbound caves, and it is ideal for passages, drilling pipeline under the road and out of sidewalk construction, gardens and places where there can be disrupted excavation of soils and plants.

Tool drilling is percussion tool with pneumatic motor, that drilled a hole (the tunnel) and in most cases draggas a new PE pipe.

Experienced works contractors are required to perform these techniques installations, in order not to exceed a pre-allowed voltages welded pipe or the spool during threading.

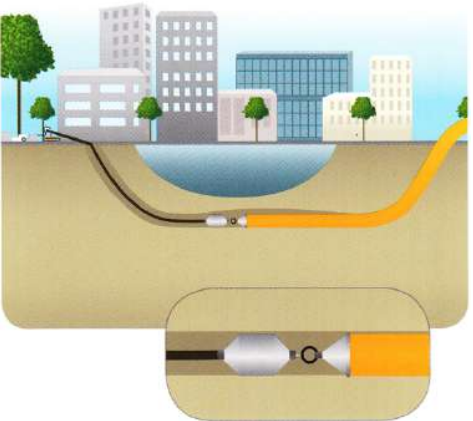

• **Directional drilling**

This technique has also become an established method of installation for polyethylene pipes and it is used for passages under the road, rail railways and rivers and in places where excavation is difficult, expensive or impossible.

## BENDING OF PIPES

One of the main advantages of PE is its flexibility and it can be used as an advantage for buried pipelines. Gradual changes of direction to point of  $11.5^\circ$  can be easily derived through bending of pipes without the need for additional valves and connecting costs.

Accepted rule for Peštan PE pipe systems (in hot conditions for SDR 11 pipes) is bending radius =  $15 \times JV$  (Outer diameter) of pipe. In cold conditions safe bending radius for SDR 17 pipes is  $25 \times S.P.$  For very cold winter, weather conditions of this value increases to  $35 \times JV$  pipe. If you have a pipe with a thin wall, SDR 26 and SDR 33 you should increase this value up to 50%. Fittings and connections should not be installed on sections where the pipe is bent.

## DETECTION OF TUBES

For detection of PE pipeline, the simplest and most economical method is to put in a trench and set with marker tapes that contains wire-track detection. Marker strips should be placed 300 mm above the top of the pipe.

## CHARACTERISTICS AND ADVANTAGES OF THE HDPE PE-100 RC:

- Optimum protection against point source and surface pressure;
- Ideal for trenchless installation and without sand;
- Suitable for all modern welding technology, that can be applied with conventional joining methods used for PE 100;
- A simple and low cost-effective installation, similar to a traditional PE without a need for "Imported" backfill material;
- Very long service of lifetime, even with external damages; excavated earth could be used as backfill material and significantly reduces installation costs;
- Other benefits. All other advantages of standard PE pipe systems are also applicable to Peštan RC, such as for example, cold bending, resistance to hydraulic shock and fatigue of material.

### **All BorSafe LS-H are certified as PE 100-RC (resistant to crack):**

- Approved by independent institutes,
- Recorded in KRV in Germany,
- Regular testing and quality control

# TYPES OF RC PIPES

## Classification of pipe PE 100 RC CEV

There are several combinations of materials for the production of tubes, which allow the PE 100-RC material, and this combination is over minimum requirements applicable to PE 100th.

### Type 1 Solid made of solid wall PE 100-RC

Pipes solid wall of one layer wall are made of PE 100-RC as defined by ISO 4065. These tubes can be made of full-color, blue or black water pipes with blue stripes to the applications which are made of such PE 100 RC materials.



### Type 2 Pipe with dimensionally integrated protective layer made of PE 100-RC

The dual-layered tube is dimensionally integrated with protective layers which are made of PE 100 or PE-100 RC and they have a coextruded layer made of PE 100-RC.

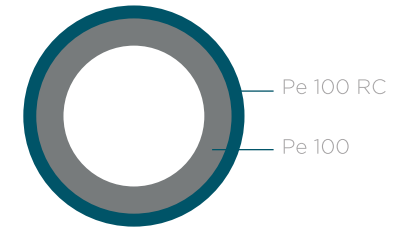

Three-layer pipes with dimensionally integrated protective layers are composed of PE 100 and PE 100 -R c and have inner and outer co-extruded layer made of PE 100-RC. This production is based on a two-layer and three-layer tube with a different outer layer in blue color for water.

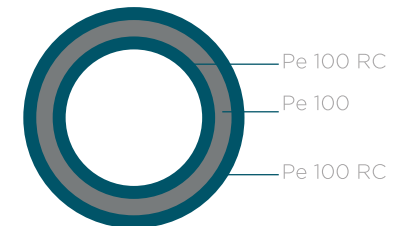

# CATALOG OF PRODUCTS

D (MM)	SDR 6 (S-2,5) PN 32		SDR 7,4 (S-3,2) PN25		SDR 9 (S-4) PN20		SDR 11 (S-5) PN16		SDR 13,6 (S-6,3) PN12,5		SDR17 (S-8) PN10		SDR21 (S-10) PN8		SDR 26 (S-12,5) PN 6		SDR33 (S-16) PN5		SDR41 (S-20) PN4	
	e <sub>min</sub>	KG/M	e <sub>min</sub>	KG/M	e <sub>min</sub>	KG/M	e <sub>min</sub>	KG/M	e <sub>min</sub>	KG/M	e <sub>min</sub>	KG/M	e <sub>min</sub>	KG/M	e <sub>min</sub>	KG/M	e <sub>min</sub>	KG/M	e <sub>min</sub>	KG/M
16	3,0	0,15	2,3	0,1	2	0,09														
20	3,4	0,18	3,0	0,154	2,3	0,13	2	0,12												
25	4,2	0,278	3,5	0,240	3	0,21	2,3	0,17	2,0	0,151	1,9	0,14								
32	5,4	0,454	4,4	0,386	3,6	0,33	3	0,28	2,4	0,228	2	0,2								
40	6,7	0,701	5,5	0,600	4,5	0,51	3,7	0,43	3,0	0,354	2,4	0,29	2,0	0,251						
50	8,3	1,09	6,9	0,936	5,6	0,79	4,6	0,67	3,7	0,550	3	0,45	2,4	0,372	2,0	0,317				
63	10,5	1,73	8,6	1,47	7,1	1,26	5,8	1,06	4,7	0,869	3,8	0,72	3,0	0,586	2,5	0,482				
75	12,5	2,44	10,3	2,09	8,4	1,78	6,8	1,47	5,6	1,23	4,5	1,02	3,6	0,826	2,9	0,682				
90	15,0	3,51	12,3	3,0	10,1	2,56	8,2	2,14	6,7	1,76	5,4	1,46	4,3	1,19	3,5	0,987				
110	18,3	5,24	15,1	4,49	12,3	3,81	10	3,17	8,1	2,63	6,6	2,18	5,3	1,77	4,2	1,45				
125	20,8	6,75	17,1	5,77	14	4,3	11,4	4,11	9,2	3,39	7,4	2,78	6,0	2,28	4,8	1,86				
140	23,3	8,47	19,2	7,25	15,7	6,17	12,7	5,12	10,3	4,25	8,3	3,49	6,7	2,85	5,4	2,35				
160	26,6	11,0	21,9	9,44	17,9	8,04	14,6	6,73	11,8	5,54	9,5	4,55	7,7	3,73	6,2	3,08				
180	29,9	14,0	24,6	11,9	20,1	10,17	16,4	8,5	13,3	7,01	10,7	5,76	8,6	4,69	6,9	3,83				
200	33,2	17,2	27,4	14,8	22,4	12,58	18,2	10,49	14,7	8,65	11,9	7,11	9,6	5,81	7,7	4,74				
225	37,4	21,8	30,8	18,6	25,2	15,92	20,5	13,27	16,6	10,9	13,4	9,01	10,8	7,35	8,6	5,96				
250	41,5	27,0	34,2	23,0	27,9	19,57	22,7	16,33	18,4	13,5	14,8	11,05	11,9	9,03	9,6	7,38				
280	46,5	33,8	38,3	28,9	31,3	24,6	25,4	20,47	20,6	16,9	16,6	13,88	13,4	11,34	10,7	9,2				
315	52,3	42,7	43,1	36,5	35,2	31,11	28,6	25,9	23,2	21,4	18,7	17,57	15,0	14,3	12,1	11,7	9,7	9,7	7,7	7,60
355	59,0	54,3	48,5	46,3	39,7	39,5	32,2	32,88	26,1	27,2	21,1	22,36	16,9	18,2	13,6	14,8	10,9	12,1	8,7	9,6
400			54,7	58,8	44,7	50,12	36,3	41,75	29,4	35,2	23,7	28,27	19,1	23,6	15,3	19,1	12,3	15,7	9,8	12,5
450			61,5	74,4	50,3	62,7	40,9	52,87	33,1	44,6	26,7	35,81	21,5	29,8	17,2	24,2	13,8	19,9	11,0	15,8
500					55,8	77,3	45,4	65,24	36,8	55,0	29,7	44,25	23,9	36,9	19,1	29,9	15,3	24,4	12,3	19,4
560					62,5	97	50,8	80,8	41,2	69,0	33,2	55,43	26,7	46,2	21,4	37,5	17,2	30,7	13,7	24,4
630					71	127,6	57,2	102	46,3	87,3	37,4	70,21	30,0	52,9	24,1	47,4	19,3	38,7	15,4	30,8
710					80*	162*	64,5	130	52,2	110,8	42,1	89	33,9	74,2	27,2	60,2	21,8	49,2	17,4	39,0
800					90,1*	205,7*	72,7	170,4	58,8	140,7	47,4	113	38,1	94,0	30,6	76,3	24,5	62,4	19,6	49,5

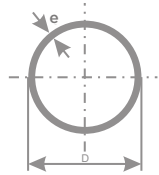



# ARMO

Armored to provide pure quality

**PAS 1075 type 3**

The pipes for transporting water with pressure

# ARMO WATER PIPES

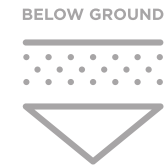

HDPE RC type 3 pipes for transporting water under pressure

We have additionally reinforced the existing PE 100 RC pipes with a protective layer, thereby expanding the polyethylene pipe family with a new member called ARMO.

ARMO pipes represent the latest generation of development of polyethylene solutions. ARMO pipes are intended for alternative pipeline installation methods and are manufactured in accordance with PAS 1075, Type 3 standard.

## TYPES OF PIPES

Armo is a double-walled tube made of innovative, highly robust PE 100 RC plastic with an extra protective layer made of polyethylene or polypropylene. This tube provides increased safety and longer life compared to traditional PE pipes, even when it comes to extreme loads such as pipe notches, grooves and point loads.

Pipes are with dimensionally added protective outer sheath of polyethylene or polypropylene. Armo tubes, as required by ISO 4065 for tubes with an outer protective layer, consist of a core tube of one-layer PE-100-RC standard dimension and a protective sheath of polypropylene or polyethylene. The minimum thickness of the sheath shall be 0.8 mm. The thickness of the sheath depends on the dimension of the pipe. Large pipes have a thicker liner due to the larger loads the pipes are designed for.

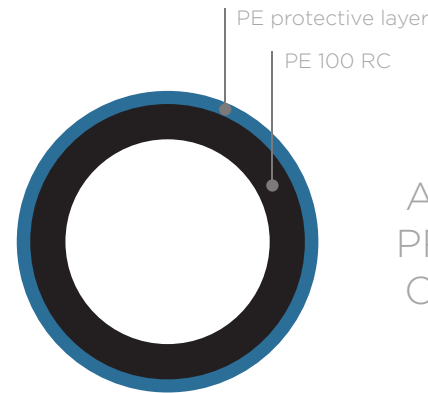
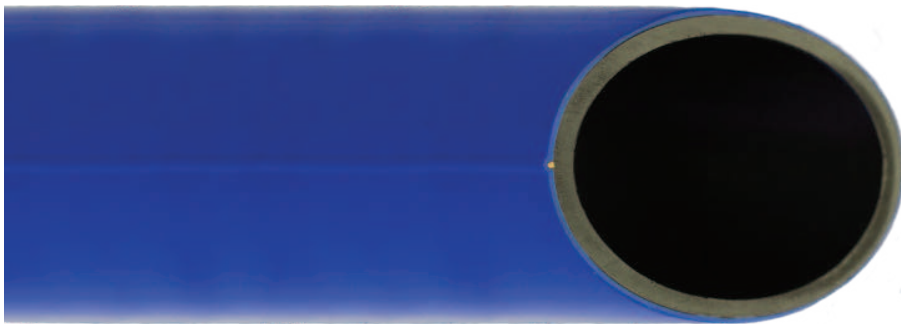

ARMO TUBES WITH PROTECTIVE LAYER OF POLYETHYLENE

ARMO TUBES WITH PROTECTIVE LAYER OF POLYPROPYLENE

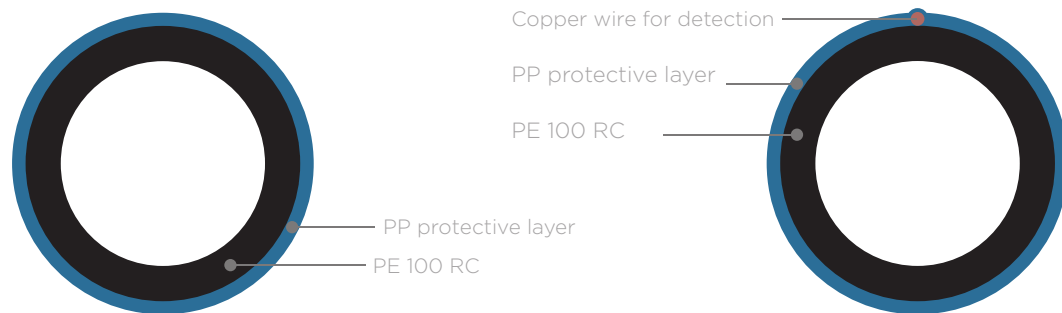



## ADVANTAGES

---

ARMO pipes have high reliability and proven performance thanks to the materials they are made of, which makes them an excellent choice, especially for pipe systems intended for civil engineering projects. Due to their high stretchability, toughness and elasticity, PESTAN ARMO pipes do not cause problems during installation and operation at low temperatures.

High resistance to hydraulic shock, fatigue and wear eliminates the need for higher nominal pressures and reduces the value of the investment. Comparisons have shown that polyethylene pipes have a higher abrasion resistance than other materials, making PE the most desirable material for pipe transport of solutes.

Excellent hydraulic characteristics (low absolute roughness) - Smooth surface and resistance to turbulent fluid flow allow for greater flow and give excellent hydraulic characteristics to ARMO pipes. ARMO pipes are resistant to a large number of chemical agents.

Due to their good weldability and elasticity, long length PE pipelines can be connected outside the trench and then laid (which reduces the required trench width) and the welds will be strong and reliable. A wide range of PE pipe fitting methods offer installers numerous installation solutions that can provide significant time and cost savings, for example PE pipes are preferred for trenchless or narrow trench installations.

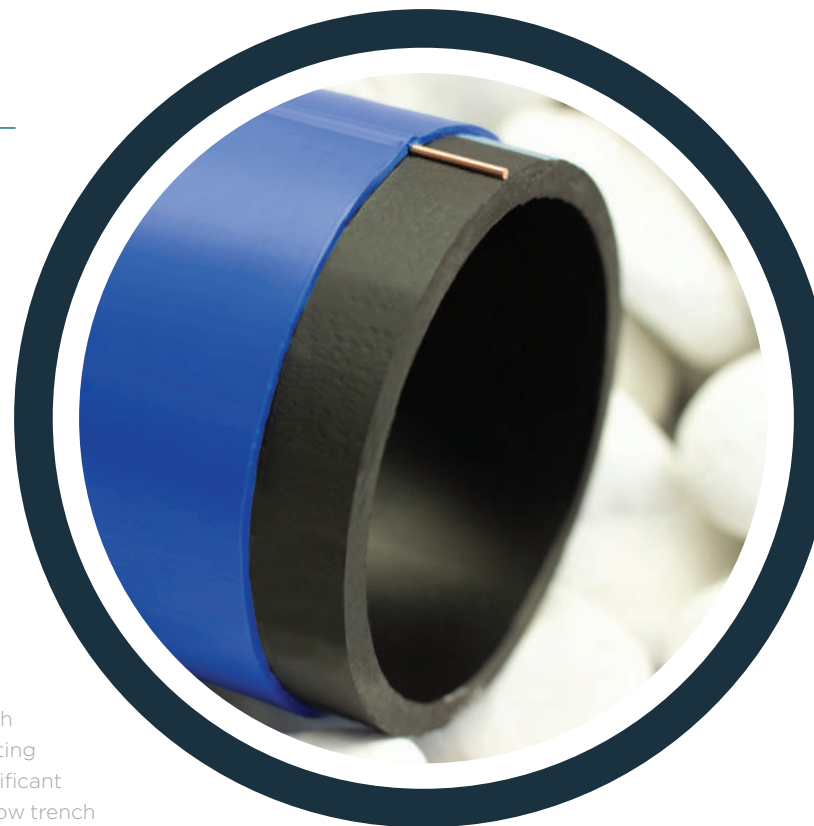

ARMO pipe look without protective layer

## TECHNIQUES OF INSTALLATION

The methods used to incorporate ARMO tubes may be unconventional because of their reinforced structure over “ordinary” HDPE tubes.

### Laying in narrow trenches

This is a modification of the classic pipe laying in a trench. Using short or long trenches, trenches that are 100 mm wider than the laying pipe are dug. Piped or pre-welded pipelines are laid in this trench. Significant savings can be achieved with a much smaller volume of excavation, less imported material (sand for bedding) and reduced work.

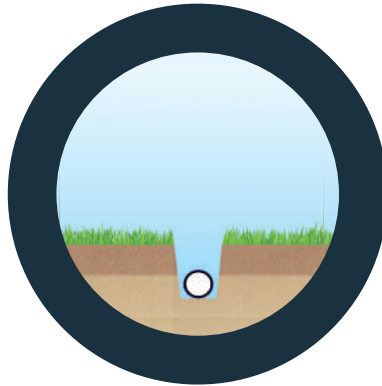

### Plowing

A technique developed on the basis of agro-cultural techniques for laying and drainage. This method is used for laying water and gas pipes on the tracks between settlements.



### Pipe bursting

This is an increasingly popular method for the rehabilitation of existing pipelines, where excavation is unacceptable. With pipe bursting, the existing pipe is destroyed and the new ARMO pipe is retracted into the resulting hole, providing replacement with the same pipe diameter, or with the help of a destroyer, the pipe diameter can be increased relative to the replaced pipe. Today's bursting hydraulic tools are capable of destroying both pipes and fittings, if the situation so requires, and with further tool adaptation even ductile and steel pipes can be destroyed.

Pipes are with dimensionally added protective outer sheath of polyethylene or polypropylene. Armo tubes, as



required by ISO 4065 for tubes with an outer protective layer, consist of a core tube of one-layer PE-100-RC standard dimension and a protective sheath of polypropylene or polyethylene. The minimum thickness of the sheath shall be 0.8 mm. The thickness of the sheath depends on the dimension of the pipe. Large pipes have a thicker liner due to the larger loads the pipes are designed for.

This method is technically demanding and requires skilled personnel and appropriate equipment. Depending on the material and condition of the old pipe, scratches and cuts may occur on the new pipe. Debris and stones cause concentrated loads during exploitation.

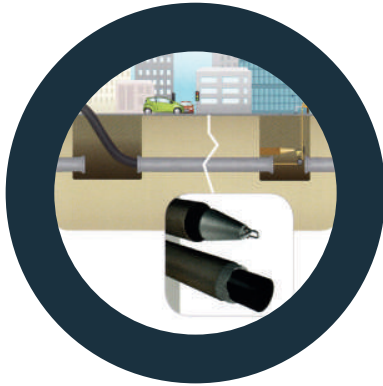

### Moling

Moling has become a commonly used non-excavation method for smaller diameter pipe fitting, and can provide significant savings over excavation pipe fitting. Excavation is done only for entry and exit pits, so moling is ideal for underpasses and expensive sidewalks or sidewalks, gardens and gardens where excavation would disrupt land and plants. The moling tool is a percussion tool with a pneumatic motor, which drills a hole (tunnel) and in most cases pulls a new PE tube. Experienced contractors are required to perform this installation technique so as not to exceed the permissible stresses of a pre-welded pipeline or coil when drawn.

### Directional drilling

This technique also became a conventional one and is used as an installation method for polyethylene pipes and is used for underpasses, railways and rivers, in places where excavation is difficult, expensive or impossible.

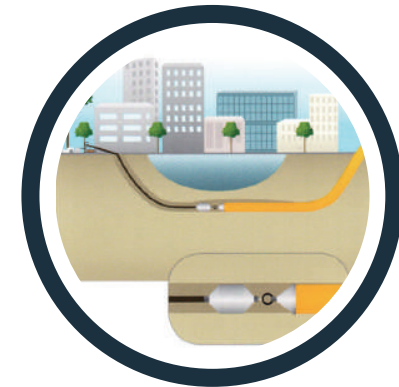

### Slip-lining

Inserting smaller diameter ARMO pipes, slip-lining, into an existing pipeline is one of many techniques without excavation for rehabilitation - rehabilitation of old pipelines. With slip-lining a reduction in pipe diameter is inevitable, though this can be reduced to a minimum by thoroughly cleaning the old pipeline and choosing the largest possible pipe diameter for insertion. The smaller diameter is offset by the improved hydraulic performance of polyethylene, and in some cases we even have the higher throughput of the new pipeline.



## PIPE DETECTION

For the detection of the ARMO pipeline, the simplest and most economical method is to place in the trench a tube containing in its structure a marker, a copper wire for monitoring - detection. A marker wire is placed between the center and outer layers of the pipe.

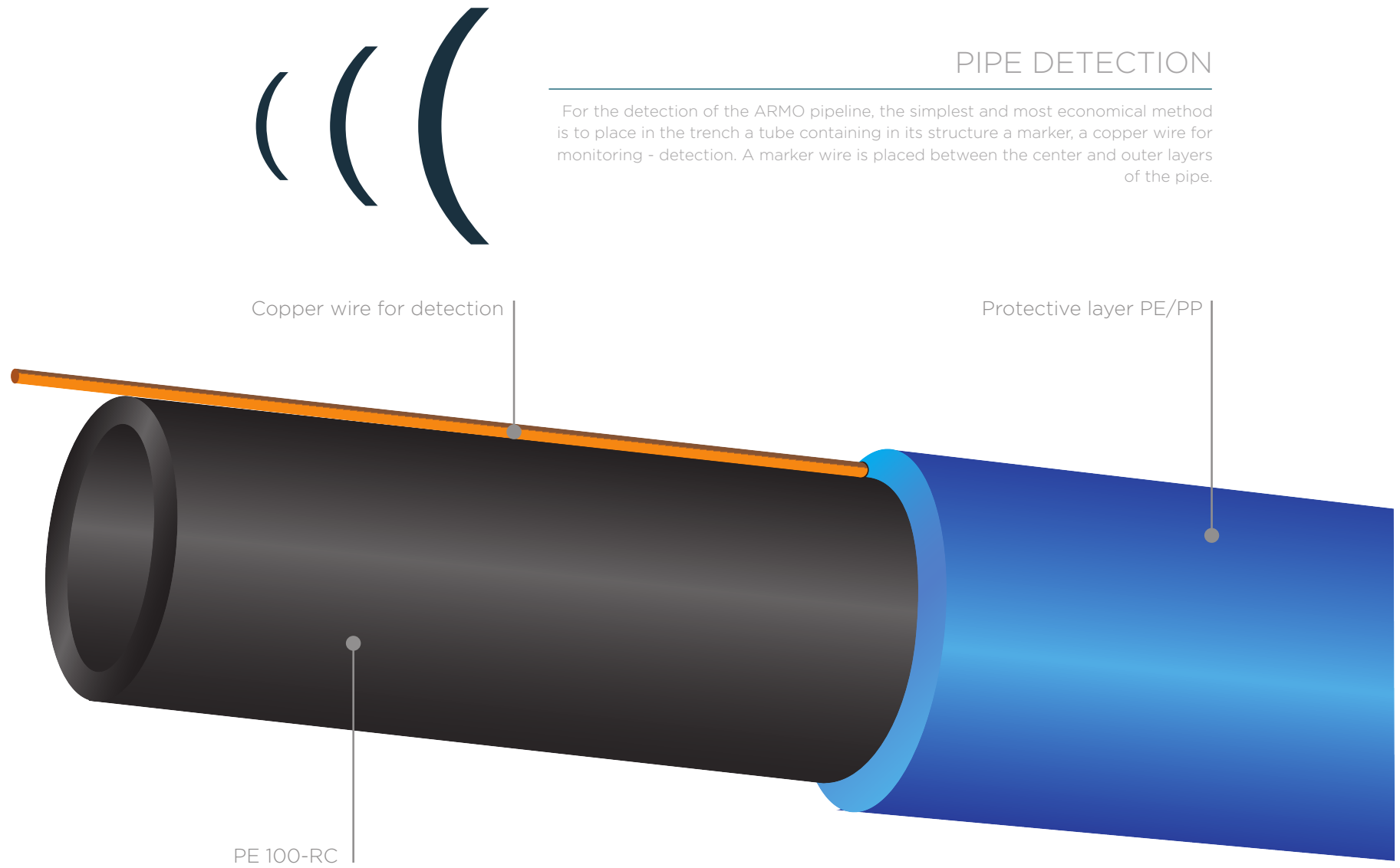

## PIPE CONNECTION

These pipes can be connected with conventional welding (like other PE pipes), with the difference to pay attention if the pipes have copper wire in their structure. Pipes and fittings can be connected by welding the ends with standard techniques for joining PE pipes. Pestan Armo pipes are compatible with the fittings of leading manufacturers and do not require special material for installation which is their biggest advantage. Joining methods of Armo tubes are electrofusion welding, butt welding, and mechanical joining.

During electrofusion pipe welding, it is mandatory to remove the protective layer, whether made of PE or PP. The minimum length of removal of an additional protective layer from PP or PE, for a given pipe diameter, should be according to the dimensions shown in the table 1.

Armo pipes are compatible with fusion welding connectors of all worldwide leader manufacturers.

If ARMO pipes, which have an integrated copper wire for detection, are connected by electro-fusion, the copper wire must be moved to the side after removal of the protective layer, until the pipes are connected and then the ends of the copper wire are connected by an electric coupler. After that, it is imperative to protect the junction point of the ARMO pipe with a heat-shrink film and/or a butyl rubber-based self-bonding strip (to prevent corrosion and electrical insulation on pipes and metal parts).

\*table No 1

**DN [mm]**

110	90
125	95
140	105
160	110
180	115
200	120
225	125
250	135
280	150
315	160
355	160
400	170
450	180
500	190
560	200
630	220

**Length of removal of the protective layer**

The butt welding of the pipes **without copper wire** for detection is done in the following steps:

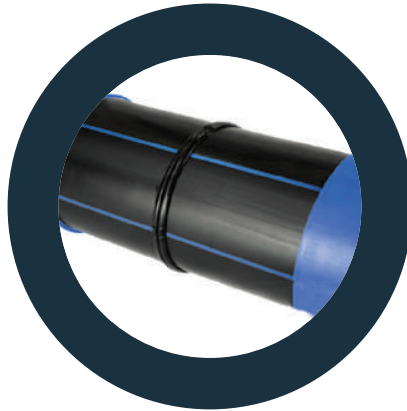

- If the **outer layer is made of polyethylene**, the welding is carried out without removing of the protective layer.
- If the **outer layer is polypropylene**, it is necessary to peel the outer layer according to Table 1 and connect the pipes. Finally, the junction point of the ARMO pipe is insulated with a heat shrink film and / or butyl rubber based self-adhesive tape.

The butt welding of the tube **with the copper wire** for detection is done in the following steps:

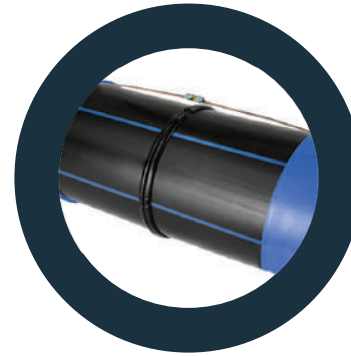

- Peel the outer PP layer of the pipe in accordance with Table 1 with care not to damage the copper wire and the middle layer.
- Move copper wire to the side (usually “pulled” backwards) and the middle layer will be bonded with the butt welding machine. After that, the two ends of the copper wire are connected by an electrical connector.
- Finally, the junction point of the ARMO middle layer and the copper wire junction is insulated with a heat shrink film and / or butyl rubber based self-adhesive tape (to prevent corrosion and electrical insulation on pipes and metal parts).



DN [mm]	SDR 41	SDR 33	SDR 26	SDR 21	SDR 17	SDR 13.6	SDR 11	SDR 9	SDR 7.4	SDR 6
	PN 4	PN 5	PN 6	PN 8	PN 10	PN 12.5	PN 16	PN 20	PN 25	PN 32
	e <sub>min</sub> [mm]	e <sub>min</sub> [mm]	e <sub>min</sub> [mm]	e <sub>min</sub> [mm]	e <sub>min</sub> [mm]	e <sub>min</sub> [mm]	e <sub>min</sub> [mm]	e <sub>min</sub> [mm]	e <sub>min</sub> [mm]	e <sub>min</sub> [mm]
110			4.2 + APL*	5.3 + APL*	6.6 + APL*	8.1 + APL*	10.0 + APL*	12.3 + APL*	15.1 + APL*	18.3 + APL*
125			4.8 + APL*	6.0 + APL*	7.4 + APL*	9.2 + APL*	11.4 + APL*	14.0 + APL*	17.1 + APL*	20.8 + APL*
140			5.4 + APL*	6.7 + APL*	8.3 + APL*	10.3 + APL*	12.7 + APL*	15.7 + APL*	19.2 + APL*	23.3 + APL*
160			6.2 + APL*	7.7 + APL*	9.5 + APL*	11.8 + APL*	14.6 + APL*	17.9 + APL*	21.9 + APL*	26.6 + APL*
180			6.9 + APL*	8.6 + APL*	10.7 + APL*	13.3 + APL*	16.4 + APL*	20.1 + APL*	24.6 + APL*	29.9 + APL*
200			7.7 + APL*	9.6 + APL*	11.9 + APL*	14.7 + APL*	18.2 + APL*	22.4 + APL*	27.4 + APL*	33.2 + APL*
225			8.6 + APL*	10.8 + APL*	13.4 + APL*	16.6 + APL*	20.5 + APL*	25.2 + APL*	30.8 + APL*	37.4 + APL*
250			9.6 + APL*	11.9 + APL*	14.8 + APL*	18.4 + APL*	22.7 + APL*	27.9 + APL*	34.2 + APL*	41.5 + APL*
280			10.7 + APL*	13.4 + APL*	16.6 + APL*	20.6 + APL*	25.4 + APL*	31.3 + APL*	38.3 + APL*	46.5 + APL*
315	7.7 + APL*	9.7 + APL*	12.1 + APL*	15.0 + APL*	18.7 + APL*	23.2 + APL*	28.6 + APL*	35.2 + APL*	43.1 + APL*	52.3 + APL*
355	8.7 + APL*	10.9 + APL*	13.6 + APL*	16.9 + APL*	21.1 + APL*	26.1 + APL*	32.2 + APL*	39.7 + APL*	48.5 + APL*	59.0 + APL*
400	9.8 + APL*	12.3 + APL*	15.3 + APL*	19.1 + APL*	23.7 + APL*	29.4 + APL*	36.3 + APL*	44.7 + APL*	54.7 + APL*	66.5 + APL*
450	11.0 + APL*	13.8 + APL*	17.2 + APL*	21.5 + APL*	26.7 + APL*	33.1 + APL*	40.9 + APL*		61.5 + APL*	
500	12.3 + APL*	15.3 + APL*	19.1 + APL*	23.9 + APL*	29.7 + APL*	36.8 + APL*	45.4 + APL*			
560	13.7 + APL*	17.2 + APL*	21.4 + APL*	26.7 + APL*	33.2 + APL*	41.2 + APL*	50.8 + APL*			
630	15.4 + APL*	19.3 + APL*	24.1 + APL*	30.0 + APL*	37.4 + APL*	46.3 + APL*	57.2 + APL*			

\*APL - additional protective layer (PP/PE), minimum 0.8 mm, depending on pipe dimensions, conditions of application and type of the project.





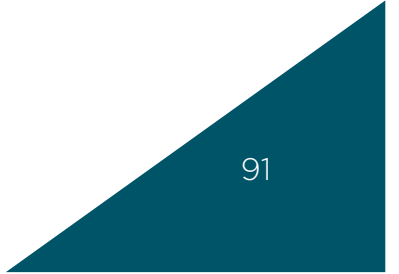
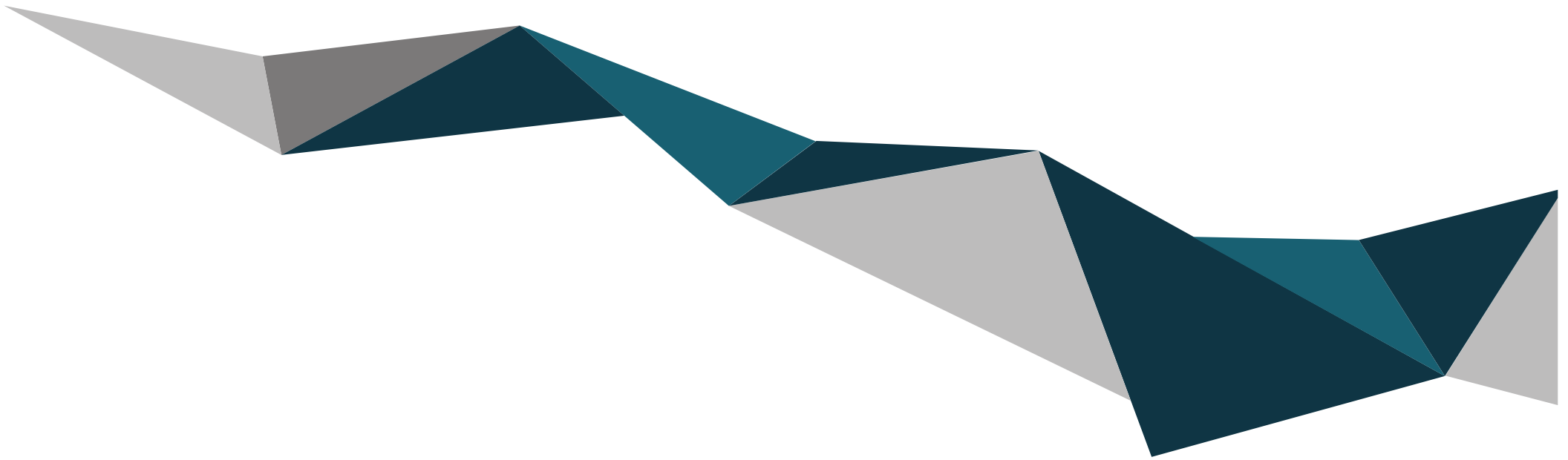

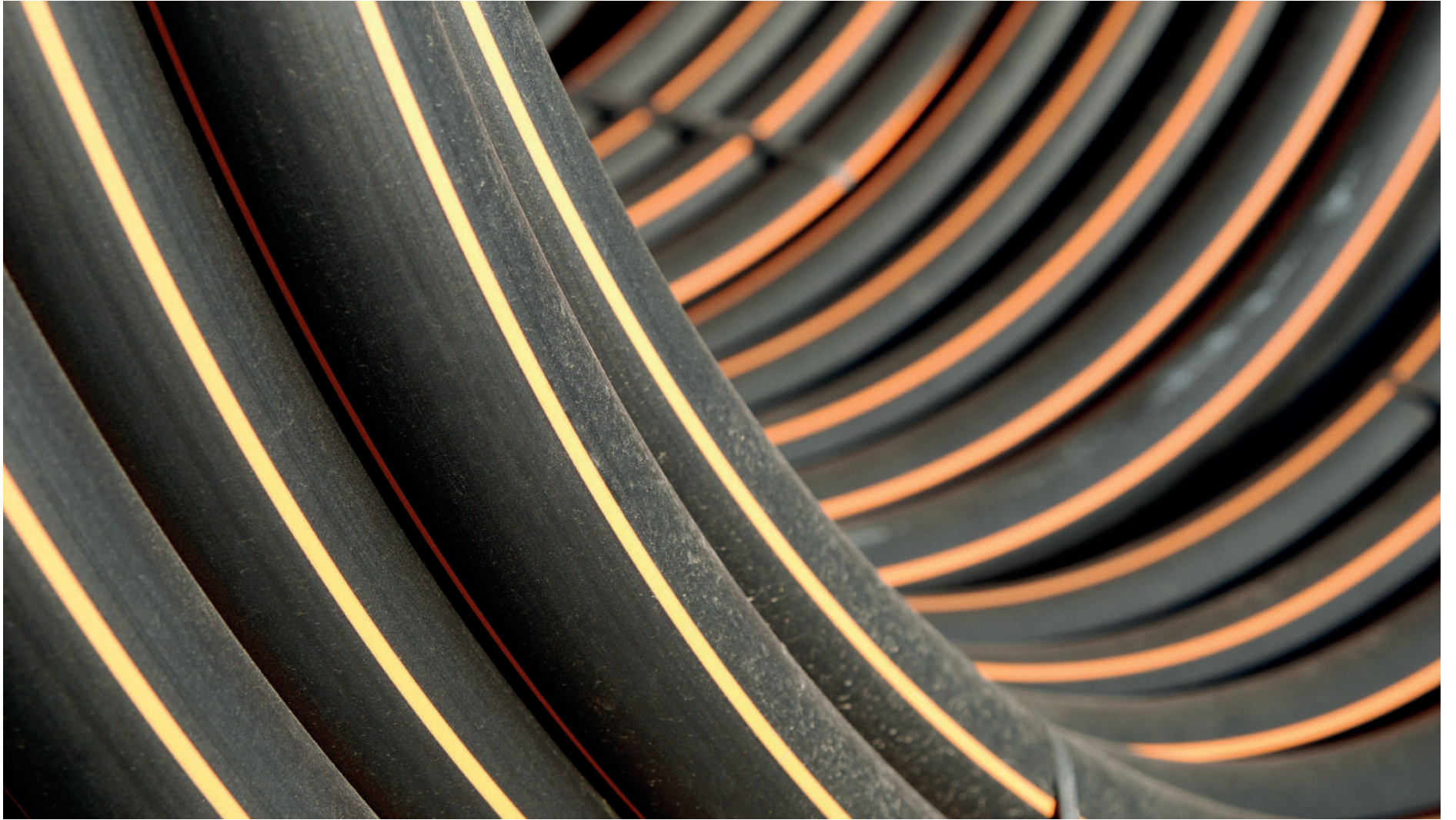

# HDPE GAS PIPES

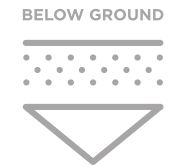

Polyethylene gas pipes

The need for PE pipes is increasing throughout the whole world. Their small weight allows easy handling, and simple, swift and reliable assembling. They are flexible and can be delivered in the rollers of 200m. They are extremely resistant to chemical, therefore they can be easily placed into the aggressive ground. They have a very high impact resistance even at very low temperatures, especially if made of network like polyethylene. These pipes do not corrode and have a lifespan of over 50 years.

**Pipes are entirely in accordance with SRPS-EN1555, ISO 4437 (DIN8074).**

## PREFERENCES

Pipes PE80 - products are available in black with yellow longitudinal lines.

The material used in the manufacture of the gas pipe is approved by the European Union for this application.

Wall thickness for both PE80 and PE100 gas pipes is the same, but with the difference in working pressure is 1, 4, 6, 6, 2 and 10 bar.

## TECHNOLOGY

The pipes are entirely in accordance with EN 1555, ISO 4437 (DIN 8074) standards. PEŠTAN uses materials made by the world known companies, which have been checked and approved by its own laboratory. The production itself is monitored and controlled by the contemporary scanners. At the same time PEŠTAN controls the quality of its products in the independent international laboratories.

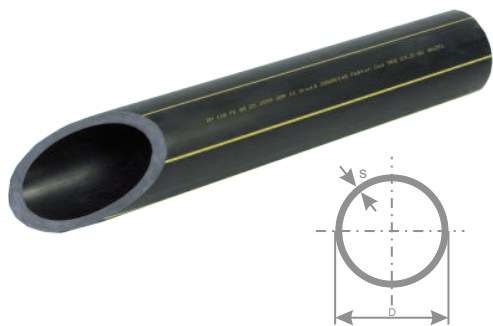

D(MM)	CODE	SDR17 (S-8) PN1		SDR11 (S-5) PN4		
		S	KG/M	CODE	S	KG/M
20	11600001	2.3	0.133	11600101	3	0.163
25	11600002	2.3	0.171	11600102	3	0.211
32	11600003	2.3	0.224	11600103	3	0.279
40	11600004	2.3	0.285	11600104	3.7	0.43
50	11600005	2.9	0.44	11205105	4.6	0.666
63	11600006	3.6	0.688	11600106	5.8	1.05
75	11600007	4.3	0.976	11600107	6.8	1.47
90	11600008	5.2	1.41	11600108	8.2	2.12
110	11600009	6.3	2.08	11600109	10	3.14
125	11600010	7.1	2.66	11600110	11.4	4.08
140	11600011	8	3.34	11600111	12.7	5.08
160	11600012	9.1	4.35	11600112	14.6	6.67
180	11600013	10.3	5.53	11600113	16.4	8.42
200	11600014	11.4	6.79	11600114	18.2	10.4
225	11600015	12.8	8.55	11600115	20.5	13.1
250	11600016	14.2	10.6	11600116	22.7	16.2
280	11600017	15.9	13.2	11600117	25.4	20.3
315	11600018	17.9	16.7	11600118	28.6	25.6
355	11600019	20.2	21.3	11600119	32.3	32.6
400	11600020	22.8	27	11600120	36.4	41.4
450	11600021	25.6	34.23	11600121	41	52.83
500	11600022	28.5	42.34	11600122	45.5	65.15
560	11600023	31.9	53.08	11600123	51	81.78
630	11600024	35.8	67.02	11600124	57.3	103.38

## FITTING

Peštan is able to offer complete program of welded accessories made in all diameters and in all working pressures. Also other working pressures are available by the request.

# HDPE PE-80

SDR11 (S-5) PN10				SDR17,6 (S-8.3) PN6				SDR17 (S-8) PN6			
D(MM)	CODE	S	KG/M	D(MM)	CODE	S	KG/M	D(MM)	CODE	S	KG/M
16	11700500	3.0c	0.126	16	11700000	2.3c	/	16	11700260	2.3c	/
20	11700501	3.0c	0.165	20	11700001	2.3c	0,133	20	11700261	2.3c	0,133
25	11700502	3.0c	0.213	25	11700002	2.3c	0,171	25	11700262	2.3c	0,171
32	11700503	3.0	0.281	32	11700003	2.3c	0,224	32	11700263	2.3c	0,224
40	11700504	3.7	0.434	40	11700004	2.3	0,285	40	11700264	2.4	0,295
50	11700505	4.6	0.672	50	11700005	2.9	0,440	50	11700265	3.0	0,454
63	11700506	5.8	1.062	63	11700006	3.6	0,688	63	11700266	3.8	0,722
75	11700507	6.8	1.483	75	11700007	4.3	0,976	75	11700267	4.5	1,02
90	11700508	8.2	2.149	90	11700008	5.2	1,41	90	11700268	5.4	1,466
110	11700509	10.0	3.187	110	11700009	6.3	2,08	110	11700269	6.6	2,182
125	11700613	11.4	4.134	125	11700112	7.1	2,66	125	10700342	7.4	2,783
140	11700623	12.7	5.153	140	11700123	8.0	3,34	140	11700352	8.3	3,494
160	11700633	14.6	6.762	160	11700133	9.1	4,35	160	11700362	9.5	4,56
180	11700643	16.4	8.541	180	11700142	10.3	5,53	180	11700372	10,7	5,768
200	11700653	18.2	10.539	200	11700153	11.4	6,79	200	11700382	11,9	7,118
225	11700663	20.5	13.342	225	11700163	12.8	8,55	225	11700392	13,4	9,028
250	11700673	22.7	16.406	250	11700173	14.2	10,60	250	11700402	14,8	11,063
280	11700683	25.4	20.036	280	11700183	15.9	13,20	280	11700412	16,6	13,899
315	11700693	28.6	26.036	315	11700193	17.9	16,70	315	11700422	18,7	17,601
355	11700703	32.2	33.141	355	11700203	20.2	21,30	355	11700432	21,1	22,403
400	11700713	36.3	42.057	400	11700213	22.8	27,00	400	11700442	23,7	28,312
450	11700723	40.9	53.132	450	11700223	25.6	34,23	450	11700452	26,7	35,869
500	11700733	45.4	65.684	500	11700233	28.4	42,34	500	11700462	29,7	44,32
560	11700743	50.8	82.273	560	11700243	31.9	53,08	560	11700472	33,2	55,523
630	11700753	57.2	104.22	630	11700253	35.8	67,02	630	11700482	37,4	70,322

## PREFERENCES

PE100 pipes are made in black color with orange longitudinal lines.

## PACKAGING & TRANSPORT

When transporting and storing the pipes, they must not be dragged in the dirt or on sharp objects; also they must not come in contact with mineral oils, emollients or various coatings.

The pipes should be placed on the flat surface. The can be stored for the period of up to two years in the open.

# HDPE PE-100

Registration control number: DVGW DG8106BR0083 DG8111BR0084







SEWAGE





# PVC PIPES - 3P

---



Production program Pestan PVC pipes for home system sewage-3p pipes- represents the pipes made of supreme quality polivynil chloride PVC-U in diameters Ø32 do Ø160.

Also these pipes are produced in lengths of 250 mm, 500 mm, 1000 mm, 2000 mm, 3000 mm, 4000 mm.

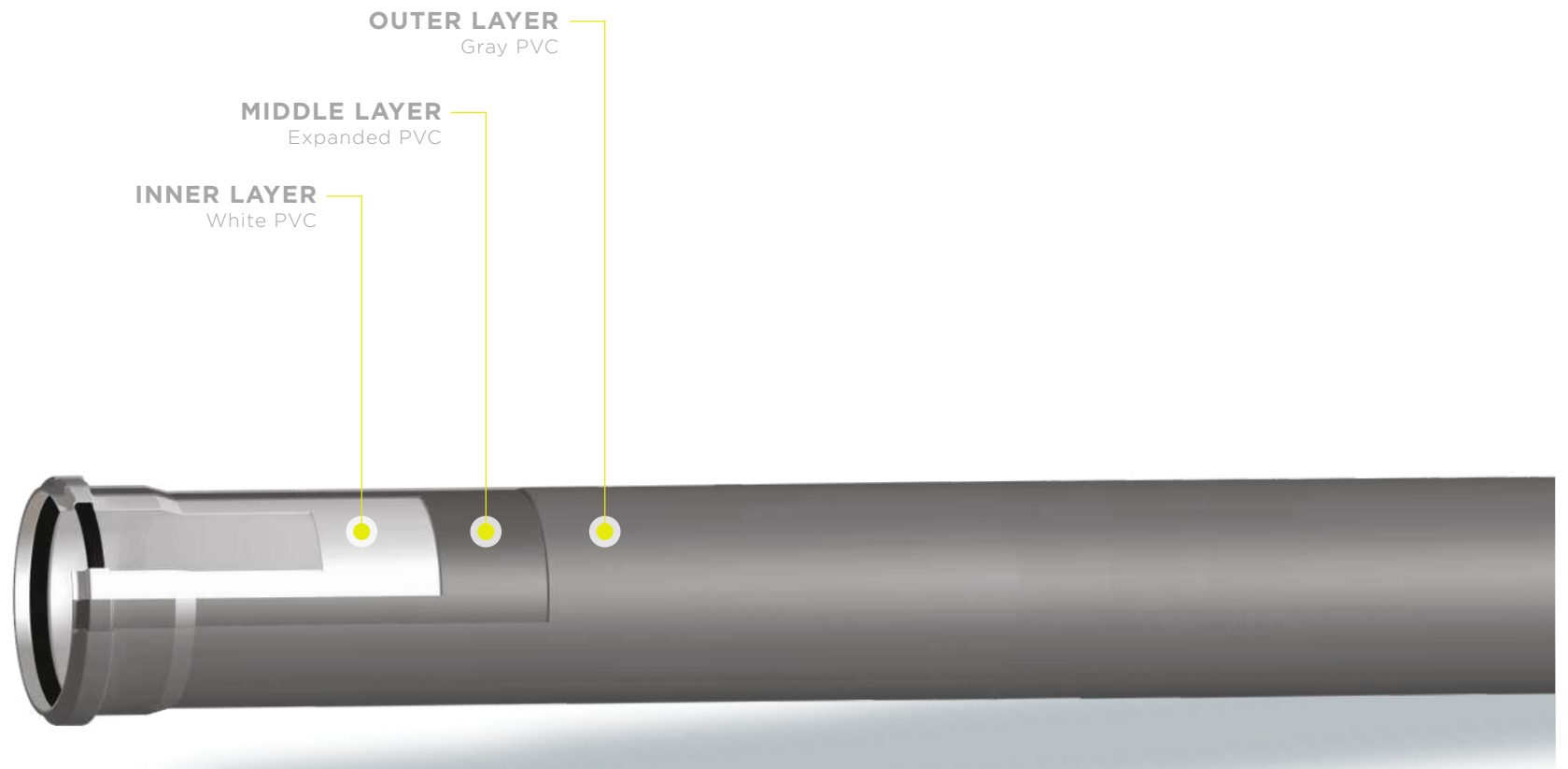

Pešťan PVC pipes are produced as three layered with inner white layer which is very smooth thanks to special technology and because of that the sedimenting on inner layers is decreased. White color makes easier inspections of pipeline.

It should be highlighted that using special technology these pipes manage to reduce noise level more than regular PVC pipes during the flow.

Next to the standard sizes Pestan produces also 3P pipe diameter 110 with an increased wall thickness (3.2 mm) - PEŠTAN PREMIUM PIPE ULTRA

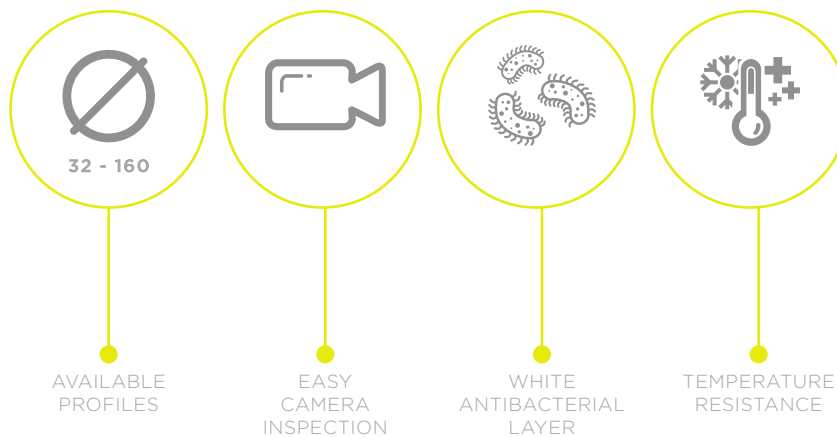

**KG PIPE SDR51 SN2**

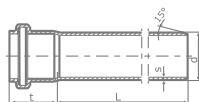

10100004	32	1,8	41
10100024	40	1,8	47
10100044	50	1,8	48
10100104	75	1,8	55
10100204	110	2,2	61
10100224	125	2,5	72



# HT (PP) PIPES



& fittings for domestic & street sewage systems

**The pipes for domestic sewerage systems together with the appropriate coupling sleeves are intended to be used for the removal of all kinds of waste water.**

Assembly of the pipeline is extremely easy, pipes are connected to one another with fittings while complete seal is achieved with use of rubber bands. Maximum temperature of application is +90 °C. Pipes are resistant to salt water, alcohol, acids, alkalis, sulphates, aggressive gas and all kinds of detergents. On the other hand, they cannot be used for the transport of water which contains high percentage of benzene, benzine (petrol) or acetone.

## Advantages & owner benefits

- Very light material
- Simple and easy way of both transport and manipulation
- Fast and cheap assembling
- Pipe connections are resistant to water and other type of fluids
- They are resistant to corrosion in alkaline, acid or aggressive environment
- They are fine electrical insulator, and also resistant to mechanical impact
- Guaranteed life time of more than 50 years
- Practically no costs of pipeline maintenance
- Connection with muffs and gaskets made of EPDM or rubber (EN 681)
- SRPS-EN 1451



## Acoustic insulation

According to DIN 4109 noise generated from the pipeline, built-in sound-protected areas should not exceed 35dB (A). At the same time, the norm VDI 4100 guideline shows that the noise should not exceed 30dB (A). From the above mentioned reasons, Pešťan and its HT PP pipes were put on testing at the renowned Institute in Stuttgart, where is obtained confirmation of our quality. According to studies, Pešťan HT PP pipes and related fittings can be classified into LEVEL II sound insulation with results of 24dB (A), obtained in the tests (Test Report P-BA 95/2016). Test was performed on standard commercial collars.

	44	47	51	60
Airborne sound pressure level $L_{pA}$ [dB(A)] according to EN 14366 in the basement test-room UG front	49	52	52	55
Structure-borne sound characteristic level $L_{sA}$ [dB(A)] according to EN 14366 in the basement test-room UG rear	24	30	24	31

TEST WAS PERFORMED ON STANDARD COMMERCIAL COLLARS.



According to VDI 4100, there are three levels of sound insulation, depending on the purpose of the facility in which the pipes are installed:

- Level I sound insulation - requirements according to DIN 4109 corresponding to 30dB (A)
- Level II sound insulation - a higher level of sound insulation corresponds to 25dB (A)
- Level III sound insulation - the highest level of sound insulation corresponds to 20dB (A)

Test was performed on standard commercial collars.



## VDI levels of sound insulation and classification:

- Level I sound insulation - family houses;
- Level II sound insulation - apartment buildings, residential and commercial buildings with few floors;
- Level III sound insulation - hotels, hospitals, libraries, reading rooms, residential complexes...



On family houses

**Sound insulation level I or on agreement**



Apartment buildings, residential and office buildings, comfort apartments

**Sound insulation level II or higher**



Hotels, hospitals, residential complexes

**Sound insulation level III enhanced agreements**



## HT (PP) pipes & fittings

Product range from Ø32 up to Ø160



ITEM DESCRIPTION	PICTURE	CODE	D	D1	D2	S
HTEM PIPE SDR41						
		10200004	32	32,3	38,6	1,8
		10200024	40	40,3	49,6	1,8
		10200044	50	50,3	59,6	1,8
		10200104	75	75,3	84,5	1,9
		10200154	90	90,4	99,5	2,2
		10200204	110	110,3	120,5	2,7
		10200224	125	125,3	137,5	3,1
		10200244	160	160,3	174,3	3,9

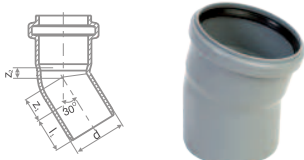
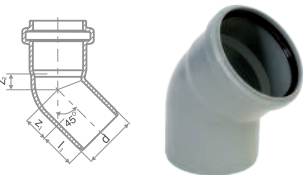
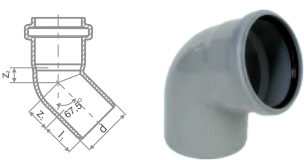
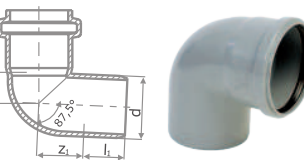

ITEM DESCRIPTION	PICTURE	CODE	D	D1	D2	S
HTEM PIPE SDR41						
		19906500	32	32,3	38,6	1,8
		19906511	40	40,3	49,6	1,8
		19906521	50	50,3	59,6	1,8
		19906531	75	75,3	84,5	1,9
		19906642	90	90,4	99,5	2,2
		19906541	110	110,3	120,5	2,7
		19906551	125	125,3	137,5	3,1
		19909561	160	160,3	174,3	3,9

ITEM DESCRIPTION	PICTURE	CODE	D	Z1	Z2	L1MIN
<b>HTB BEND 15°</b>						
	10200300	30	3	5	39	
	10200301	40	4	7	44	
	10200302	50	5	9	46	
	10200304	75	7	11	51	
	10200329	90	5.62	10.33	55	
	10200308	110	9	14	58	
	10200309	125	10	14	82	
<b>HTB BEND 30°</b>						
	10200500	32	8	13	39	
	10200501	40	14	14	44	
	10200502	50	9	12	46	
	10200529	90	11.44	16.44	55	
	10200508	110	17	21	58	
	10200509	125	10	15	15	
	10200510	160	29	23	23	
<b>HTB BEND 45°</b>						
	10200600	32	9	12	42	
	10200601	40	10	14	44	
	10200602	50	12	16	46	
	10200604	75	18	21	51	
	10200637	90	47	23	37	
	10200608	110	25	29	58	
	10200635	125	28	33	64	
	10200610	160	42	36	94	
<b>HTB BEND 67.5°</b>						
	10200700	32	13	16	42	
	10200701	40	16	19	44	
	10200702	50	19	23	46	
	10200704	75	28	32	51	
	10200723	90	28.53	34.45	55	
	10200708	110	40	46	58	
	10200709	125	45	50	82	
	10200710	160	64	58	94	
<b>HTB BEND 87.5°</b>						
	10200800	32	19	23	42	
	10200801	40	23	26	44	
	10200802	50	28	31	46	
	10200804	75	40	43	51	
	10200837	90	49	46	49	
	10200808	110	57	57	58	
	10200809	125	65	65	64	
	10200810	160	89	83	94	

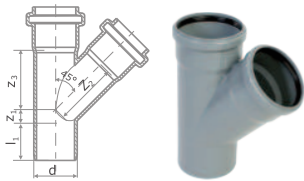
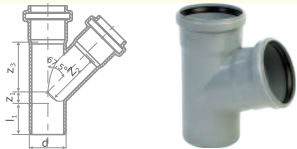
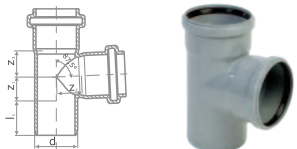
ITEM DESCRIPTION	PICTURE	CODE	D	Z1	Z2	Z3	L1MIN
<b>HTEA BRANCH 45°</b>							
	10200900	32/32	9	40	40	42	
	10200901	40/32	5	46	44	44	
	10200902	40/40	10	49	49	44	
	10200903	50/32	-1	53	49	46	
	10200904	50/40	5	56	54	46	
	10200905	50/50	12	61	61	46	
	10200912	75/50	-1	79	74	51	
	10200914	75/75	18	91	91	51	
	10201073	90/50	9.64	98.01	90.34	55	
	10200986	90/90	17	110	161	56	
	10200938	110/50	-17	104	91	58	
	10200940	110/75	1	116	109	58	
	10200944	110/110	25	134	134	58	
	10200953	125/110	18	144	141	64	
	10200954	125/125	28	152	152	64	
	10200963	160/110	1	168	159	81	
10200965	160/160	36	194	194	81		
<b>HTEA BRANCH 67.5°</b>							
	10201000	32/32	13	27	27	42	
	10201002	40/40	16	33	33	44	
	10201005	50/50	19	40	40	46	
	10201038	110/50	9	72	52	58	
	10201044	110/110	40	85	85	58	
<b>HTEA BRANCH 87.5°</b>							
	10201100	32/32	19	21	21	42	
	10201101	40/32	19	25	21	44	
	10201102	40/40	23	25	25	44	
	10201103	50/32	19	30	21	46	
	10201104	50/40	23	30	25	46	
	10201105	50/50	28	30	30	46	
	10201112	75/50	27	43	31	51	
	10201114	75/75	40	43	43	51	
	10202186	90/40	16.91	93.05	83.37	55	
	10202187	90/50	23.06	55.1	36.57	55	
	10201196	90/90	43.13	56.64	56.64	56	
	10201198	110/40	20.40	56	30.5	58	
	10201138	110/50	28	60	32	58	
	10201140	110/75	40	60	45	58	
	10201144	110/110	57	62	62	58	
	10201153	125/110	58	69	63	64	
	10201154	125/125	65	70	70	64	
	10201164	160/125	66	87	71	81	
10201165	160/160	83	89	89	81		

ITEM DESCRIPTION	PICTURE	CODE	D	Z1	Z2	Z3	L1MIN
<b>HTDA DOUBLE BRANCH 45°</b>							
	10201505	50/50/50	12	61	61	46	
	10201538	50/110/50	-17	104	91	58	
	10201544	110/110/110	25	134	134	58	
<b>HTDA DOUBLE BRANCH 67,5°</b>							
	10201605	50/50/50	19	40	40	46	
	10201638	50/110/50	9	72	52	58	
	10201644	110/110/110	40	85	85	58	
<b>HTDA DOUBLE BRANCH 87,5°</b>							
	10201738	50/110/50	28	30	30	46	
	10201744	110/110/110	28	60	32	58	
<b>HTRE INSPECTION PIPE</b>							
	10201402	50	32	30	46		
	10201404	75	48	43	51		
	10201408	110	58	62	58		
	10201409	125	58	62	64		

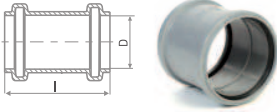
ITEM DESCRIPTION	PICTURE	CODE	D	Z1	I
<b>HTU DOUBLE SOCKET</b>					
	10202300	32	94		
	10202301	40	103		
	10202302	50	103		
	10202304	75	109		
	10202339	90	104		
	10202308	110	122		
	10202309	125	138		
<b>HTU SLIP COUPLER</b>					
	10202400	32	94		
	10202401	40	103		
	10202402	50	103		
	10202404	75	109		
	10202408	110	122		
	10202409	125	138		
<b>HTR EXCENTRIC REDUCER</b>					
	10201200	40/32	10	44	
	10201201	50/32	16	46	
	10201202	50/40	12	46	
	10201208	75/50	20	51	
	10201230	110/50	40	58	
	10201232	110/75	26	58	
	10201244	125/110	15	64	
	10201253	160/110	34	81	
10201254	160/125	27	81		
<b>HTM END CAP</b>					
	10202200	32			
	10202201	40			
	10202202	50			
	10202204	75			
	10202208	110			
	10202209	125			
	10202210	160			
10202211	200				
<b>HT VENTILATION CAP</b>					
	10202705	50	106	94	
	10202700	75	143	119	
	10202701	110	168	110	
	10202703	160	253	150	

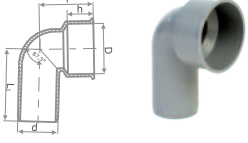
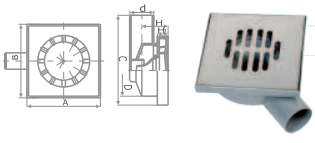
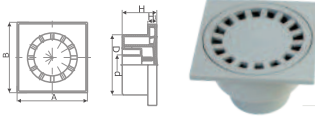
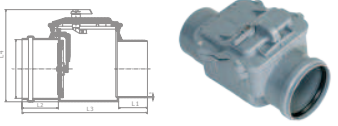
ITEM DESCRIPTION	PICTURE	CODE	D	D	H	L	L1			
<b>HTSW FLOOR WASTE GULLE</b>										
		10202104	50	50,6	32,8	71	80			
<b>HTSW FLOOR WASTE GULLE</b>										
		10202101	32	46	26	51	61			
		10202103	40	46	26	51	75			
<b>HTSW FLOOR WASTE GULLEY TYPE 1</b>										
		10202100	32	53,7	26	51	61			
		10202102	40	53,7	26	51	75			
ITEM DESCRIPTION	PICTURE	CODE (METAL GRID)	CODE (PLASTIC GRID)	D	A	B	C	D	H	H1
<b>HTSW FLOOR WASTE GULLEY</b>										
		10299910	10299000	50	150	150	192	139,5	46,5	12,5
		10299920	10299002	75	150	150	195	160	56,5	12,5
ITEM DESCRIPTION	PICTURE	CODE (METAL GRID)	CODE (PLASTIC GRID)	D	A	B	C	D	H	H1
<b>HTSW FLOOR WASTE GULLEY TYPE 2</b>										
		10299911	10299001	50	150	150		125	60	12,5
		10299921	10299003	75	200	200		160	130	9
		-	10299005	110	200	200		160	130	9
		-	10299010	110	250	250		200	85	12
ITEM DESCRIPTION	PICTURE	CODE	D	S	L1	L2	L3	L4		
<b>NON-RETURN VALVE</b>										
		10202500	50	2,2	50	40	197	98		
		10202501	75	2,5	70	54	265	139		
		10202502	110	4,0	64	64	320	189		
		10202503	125	4,0	68	65	318	226		
		10202504	160	4,0	68	103	350	248		

CODE	ITEM DESCRIPTION	PICTURE	Size D (mm)	L (mm)	L1 (mm)	W (mm)	Std Pck
------	------------------	---------	-------------	--------	---------	--------	---------

40006635

HPPP P TRAP, GREY, DN110 MM

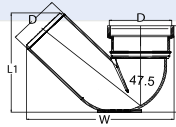

110

167

269

176

10

CODE	ITEM DESCRIPTION	PICTURE	Size D (mm)	d (mm)	d1 (mm)	h (mm)	H1 (mm)	W	Std Pck
------	------------------	---------	-------------	--------	---------	--------	---------	---	---------

40006637

HPPP FLOOR TRAP, GREY, DN 110/DN75/  
DN50

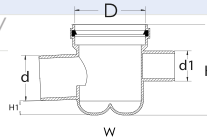

110

75

50

141

50

213

10

CODE	ITEM DESCRIPTION	PICTURE	Size D (mm)	d (mm)	d1 (mm)	h (mm)	H1 (mm)	W	Std Pck
------	------------------	---------	-------------	--------	---------	--------	---------	---	---------

40006638

HPPP DEEP FLOOR TRAP, GREY, DN110/  
DN75/DN50

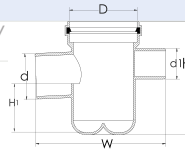

110

75

50

175

72

213

10





**12dB (A)**  
Sound Insulation  
Level III

Let  
the **silence**  
be the only  
thing you hear

**S·LINE**



# S-LINE



Silent pipes and fittings Ø32 - Ø250

Provides reduction in noise and vibrations up to level of 12dB

## S LINE SILENT SEWAGE SYSTEM

**The pipes for domestic sewerage systems together with the appropriate coupling sleeves are intended to be used for the removal of all kinds of waste water.**

Peštan silent piping system is a promoted version of Peštan HTPP home sewage system and it is specially designed for installation in places where sound insulation is taken into account.

\* In case of special request we offer diameters of 160 (200, 250, 315, 400 i 500)

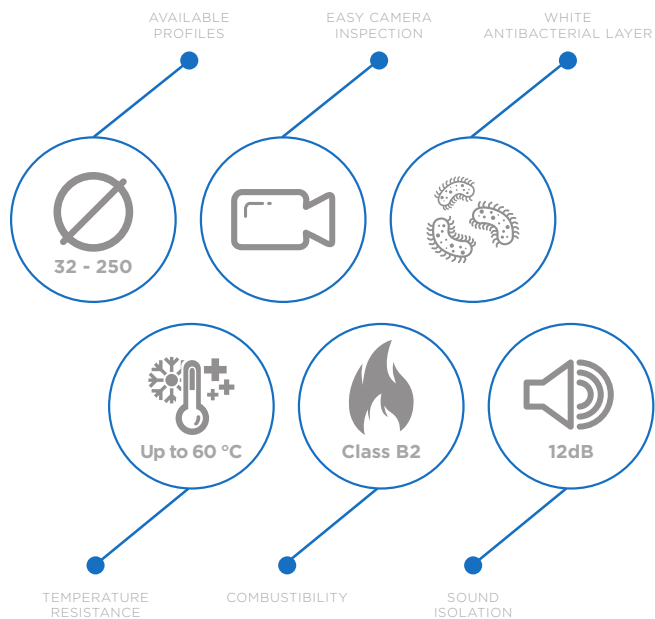

Installed with special pipe clamps (with profiled rubber ring) provides reduction in noise and acoustic vibrations up to level of 12dB(A)\*.

The latest technology of three-layer extrusion pipe and materials modified with mineral additives have raised disposal of waste water

systems within the building structure on a higher level.

\* LSC,A [dB(A)] Fraunhofer test report P-BA 213/2016e



## SPECIFICATION OF SILENT PIPES & FITTINGS

Peštan S LINE pipes are consisted of three layers, where each layer contributes to the desired characteristics of the product.

**Inner layer:** Made of polypropylene copolymer, smooth white inner surface prevents the buildup of sludge and reduces abrasion on the pipes. It allows easy inspection of the pipeline as it is white. It is resistant to high temperatures and chemicals.

**Middle layer:** Made of polypropylene copolymer and strengthened mineral filler, gives to pipes strength and flexibility.

**External layer:** Made of polypropylene copolymer, blue. Provides better impact resistance to the pipes, and greater safety when handling and installing products.

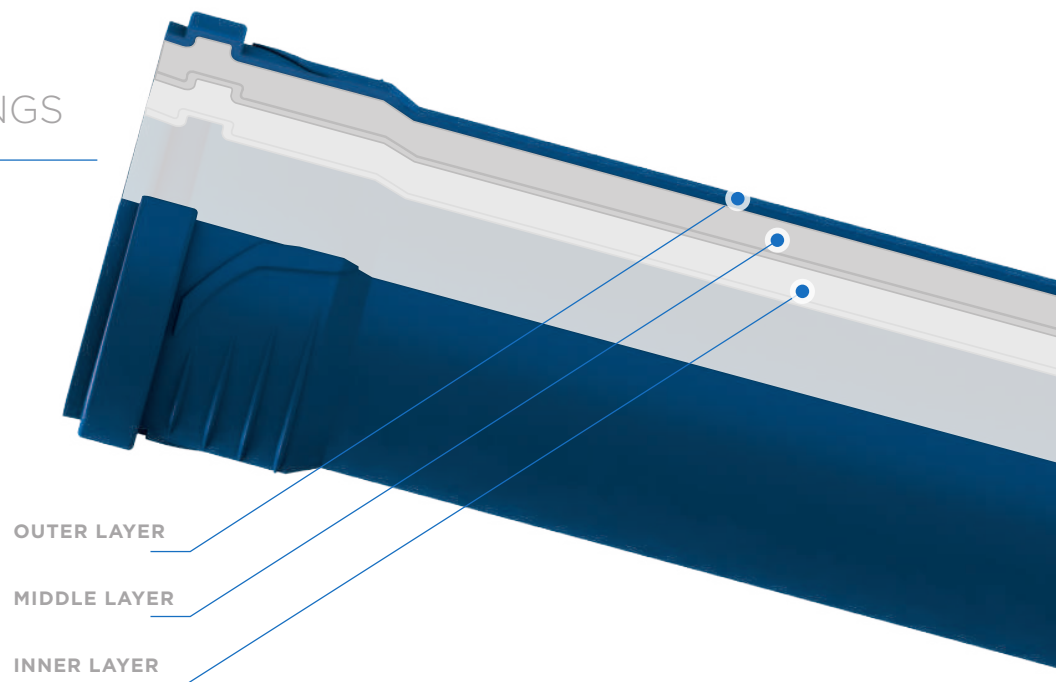

OUTER LAYER

MIDDLE LAYER

INNER LAYER

SUPPORTED STANDARDS:

EN 1451 • EN 1411 • EN 14366 • EN 681 • EN 12056

Material	PP-H (polypropylene copolymer)
Pipe structure	Three-layer composite pipe PPC-PPM-PPC
Density	pipes (Ø32-Ø160) - 1.3 g/cm <sup>3</sup> fitting - 1.4 g/cm <sup>3</sup>
Hot water resistance	short term up to 95 °C long term up to 60 °C
Linear expansion coefficient	0.05 mm/m °C
Chemical resistance	pH 2- pH 12
E - modulus	2400-3100 MPa
Joining method	Push-fit sockets with inserted rubber ring - resistant to leakage up to pressure of 0.5bar
Application category	BD (instalation in buildings and in building construction)
Fire classification	B2 - normal inflamability
Sound insulation level	12 dB(A) sound insulation Level III

## NOISE FROM WASTE WATER INSTALLATIONS

There are two types of noise in waste water installation systems:

- Airborn noise
- Structure-borne noise

### Airborn noise

Is consequence of waste water flowing within piping system. With special design of Peřtan silent pipes airborne sound is limited and kept inside pipes preventing annoying noise to leave the system.

### Structure-borne noise

Are vibrations created by flowing waste water inside pipes. From pipes it is transmitted to pipe clamps and finally to walls of the buildings creating irritating sounds. With special pipe clamps and with correct installation of the pipes this type of noise can be reduced to minimum.

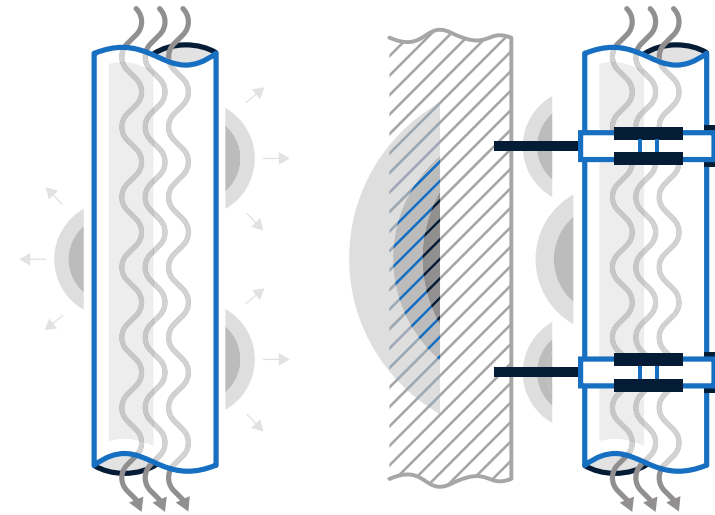

## ACOUSTIC INSULATION

According to DIN 4109 noise generated from the pipeline, built-in sound-protected areas should not exceed 35 dB (A). At the same time, the norm VDI 4100 guideline shows that the noise should not exceed 30dB (A). From the above mentioned reasons, Peštan and its S LINE system were put on testing at the renowned Institute in Stuttgart, where is obtained confirmation of our quality.

According to studies, Peštan S LINE pipes and related fittings can be classified into LEVEL III of sound insulation with results of 12dB (A)\*, obtained in the tests\*\*.

Confirmation of the effective elimination of mentioned problems is done in special acoustic laboratory for measuring noise from wastewater installation systems of Fraunhofer institute Stuttgart. The obtained value from testing of 12dB(A)\* makes Peštan S LINE system suitable for installation on places where sound insulation is taken into account (hospitals, hotels, apartment buildings, universities, libraries, dormitories etc).

\* LSC,A [dB (A)] Fraunhofer test report P-BA 213/2016e

\*\* Test was performed on bismat 1000I collars.

**Noise level of the PESTAN S LINE system in accordance with EN 14366**

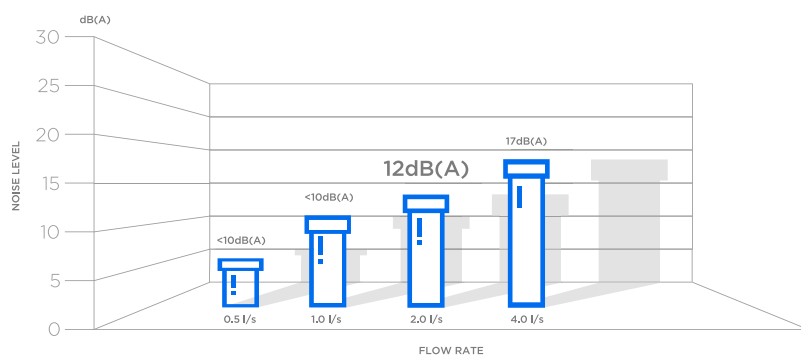

**Noise level of the PESTAN S LINE system in accordance with VDI 4100**

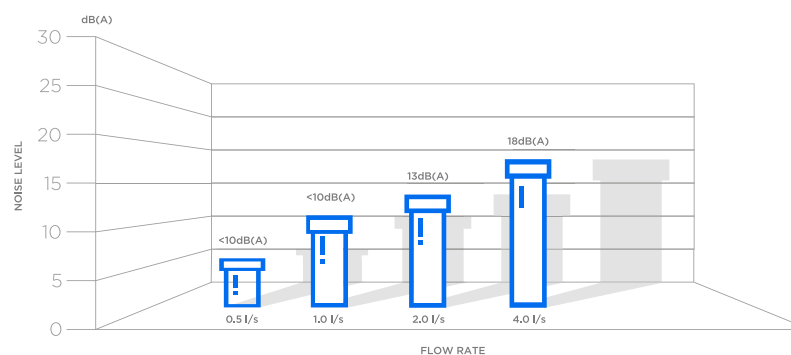

## LEVEL OF SOUND ISOLATION AND CALSSIFICATION

According to VDI 4100, there are three levels of sound insulation, depending on the purpose of the facility in which the pipes are installed:

- Level I sound insulation - requirements according to DIN 4109 corresponding to 30dB (A)
- Level II sound insulation - a higher level of sound insulation corresponds to 25dB (A)
- Level III sound insulation - the highest level of sound insulation corresponds to 20dB (A)

### VDI sound insulation clasification:

- Level I sound insulation - family houses
- Level II sound insulation - apartment buildings, residential and commercial buildings with few floors
- Level III sound insulation - hotels, hospitals, libraries, reading rooms, residential complexes...

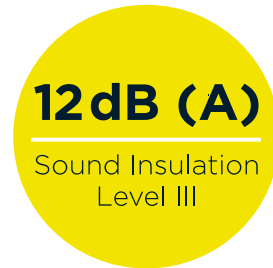

On family houses

**Sound insulation level I or on agreement**



Apartment buildings, residential and office buildings, comfort apartments

**Sound insulation level II or higher**



Hotels, hospitals, residential complexes

**Sound insulation level III enhanced agreements**

# Testing of S LINE piping system

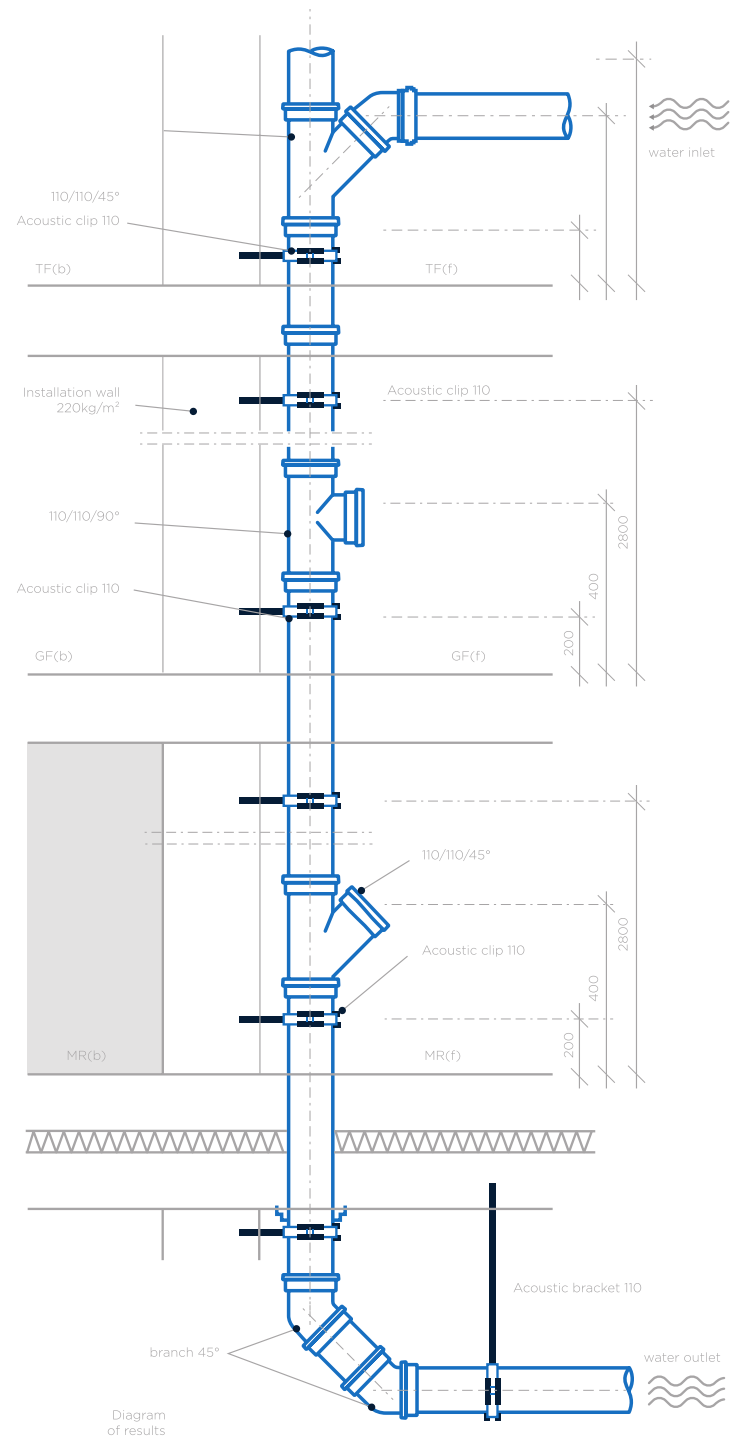
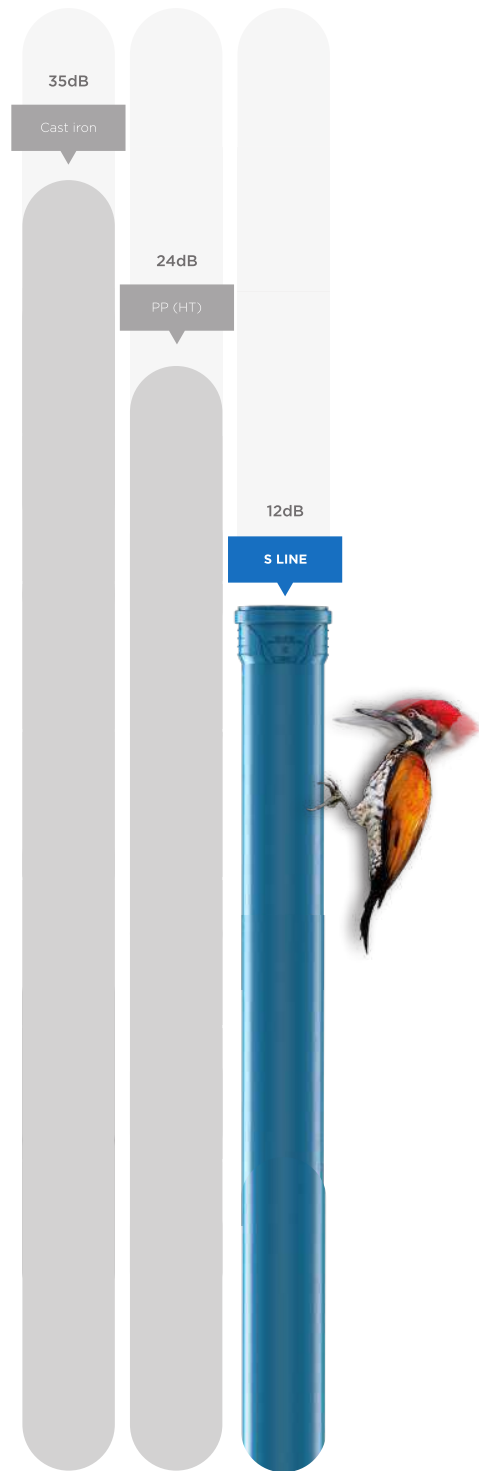

# VENTOS

## VENTILATION BRANCH

### Apliance:

- Waste water drainage in buildings
- For buildings higher then 5 floors
- Six possible ways for connections

### Tech. specification

Maximum capacity outflow 17 l/s

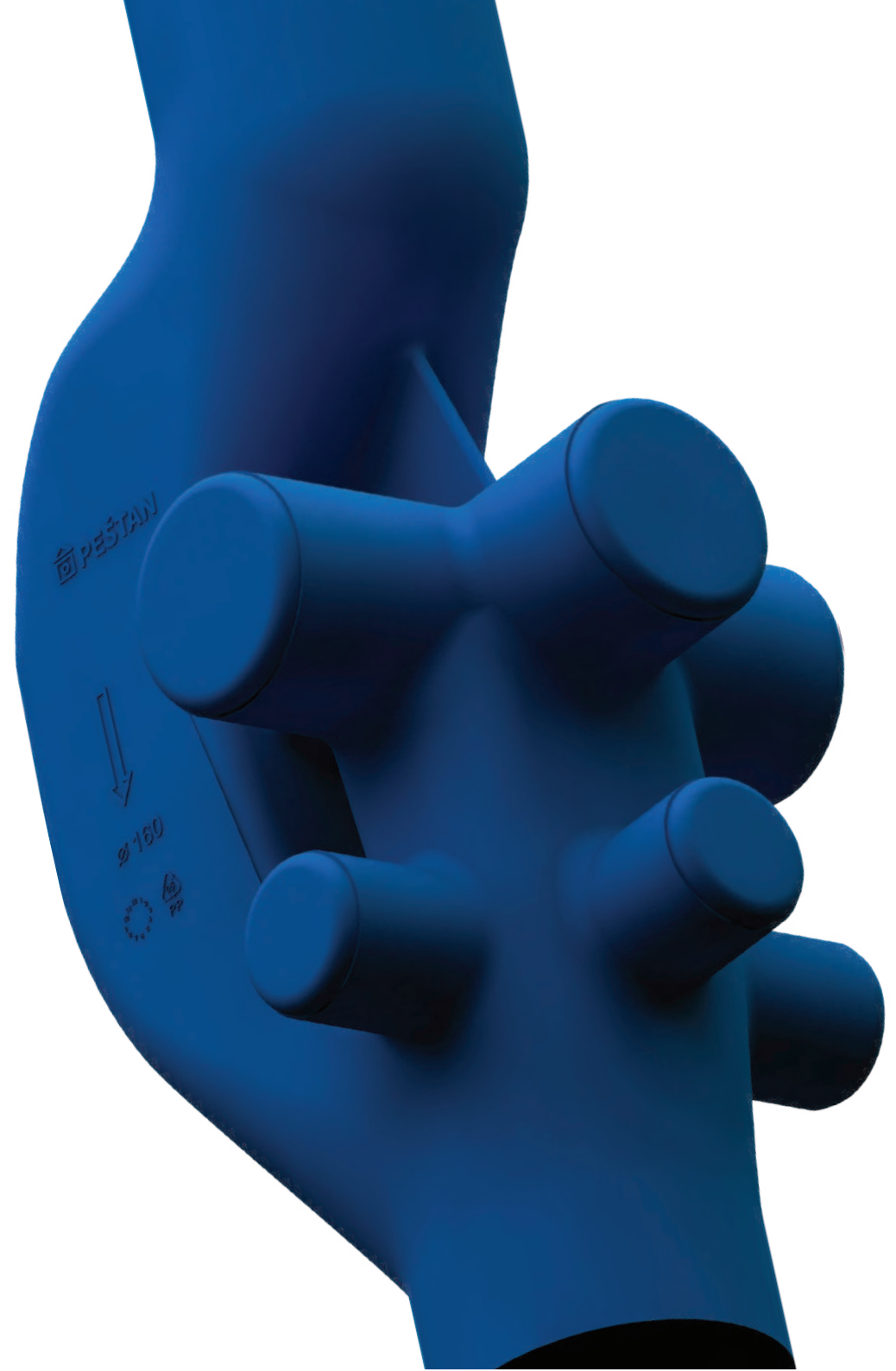



## VERTICAL CONNECTION PIECE FOR VALVES



LEFT

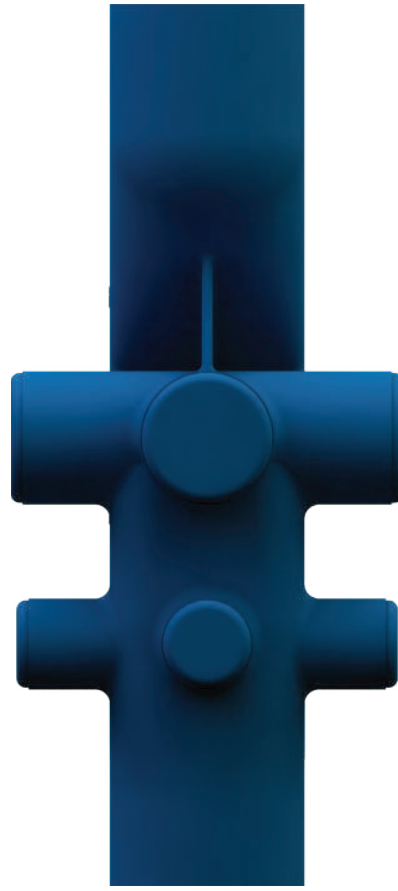

FRONT



RIGHT

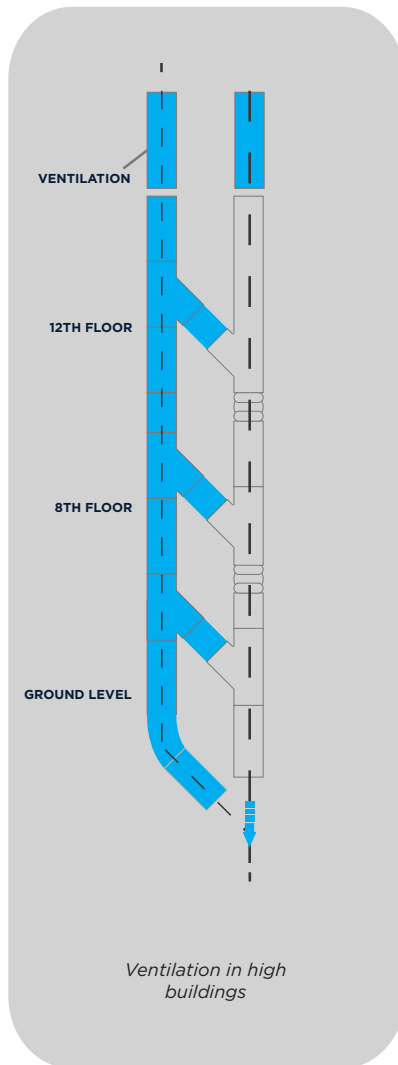

## VENTILATION BRANCH

### PARALLEL VENTILATION

During the construction of high buildings with traditional verticals the sudden change of pressure can happen in those verticals, that can lead to appearance of the subpressure that can pull the content out of the horizontal pipes attached to the vertical and that can lead to pipe cracking. Also great pressure can blow the content out of the pipes and because of those reasons during the construction the wider verticals are taken into account. Also parallel ventilation that is connected to vertical in regular spacings.

Maximum capacity for outflow is  
 DN 110 - 12 l/s  
 DN 160 - 17 l/s

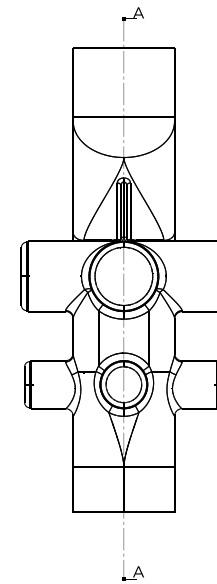

BOTTOM VIEW  
 SCALE: 1:5

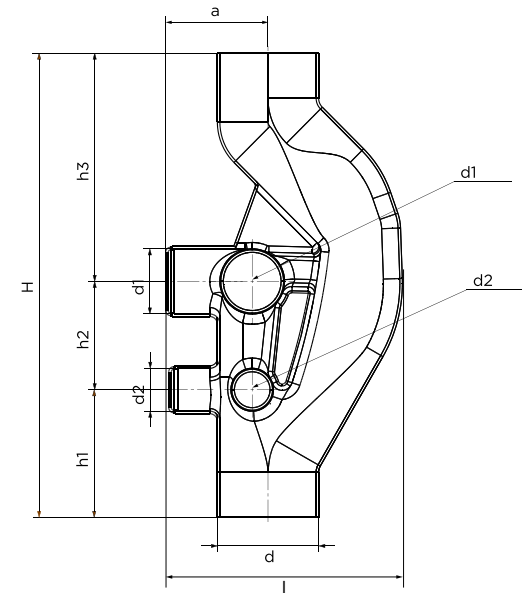

SECTION VIEW A-A  
 SCALE: 1:5

DN	d $\varnothing$	d1 $\varnothing$	d2 $\varnothing$	a	H	h1	h2	h3	l
mm	mm	mm	mm	mm	mm	mm	mm	mm	mm
110	110	110	75	135	730	245	170	315	320
160	160	110	75	147	730	359	170	200	365

### **CONNECTABLE VERTICAL PIECE - PIECE WITH GREATER CAPACITY**

#### **OPTIMIZATION OF FLOW IN HIGH BUILDINGS**

Pestan vertical piece with greater flow enables increase of the capacity on verticals up to multiple times. Also removes the necessity for creating the parallel ventilation.

### **MODERN AND ECONOMICAL SOLUTION - REPLACEMENT FOR TRADITIONAL WAY OF DRAINAGE AND VENTILATION**

Thanks to Pestan ventilation branch you can let go of traditional ways of projecting and placing of the drainage systems in buildings. Now there is economically and technically reliable solution. Besides that it provides undisturbed flow of the air between horizontal and vertical pipes Peštan ventilation branch removes any possibility of creating of air pockets in the vertical. All this enables projecting and placing of the verticals without creating parallel ventilations which decreases the costs of the constructions.

#### **COMPATIBILITY WITH PESTAN SYSTEMS**

Pestan ventilation branch is made for verticals in diameters Ø110 and Ø160 with lateral insertions 110 and 75. It is compatible with S-line, HTPP and PVC systems.

### **TRADITIONAL WAY OF CONNECTING HORIZONTAL FLOOR PIPE AND VERTICAL**

When water from vertical pipe reaches the horizontal subpressure can appear that can lead to unwanted consequences such as blow out of the pipe content.

#### **PESTAN VENTILATION BRANCH**

This hydraulically optimized piece for floor attachments enables that dimensions of verticals be smaller and it eliminates parallel vents which saves time, space and money.

- Modern technical solution
- Economical construction solution
- Increase of vertical capacity
- Compatibility with all Pestan sewage systems



## PACKING, STORAGE AND TRANSPORTATION:

---

All the fittings are packed in cardboard boxes. All pipes are packed in bundles. In order to prevent damage during transport, all Peřtan pipes and fittings must not be transported unpacked and in horizontal position. During unloading they must

be protected against damage, particularly at temperatures below freezing. Never throw, drag or bend pipes and fittings. Pipes should be stored horizontally on even surfaces up to 1.5 m high, protected against sunlight.

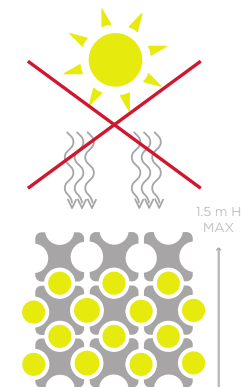
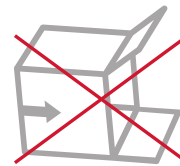
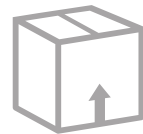

## SILENCE IS CLOSER THAN EVER

Peštan silent system provides reduction in noise and acoustic vibrations up to level of 12dB. Silence and piece in your home is closer than ever

**12dB (A)**  
Sound Insulation  
Level III





**NEW - IMPROVED** design of fitting socket



**MARKER** for determining angle of rotation of the fitting.



**REINFORCEMENT** ribs for strenghtening the fitting



Peštan logo „**THE HOUSE**” on the bottom of the fitting is used as a marker for the depth of insertion of the fitting into the socket of a pipe or other fitting.

# S LINE PIPES AND FITTINGS PRODUCT RANGE

In case of special requests, we offer possibility of building pipes above DN 160 (DN 200, DN 250, DN 315, DN 400 and DN 500).



Pipe with single socket

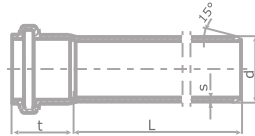

	D	L	S		D	L	S
10304500		150		10304580		150	
10304501		250		10304581		250	
10304502		500		10304582		500	
10304503		750		10304583		750	
10304504	32	1000	1.8	10304584	90	1000	2.8
10304505		1500		10304585		1500	
10304506		2000		10304586		2000	
10304507		2500		10304587		2500	
10304508		3000		10304588		3000	
10304509		4000		10304589		4000	
10304520		150		10304600		150	
10304521		250		10304601		250	
10304522		500		10304602		500	
10304523		750		10304603		750	
10304524	40	1000	1.8	10304604	110	1000	3,4+0,4
10304525		1500		10304605		1500	
10304526		2000		10304606		2000	
10304527		2500		10304607		2500	
10304528		3000		10304608		3000	
10304529		4000		10304609		4000	
10304540		150		10304620		150	
10304541		250		10304621		250	
10304542		500		10304622		500	
10304543		750		10304623		750	
10304544	50	1000	1.8	10304624	125	1000	3.9
10304545		1500		10304625		1500	
10304546		2000		10304626		2000	
10304547		2500		10304627		2500	
10304548		3000		10304628		3000	
10304549		4000		10304629		4000	
10304560		150		10304640		150	
10304561		250		10304641		250	
10304562		500		10304642		500	
10304563		750		10304643		750	
10304564	75	1000	2.3	10304644	160	1000	4.9
10304565		1500		10304645		1500	
10304566		2000		10304646		2000	
10304567		2500		10304647		2500	
10304568		3000		10304648		3000	
10304569		4000		10304649		4000	
10304700		500		10304730		500	
10304701		750		10304731		750	
10304702		100		10304732		1000	
10304703	200	1500	6.2	10304733	250	1500	7.7
10304704		2000		10304734		2000	
10304705		2500		10304735		2500	
10304706		3000		10304736		3000	
10304707		4000		10304737		4000	



Pipe with double socket

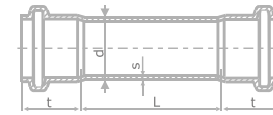



	D	L	S		D	L	S
10305000		500		10305080		500	
10305001		750		10305081		750	
10305002		1000		10305082		1000	
10305003	32	1500	1.8	10305083	90	1500	2.8
10305004		2000		10305084		2000	
10305005		2500		10305085		2500	
10305006		3000		10305086		3000	
10305007		4000		10305087		4000	
10305020		500		10305100		500	
10305021		750		10305101		750	
10305022		1000		10305102		1000	
10305023	40	1500	1.8	10305103	110	1500	3,4+0,4
10305024		2000		10305104		2000	
10305025		2500		10305105		2500	
10305026		3000		10305106		3000	
10305027		4000		10305107		4000	
10305040		500		10305120		500	
10305041		750		10305121		750	
10305042		1000		10305122		1000	
10305043	50	1500	1.8	10305123	125	1500	3.9
10305044		2000		10305124		2000	
10305045		2500		10305125		2500	
10305046		3000		10305126		3000	
10305047		4000		10305127		4000	
10305060		500		10305140		500	
10305061		750		10305141		750	
10305062		1000		10305142		1000	
10305063	75	1500	2.3	10305143	160	1500	4.9
10305064		2000		10305144		2000	
10305065		2500		10305145		2500	
10305066		3000		10305146		3000	
10305067		4000		10305147		4000	
10305160		500		10305180		500	
10305161		750		10305181		750	
10305162		100		10305182		1000	
10305163	200	1500	6.2	10305183	250	1500	7.7
10305164		2000		10305184		2000	
10305165		2500		10305185		2500	
10305166		3000		10305186		3000	
10305167		4000		10305187		4000	

CODE	DESCRIPTION	PICTURE	Z <sub>1</sub>	Z <sub>2</sub>	L <sub>1</sub> MIN	D
<b>S LINE BEND 15°</b>						
10304000	Silent bend HTB 32/15°		25	8.45	25	32
10304001	Silent bend HTB 40/15°		26.5	8.97	26.5	40
10304002	Silent bend HTB 50/15°		29.005	8.26	29.005	50
10304003	Silent bend HTB 75/15°		31.79	12.01	37.79	75
10304004	Silent bend HTB 90/15°		33.5	13.83	33.5	90
10304005	Silent bend HTB 110/15°		40.885	16.34	40.885	110
10304006	Silent bend HTB 125/15°		43.84	19.52	43.84	125
10304007	Silent bend HTB 160/15°		47.915	23.05	47.915	160
10304008	Silent bend HTB 200/15°		12.18	27.11	100	200
10304009	Silent bend HTB 250/15°		15.23	34.95	120.5	250
<b>S LINE BEND 30°</b>						
10304020	Silent bend HTB 32/30°		25	10.4	25	32
10304021	Silent bend HTB 40/30°		26.5	11.5	26.5	40
10304022	Silent bend HTB 50/30°		30.57	11.24	30.57	50
10304023	Silent bend HTB 75/30°		29.5	16.69	29.5	75
10304024	Silent bend HTB 90/30°		33.5	19.58	33.5	90
10304025	Silent bend HTB 110/30°		44.385	21.66	44.385	110
10304026	Silent bend HTB 125/30°		47.81	27.06	47.81	125
10304027	Silent bend HTB 160/30°		53.01	32.43	53.01	160
10304028	Silent bend HTB 200/30°					
10304029	Silent bend HTB 250/30°					
<b>S LINE BEND 45°</b>						
10304040	Silent bend HTB 32/45°		27.88	11.97	27.88	32
10304041	Silent bend HTB 40/45°		30.205	14.64	30.205	40
10304042	Silent bend HTB 50/45°		32.245	14.89	32.245	50
10304043	Silent bend HTB 75/45°		36.705	22.05	36.705	75
10304044	Silent bend HTB 90/45°		42.18	25.7	42.18	90
10304045	Silent bend HTB 110/45°		48.145	30.92	48.145	110
10304046	Silent bend HTB 125/45°		52.075	35.6	52.075	125
10304047	Silent bend HTB 160/45°		58.47	44.24	58.47	160
10304048	Silent bend HTB 200/45°		38.31	55.25	102	200
10304049	Silent bend HTB 250/45°		47.92	69.09	123	250
<b>S LINE BEND 67,5°</b>						
10304060	Silent bend HTB 32/67,5°		29.645	16.03	29.645	32
10304061	Silent bend HTB 40/67,5°		32.48	18.71	32.48	40
10304062	Silent bend HTB 50/67,5°		35.15	21.03	35.15	50
10304063	Silent bend HTB 75/67,5°		41.125	30.49	41.125	75
10304064	Silent bend HTB 90/67,5°		47.5	36.39	47.5	90
10304065	Silent bend HTB 110/67,5°		54.67	43.68	54.67	110
10304066	Silent bend HTB 125/67,5°		59.475	51.07	59.475	125
10304067	Silent bend HTB160/67,5°		67.955	63.7	67.955	160
10304068	Silent bend HTB 200/67,5°		61.81	80.74	104	200
10304069	Silent bend HTB 250/67,5°		77.31	101.03	125.5	250

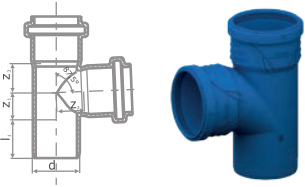

CODE	DESCRIPTION	PICTURE	Z <sub>1</sub>	Z <sub>2</sub>	L <sub>1</sub> MIN	D
<b>S LINE BEND 87,5°</b>						
10304080	Silent bend HTB 32/87,5°		31.655	20.09	31.655	32
10304081	Silent bend HTB 40/87,5°		35.07	23.77	35.07	40
10304082	Silent bend HTB 50/87,5°		38.46	27.59	38.46	50
10304083	Silent bend HTB 75/87,5°		46.155	40.69	46.155	75
10304084	Silent bend HTB 90/87,5°		54.055	48.65	54.055	90
10304085	Silent bend HTB 110/87,5°		62.1	58.545	62.1	110
10304086	Silent bend HTB 125/87,5°		67.905	68.15	67.905	125
10304087	Silent bend HTB 160/87,5°		43	84.73	43	160
10304088	Silent bend HTB 200/87,5°		88.55	109.48	107	200
10304089	Silent bend HTB 250/87,5°		110.76	137.98	128.1	250

CODE	DESCRIPTION	PICTURE	Z <sub>1</sub>	Z <sub>2</sub>	Z <sub>3</sub>	L <sub>1</sub> MIN	D
<b>S LINE BRANCH 45°</b>							
10304100	Silent branch HTEA 32/32/45°		6.78	47.68	47.6	47.22	32
10304101	Silent branch HTEA 40/32/45°		2.64	54.48	53.64	52	40
10304102	Silent branch HTEA 40/40/45°		8.28	59.24	59.41	49.72	40
10304103	Silent branch HTEA 50/32/45°		2.14	61.09	57.72	48.1	50
10304104	Silent branch HTEA 50/40/45°		3.59	64.95	64.5	55	50
10304105	Silent branch HTEA 50/50/45°		10.36	70.52	70.49	63	50
10304106	Silent branch HTEA 75/40/45°		9.22	84.015	78.12	46.5	75
10304107	Silent branch HTEA 75/50/45°		2.14	88.4	85.84	54	75
10304108	Silent branch HTEA 75/75/45°		15.53	103.97	103.79	70	75
10304109	Silent branch HTEA 90/50/45°		9.64	98.49	90.32	54	90
10304110	Silent branch HTEA 90/75/45°		8.03	113.31	110.37	72	90
10304111	Silent branch HTEA 90/90/45°		18.64	120.98	120.94	81.5	90
10304112	Silent branch HTEA 110/40/45°		26.72	107.36	96.65	42	110
10304113	Silent branch HTEA 110/50/45°		19.64	112.46	120.74	49	110
10304114	Silent branch HTEA 110/75/45°		1.97	127.72	121.75	67	110
10304115	Silent branch HTEA 110/90/45°		8.64	136.75	132.65	76	110
10304116	Silent branch HTEA 110/110/45°		22.78	146.67	145.67	92.5	110
10304117	Silent branch HTEA 125/90/45°		1.14	146.65	140.05	75	125
10304118	Silent branch HTEA 125/110/45°		15.28	159.68	156.64	89	125
10304119	Silent branch HTEA 125/125/45°		25.89	169.58	170.03	100	125
10304120	Silent branch HTEA 160/110/45°	2.22	185.82	174.3	78	160	
10304121	Silent branch HTEA 160/125/45°	8.39	193.75	188.78	89	160	
10304122	Silent branch HTEA 160/160/45°	33.14	213.57	213.49	114	160	
10304123	Silent branch HTEA 200/160/45°	13.14	221.15	215.35	99	200	
10304124	Silent branch HTEA 200/200/45°	41.42	240.35	240.35	99.58	200	
10304125	Silent branch HTEA 250/160/45°	11.86	253.15	241.53	118.86	200	
10304126	Silent branch HTEA 250/200/45°	16.42	277.35	269.53	119.58	200	
10304127	Silent branch HTEA 250/250/45°	49.84	301.53	301.53	121.16	200	

CODE	DESCRIPTION	PICTURE	Z <sub>1</sub>	Z <sub>2</sub>	Z <sub>3</sub>	L <sub>1</sub> MIN	D
<b>S LINE BRANCH 87,5°</b>							
10304130	Silent branch HTEA 32/32/87,5°		15.3	22.51	22.53	47.86	32
10304132	Silent branch HTEA 40/40/87,5°		19.08	27.3	27.62	49.92	40
10304134	Silent branch HTEA 50/40/87,5°		19.96	30.47	27.35	50.06	50
10304135	Silent branch HTEA 50/50/87,5°		23.93	31.37	31.57	52.07	50
10304136	Silent branch HTEA 75/40/87,5°		16.84	42.925	29.66	55.58	75
10304137	Silent branch HTEA 75/50/87,5°		23.39	43.57	35.96	55.47	75
10304138	Silent branch HTEA 75/75/87,5°		35.9	46.23	46.72	56.1	75
10304139	Silent branch HTEA 90/50/87,5°		23.06	51.07	68.31	64.44	90
10304140	Silent branch HTEA 90/75/87,5°		35.57	53.17	47.06	63.63	90
10304141	Silent branch HTEA 90/90/87,5°		43.08	55.3	55.41	63.42	90
10304142	Silent branch HTEA 110/40/87,5°		17.62	61.475	30.465	68.53	110
10304143	Silent branch HTEA 110/50/87,5°		22.62	62.2	35.82	69.4	110
10304144	Silent branch HTEA 110/75/87,5°		35.13	63.11	47.49	69.75	110
10304145	Silent branch HTEA 110/90/87,5°		42.6	63.32	56.25	70.75	110
10304146	Silent branch HTEA 110/110/87,5°		52.65	65.19	65.96	70.84	110
10304147	Silent branch HTEA 125/90/87,5°		42.31	72.485	70.79	73.79	125
10304148	Silent branch HTEA 125/110/87,5°		52.48	75.05	66.48	73.19	125
10304149	Silent branch HTEA 125/125/87,5°		59.83	73.99	74.55	73.17	125
10304150	Silent branch HTEA 160/110/87,5°		51.67	89.79	70.39	80.45	160
10304151	Silent branch HTEA 160/125/87,5°		59.07	93.12	77.12	80.06	160
10304152	Silent branch HTEA 160/160/87,5°		76.58	98.97	98.44	80.42	160
10304153	Silent branch HTEA 200/160/87,5°		75.71	113.15	97.35	99.29	250
10304154	Silent branch HTEA 200/200/87,5°		96.08	117.35	117.35	99.27	250
10304155	Silent branch HTEA 250/160/87,5°		74.62	138.02	103.03	119.38	250
10304156	Silent branch HTEA 250/200/87,5°		94.99	142.35	122.53	119.36	250
10304157	Silent branch HTEA 250/250/87,5°		120.26	144.53	144.53	119.34	250
<b>S LINE BEND BRANCH 87,5°</b>							
10304240	Silent bend branch HTEA 90/90/87,5°		52.13	65.85	53	63.07	90
10304241	Silent bend branch HTEA 110/90/87,5°		49.89	77.35	53.42	74.9	110
10304242	Silent bend branch HTEA 110/110/87,5°		60.53	80.51	61.35	74.54	110

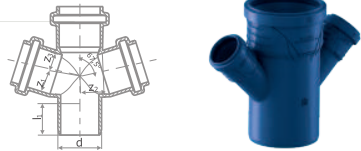
CODE	DESCRIPTION	PICTURE	Z <sub>1</sub>	Z <sub>2</sub>	Z <sub>3</sub>	L <sub>1</sub> MIN	D
<b>S LINE DOUBLE BRANCH 45°</b>							
10304190	Silent double branch HTDA 50/90/50-45°		25.25	45	25.25	54	90
10304191	Silent double branch HTDA 50/110/50-45°		25.25	55.45	25.25	49	110

<b>S LINE INSPECTION BRANCH</b>							
10304178	Silent inspection branch HTRE 50		25		31.46	51	50
10304179	Silent inspection branch HTRE 75		37.5		46.74	54.5	
10304180	Silent inspection branch HTRE 90		46.44		55.83	62.06	90
10304181	Silent inspection branch HTRE 110		55		66.15	68.5	110
10304182	Silent inspection branch HTRE 125		62.5		75.53	70.5	125
10304183	Silent inspection branch HTRE 160		80		98.78	77	160

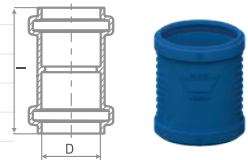
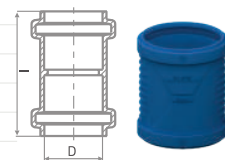
CODE	DESCRIPTION	PICTURE	L	D	DESCRIPTION	PICTURE	CODE	L	D
<b>S LINE DOUBLE SOCKET</b>					<b>S LINE SLIP COUPLER</b>				
10304200	Silent double socket HTM 32		96.9	32.7	Silent slip coupler HTU 32		10304220	96.9	32.7
10304201	Silent double socket HTM 40		104	40.7	Silent slip coupler HTU 40		10304221	104	40.7
10304202	Silent double socket HTM 50		110	50.7	Silent slip coupler HTU 50		10304222	110	50.7
10304203	Silent double socket HTM 75		119	76	Silent slip coupler HTU 75		10304223	119	76
10304204	Silent double socket HTM 90		131	90	Silent slip coupler HTU 90		10304224	131	90
10304205	Silent double socket HTM 110		147	111	Silent slip coupler HTU 110		10304225	147	111
10304206	Silent double socket HTM 125		157	126	Silent slip coupler HTU 125		10304226	157	126
10304207	Silent double socket HTM 160		176	161	Silent slip coupler HTU 160		10304227	176	161
10304208	Silent double socket HTM 200		212	201	Silent slip coupler HTU 200		10304228	212	201
10304209	Silent double socket HTM 250		251	251.5	Silent slip coupler HTU 250		10304229	251	251.5

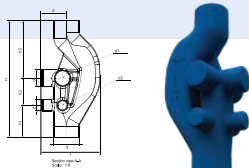
CODE	DESCRIPTION	PICTURE	DN	d, ø	d1 ø	d2 ø	a	b	h	h1	h2	l	l1	l2
<b>VENTOS VENTILATION BRANCH</b>														
40006502	VENTOS VENTILATION BRANCH ø160/ø110/ø75		160	160	110	75	13.39	9.5	19	17	35	13	8	11
40006918	VENTOS VENTILATION BRANCH ø110/ø110/ø75		110	110	110	75	13	8	21.5	17	35.5	10.5	5.5	9.5

CODE	DESCRIPTION	PICTURE	Z1	L1MIN	D	D1
<b>S LINE EXCENTRIC REDUCER</b>						
10304160	Silent reducer HTR 40/32		15.19	54.88	40	32.7
10304161	Silent reducer HTR 32/40		10.435	54.88	40	36.9
10304163	Silent reducer HTR 40/50		17.32	57.88	50	40.7
10304164	Silent reducer HTR 50/40		17.32	57.88	50	40.7
10304165	Silent reducer HTR 75/50		20.94	62.26	75	50.7
10304177	Silent reducer HTR 90/40		19.17	71.16	90	44.9
10304166	Silent reducer HTR 90/50		16.34	70.36	90	54.9
10304167	Silent reducer HTR 90/75		19.1	71.54	90	81
10304168	Silent reducer HTR 90/110		13.025	77.48	110	96.8
10304169	Silent reducer HTR 90/125		13.365	81.51	125	96.8
10304170	Silent reducer HTR 110/40		9.95	77.63	110	44.9
10304171	Silent reducer HTR 110/50		16.89	76.81	110	50.7
10304172	Silent reducer HTR 110/75		19.79	77.54	110	76
10304173	Silent reducer HTR 125/110		19.03	82.63	125	111
10304175	Silent reducer HTR 160/125		22.94	92.09	160	126
10304184	Silent reducer HTR 200/160		27.15	99	200	172
10304185	Silent reducer HTR 250/200	34.47	120	250	214.6	

CODE	DESCRIPTION	PICTURE	Z1	L1MIN	D	D1
<b>S LINE CAP FOR SOCKET</b>						
10304260	Silne pp Cap for socket ø32 (box)		15.19	54.88	40	32.7
10304261	Silne pp Cap for socket ø40 (box)		10.435	54.88	40	36.9
10304262	Silne pp Cap for socket ø50 (box)		17.32	57.88	50	40.7
10304263	Silne pp Cap for socket ø75 (box)		17.32	57.88	50	40.7
10304264	Silne pp Cap for socket ø90 (box)		20.94	62.26	75	50.7
10304265	Silne pp Cap for socket ø110 (box)		19.17	71.16	90	44.9
10304266	Silne pp Cap for socket ø125 (box)		16.34	70.36	90	54.9
10304267	Silne pp Cap for socket ø160 (box)		19.1	71.54	90	81

CODE	DESCRIPTION	PICTURE	SIZE D (MM)	L (MM)	L1 (MM)	W (MM)	STD PCK
------	-------------	---------	-------------	--------	---------	--------	---------

40006639

S LINE P TRAP,BLUE DN 110 MM

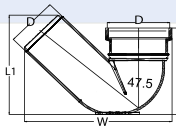

110

167

269

176

10

CODE	DESCRIPTION	PICTURE	SIZE D (MM)	D (MM)	D1 (MM)	H (MM)	H1 (MM)	W	STD PCK
------	-------------	---------	-------------	--------	---------	--------	---------	---	---------

40006640

S LINE FLOOR TRAP,BLUE DN 110/DN75/  
DN50 MM

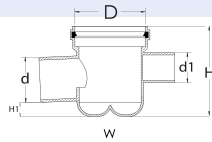

110

75

50

141

50

213

10

CODE	DESCRIPTION	PICTURE	SIZE D (MM)	D (MM)	D1 (MM)	H (MM)	H1 (MM)	W	STD PCK
------	-------------	---------	-------------	--------	---------	--------	---------	---	---------

40006641

S LINE DEEP FLOOR DN110/75/50 MM

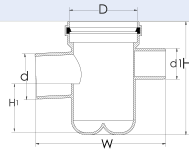

110

75

50

175

72

213

10



# PVC (KG) PIPES

---

BELOW GROUND

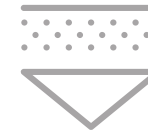

For domestic & street sewage systems

**The pipes for domestic and street sewerage systems together with the appropriate coupling sleeves are intended to be used for the removal of all kinds of waste water.**

Assembly of the pipeline is extremely easy , pipes are connected to one another with fittings while complete seal is achieved with use of rubber bands. Maximum temperature of application is +600 °C. Pipes are resistant to salt water, alcohol, acids, alkalis, sulphates, aggressive gas and all kinds of detergents. On the other hand, they cannot be used for the transport of water which contains high percentage of benzene, benzine (petrol) or acetone.

## Technical data & characteristics

- Very light material
- Simple and easy way of both transport and manipulation
- Fast and cheap assembling
- Pipe connections are resistant to water and other type of fluids
- They are resistant to corrosion in alkaline, acid or aggressive environment



- They are fine electrical insulator, and also resistant to mechanical impact
- Guaranteed life time of more than 50 years
- Practically no costs of pipeline maintenance
- Connection with muffs and gaskets made of EPDM or rubber (EN 681)
- SRPS EN 1401/SRPS EN 13476\*

\*SRPS EN 1401 - European norm for production of full wall compact PVC pipes. SRPS EN 13476 - European norm for production of three layer PVC pipes.

## Material characteristics:

- Specific mass  $1,38 \div 1,45 \text{ gr/cm}^3$
- Tensile strenght 50-60 MPa
- Thermal stability: according to Vicat min  $79 \text{ }^\circ\text{C}$
- Thermal conductivity  $0,54 \text{ KJ/mh/}^\circ\text{C}$
- Linear ratio of thermal extension  $0,08 \text{ mm/m/}^\circ\text{C}$
- Water absorption  $4 \text{ mg/cm}^2$



## APPLICATION AND STATIC RECOMENDATION

---

**What pipe series should be used depends on location, ground quality and type of foundation, other various conditions, etc.**

**Pipe series S-20 and S-16 are used in normal conditions, i.e. for normal type of ground, trenches, burial methods and ground compression.**

**Pipe series S-25 are laid in terrains with extremely incoherent material. Deformation of the cross section is checked after one to three months from laying of pipeline.**

With pipe series S-20 and S-16 deformation cannot be higher than 5% of outer pipe diameter, while the maximum deformation after two years cannot be higher than 10% of diameter.

With pipe series S-25, after one to three months from laying of pipeline, maximum deformation will not be higher than 5%, while deformation after 2 years is allowed to be up to 8%.

Laying of sewerage pipes and fittings is allowed without any specific static evidence, and in accordance with the following conditions:

- Bellow traffic surfaces with traffic loading up to 30 tons, minimum covering layer should be 1,5 m.
- Bellow non-traffic surfaces or surfaces which are temporarily exposed to light vehicle traffic, minimum covering layer should be 0,8 m.
- While laying the pipeline bellow the buildings, covering layer above the pipe socket must be at least 150 mm.
- Protection pipes should be used if the loading from the mounted construction parts cannot be avoided.
- While laying the pipeline in the trenches with minimum width, covering layer must not be higher than 6 m; on the other hand, while laying the pipeline below the protective dam and in wide trenches, covering layer should not be higher than 4 m.
- Filling soil should have the following approximate characteristics:  $8 \leq 20,5 \text{ KN/m}^2$
- $8 \leq 22,50$  (angle  $\phi$ )
- Laying the pipeline in the area with ground water is allowed only if the removal of the filling material is prevented. Removal is prevented by laying the pipeline in the filter layer made of gravel or concrete.
- If not acting completely in accordance with these norms it is necessary to calculate the pipe carrying ability, while standard conditions of filling and ground compression should be provided (DIN 4033, EN); this means that in the pipeline zone, from the bottom of the trench up to at least 30 cm above the vertex of the pipe the following ground compression values should be achieved:
  - 97% density of un shoveled soil for binding ground.
  - 95% density of unshoveled soil for binding ground.
  - All values of ground compression should be proven during handling.
  - Pipeline zone (from the bottom of the trench up to at least 30 cm above the vertex of the pipe) is filled with material which does not contain stones and at the same time can be compressed. Filling material, which will be in direct contact with the pipe, can be taken from the ground pile came from shoveled trench, which should be previously cleared from large pieces. Ground compression around the pipe can be done manually or by using hydraulic tools. Each time material is filled only up to vertex of the pipe while the ground compression is being done sidewise, never in the zone occupied by the pipe. Filling material is being compressed until well sidewise support of the sewerage trench is provided. Material is being filled above the vertex of the pipe in layers, in a way that the higher layers are compressing the lower ones.

## PIPE SERIES SPECIFICATION

---

### Pipe series S-25 (SDR 51) SN 2 KN/m

- Depth of pipe trench min 1,2 ÷ 4 m max
- Maximum loading max 12t/axel
- Ring stiffness SN 2 KN/m<sup>2</sup>
- Connection with EPDM or rubber (EN 681) seal in socket
- Length 1 ÷ 6 m

### Pipe series S-20 (SDR 41) SN 4 KN/m<sup>2</sup>

- Depth of pipe trench min 1,2 ÷ 6 m max
- Maximum loading max 18t/axel
- Ring stiffness SN 4 KN/m<sup>2</sup>
- Connection with EPDM or rubber (EN 681) seal in socket
- Length 1 ÷ 6 m

### Pipe series S-16 (SDR 34) SN 8 KN/m<sup>2</sup>

- Depth of pipe trench min 1,2 ÷ 6 m max
- Maximum loading max 18t/axel
- Ring stiffness SN 8 KN/m<sup>2</sup>
- Connection with EPDM or rubber (EN 681) seal in socket
- Length 1 ÷ 6 m

FITTING OF SN4 CLASS CAN BE USED WITH PIPES SN8,  
BECAUSE OF THEIR GEOMETRY THEY HAVE STRENGTH OF SN8.

## SADDLE AFTER GRIP (SAG)

**Saddle after grip is new, modern product, with great performance.**

It is intended for subsequent connection to an existing pipeline for smooth as well as corrugated pipes. Using this system, combined with a great range of Peštan fittings, production of new lines of home, street and drain sewer, as well as connecting to existing lines becomes satisfaction.





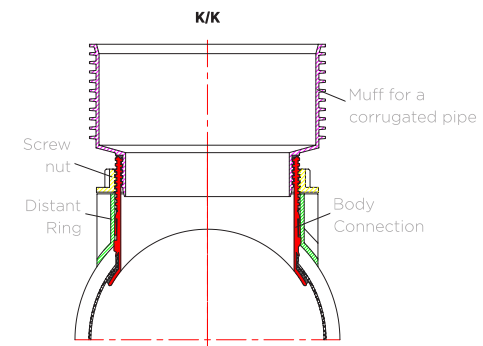
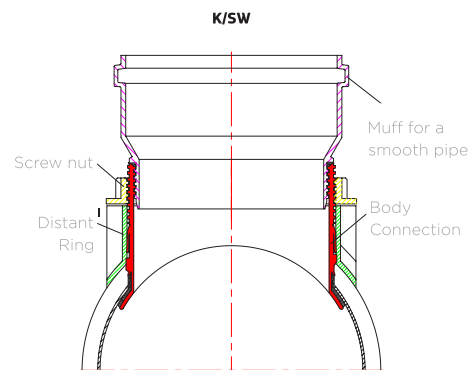

Peštan latest product main purpose is to be subsequently attached to an existing pipeline with a connection to smooth and corrugated pipes. The connection is safe and waterproof. It is made of ABS by injection molding technology.

## SIZES

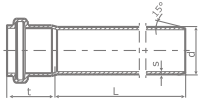

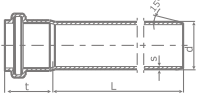
Sizes are given in the following table:

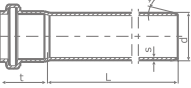

K/K CODE	K/SW CODE	
10799210	10799110	250/160
10799211	10799111	300/160
10799212	10799112	400/160
10799213	10799113	500/160
10799214	10799114	600/160
K/K CODE	K/SW CODE	
10799200	10799100	250/200
10799201	10799101	300/200
10799202	10799102	400/200
10799203	10799103	500/200
10799204	10799104	600/200

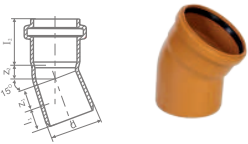
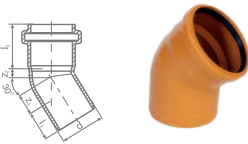
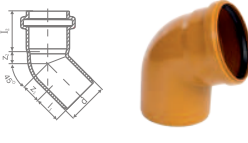
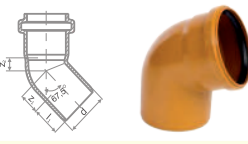
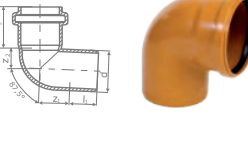

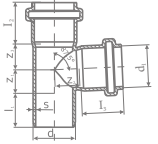
DESCRIPTION	PICTURE	CODE	D	S	T
<b>KG PIPE SDR51 SN2</b>					
		10400044	160	3,2	86
		10400054	200	3,9	106
		10400074	250	4,9	128
		10400104	315	6,2	155
		10400144	400	7,9	183
		10400184	500	9,8	210
10410560	630	12,3	188		
<b>KG PIPE SDR41 SN4</b>					
		10400304	110	3,2	61
		10400324	125	3,2	72
		10400344	160	4,0	86
		10400364	200	4,9	106
		10400384	250	6,2	128
		10400404	315	7,7	155
		10400444	400	9,8	183
		10400484	500	12,3	210
10410360	630	15,4	188		
<b>KG PIPE SDR34 SN8</b>					
		10400604	110	3,2	61
		10400624	125	3,7	72
		10400644	160	4,7	86
		10400664	200	5,9	106
		10400684	250	7,3	128
		10400704	315	9,2	155
		10400744	400	11,7	183
		10400784	500	14,6	210
10410160	630	18,4	188		

DESCRIPTION	PICTURE	CODE	D	S	Z1	Z2	L1MIN	L2
<b>KGB BEND 15°</b>								
	10401362	110	3,2	6,1	20	61	49,1	
	10401363	125	3,2	7,9	21	68	54,6	
	10401360	160	4	10,1	26,2	81	86	
	10401361	200	4,9	26	30	99	106	
	*11500002	250	6,2	18	30	125	128	
	*11500003	315						
	*11500005	400						
	*11500007	500						
<b>KGB BEND 30°</b>								
	10401020	110	3,2	14,7	27,1	61	49,6	
	10401021	125	3,2	16,7	29,1	68	54,6	
	10401022	160	4	24	30	81	86	
	10401023	200	4,9	30	39	99	106	
	*11500102	250	6,2	37	49	125	128	
	*11500103	315						
	*11500105	400						
	*11500107	500						
<b>KGB BEND 45°</b>								
	10401120	110	3,3	22,9	34,7	61	49,1	
	10401121	125	3,3	26	37,8	68	54,6	
	10401102	160	4	36	44	81	86	
	10401103	200	4,9	46	55	99	106	
	10401104	250	6,2	57	69	125	128	
	10401105	315	7,7	72	86	132	155	
	10401106	400	9,8	83,3	117,9	150	119	
	*11500205	500						
<b>KGB BEND 67.5°</b>								
	10401320	110	3,3	54,67	43,68	61	49,1	
	10401321	125	3,3	59,475	51,07	68	54,6	
	10401302	160	4	67,955	63,7	81	86	
	10401303	200	4,9	61,81	80,74	99	106	
	10401304	250	6,2	77,31	101,03	125	128	
<b>KGB BEND 87.5°</b>								
	10401320	110	3,3	53,2	62,8	61	49,1	
	10401321	125	3,3	60,4	70	68	54,6	
	10401302	160	4	83	89	81	86	
	10401303	200	4,9	105	114	99	106	
	10401304	250	6,2	131	143	125	128	
	10401305	315	7,7	165	180	132	155	
	10401326	400	9,8	193,3	121,2	150	119	
	*11500405	500						

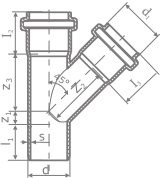
DESCRIPTION	PICTURE	CODE	D/D1	S	Z1	Z2	Z3	L1MIN	L2	L3
KGEA BRANCH 87,5°										
										
										
		10401630	110/110	3,3	52,7	67,3	67,3	61	49,1	49,1
		10401631	125/110	3,3	52,4	67,6	67,6	68	54,6	49,1
		10401632	125/125	3,3	59,9	75,1	75,1	68	54,6	54,6
		10401603	160/110	4	58	86	64	81	86	61
		10401604	160/125	4	66	87	71	81	86	72
		10401605	160/160	4	83	89	89	81	86	86
		10401606	200/110	4,9	62	105	64	99	106	61
		10401607	200/125	4,9	69	75	101	75	106	72
		10401608	200/160	4,9	86	108	90	99	106	86
		10401609	200/200	4,9	106	111	111	99	106	106
		10401619	250/110	6,2	90	132	100	120	128	61
		10401620	250/125	6,2	90	132	100	120	128	72
		10401610	250/160	6,2	89	132	91	125	128	86
		10401611	250/200	6,2	108	134	111	125	128	106
		10401612	250/250	6,2	131	138	138	125	128	128
		10401618	315/110	7,7	93	162	104	134	155	61
		10401617	315/125	7,7	93	162	104	134	155	72
		10401613	315/160	7,7	93	164	104	134	155	86
		10401614	315/200	7,7	111	165	113	132	155	106
		10401615	315/250	7,7	134	169	139	132	155	128
		10401616	315/315	7,7	165	173	173	132	155	155
		10401621	400/110	9,8	106	206,5	131,8	150	124,2	51,3
		10401622	400/160	9,8	106	209,7	131,8	150	124,2	65
		10401623	400/200	9,8	106	214,5	131,8	150	124,2	77,5
		*11501232	400/110							
		*11501233	400/125							
		*11501234	400/160							
		*11501235	400/200							
		*11501236	400/250							
		*11501237	400/315							
		*11501239	400/400							
		*11501249	500/110							
		*11501250	500/125							
		*11501251	500/160							
		*11501252	500/200							
		*11501253	500/250							
		*11501254	500/315							
		*11501256	500/400							
		*11501258	500/500							
		*11501056	500/400							
		*11501058	500/500							

DESCRIPTION	PICTURE	CODE	D/D1	S	Z1	Z2	Z3	L1 <sub>MIN</sub>	L2	L3
<b>KGEA BRANCH 45°</b>										
 	10401430	110/110	3,3	22,8	138,2	138,2	61	49,1	49,1	
	10401431	125/110	3,3	15,3	148,8	145,7	68	54,6	49,1	
	10401432	125/125	3,3	25,9	156,3	156,3	68	54,6	54,6	
	10401403	160/110	4	1	168	159	81	86	61	
	10401404	160/125	4	12	176	169	81	86	72	
	10401405	160/160	4	36	194	194	81	86	86	
	10401406	200/110	4,9	-16	195	177	99	106	61	
	10401407	200/125	4,9	7	212	201	81	106	72	
	10401408	200/160	4,9	19	220	213	99	106	86	
	10401409	200/200	4,9	46	241	241	99	106	106	
	10401419	250/110	6,2	32	228	209	165	128	61	
	10401420	250/125	6,2	21	236	220	154	128	72	
	10401410	250/160	6,2	-4	253	236	125	128	86	
	10401411	250/200	6,2	23	274	264	125	128	106	
	10401412	250/250	6,2	57	300	300	125	128	128	
	10401418	315/110	7,7	2	272	244	160	155	61	
	10401417	315/125	7,7	-8	279	254	154	155	72	
	10401413	315/160	7,7	-32	297	278	126	155	86	
	10401414	315/200	7,7	-6	318	295	132	155	106	
	10401415	315/250	7,7	28	344	331	132	155	128	
	10401416	315/315	7,7	72	378	378	132	155	155	
	10203703	400/160	15,3	22	370	255	178	155	75	
	10203703	400/200	15,3	62	390	215	178	155	90	
	*11501032	400/110								
	*11501033	400/125								
	*11501034	400/160								
	*11501035	400/200								
	*11501036	400/250								
	*11501037	400/315								
	*11501039	400/400								
*11501049	500/110									
*11501050	500/125									
*11501051	500/160									
*11501052	500/200									
*11501053	500/250									
*11501054	500/315									
*11501056	500/400									
*11501058	500/500									
*11501258	500/500									
*11501056	500/400									
*11501058	500/500									

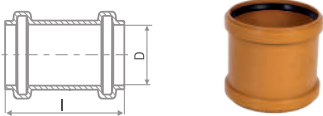
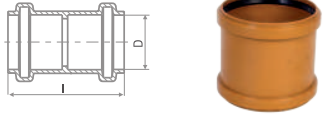
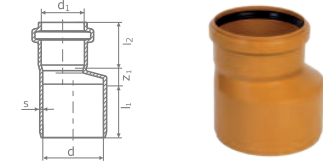
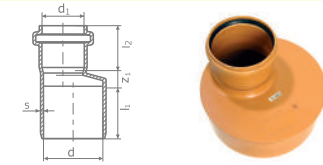
DESCRIPTION	PICTURE	CODE	D (D/D1)	L1 <sub>MIN</sub>		
<b>KGU SLEEVE SOCKET</b>						
	10402720	110	122,2			
	10402721	125	131,2			
	10402702	160	158			
	10402703	200	158			
	10402704	250	250			
	10402705	315	293			
	10402706	400	244			
*11502310	500					
<b>KGU DOUBLE SOCKET</b>						
	10402620	110	122,2			
	10402621	125	131,2			
	10402602	160	158			
	10402604	250	250			
	10402605	315	293			
	10402626	400	244			
	*11502410	500				
<b>KGR EXCENTRIC REDUCER</b>						
	10401730	125/110	3,3	23,3	67	49,1
	10401701	160/110	4	34	81	61
	10401702	160/125	4	27	81	72
	10401703	200/110	4,9	26	125	61
	10401705	200/160	4,9	32	99	86
	10401709	250/200	6,2	38	125	106
	10401714	315/250	7,7	46	132	128
	10401734	200/125	4,9	25	99,8	52
	10401737	250/160	6,2	28	126	63
	10401738	250/110	6,2	26	124	48
	10401743	315/160	7,7	30	132	65
	<b>KGR REDUCER</b>					
		*10401750	110/200	4,9	5	61
*10401800		110/250	6,1	7	61	90
*10401810		110/315	7,7	40	61	93
*10401820		110/400	6	40	61	95
*10401751		125/200	4,9	5	72	59
*10401801		125/250	6,1	7	72	90
*10401811		125/315	7,7	40	72	93
*10401821		125/400	9,8	40	72	95
*10401802		160/250	6,1	8	86	90
*10401812		160/315	7,7	7	86	93
*10401822		160/400	9,8	50	86	95
*10401813		200/315	7,7	7	106	93
*10401823		200/400	9,8	50	106	95
*10401824		250/400	9,8	50	128	95
*11503027		315/400				
*11503044	400/500					

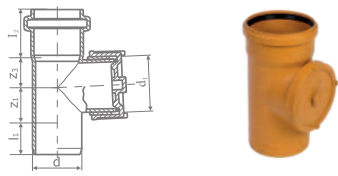

DESCRIPTION	PICTURE	CODE	(D/D1)	S	Z1	Z2	L1MIN	L2
<b>INSPECTION PIPE</b>								
	10401920	110/110	3,3	51,7	52,68	67	49,1	
	10401921	125/110	3,3	51,7	51	72	54,6	
	10401902	160/160	4	83	89	81	86	
	10401903	200/160	4,9	86	111	99	106	
	10401904	250/160	6,2	89	91	125	128	
	10401905	315/160	7,7	93	104	134	155	
	*11502603	400/160						

DESCRIPTION	PICTURE	CODE	D	S	L
<b>KG END CAP</b>					
	10402904	200	4,9	51,5	
	10402900	250	6,2	90	
	10402901	315	7,7	92,5	
	10402902	400	9,8	95	
	*11502504	500	12,3	120	

DESCRIPTION	PICTURE	CODE	D	S	L
<b>KGK END CAP</b>					
	10402030	110	3,4	45	
	10402031	125	3,4	45	
	10402032	160	4,2	53	
	10402033	200	5,2	64	

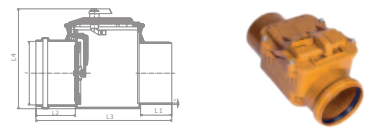
DESCRIPTION	PICTURE	CODE	D	S	L1	L2	L3	L4
<b>NON-RETURN VALVE</b>								
	10202502	110	4,0	64	64	320	189	
	10202503	125	4,0	68	65	318	226	
	10202504	160	4,0	68	103	350	248	
	10402000	200	4,5	100	86	455	300	
	10402001	250	6,2	144	104	566	365	
	10402002	315	7,7	160	116	728	454	

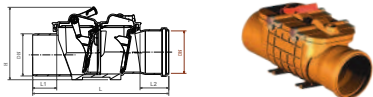
<b>NON-RETURN VALVE WITH TWO CLAPS</b>								
	10202505	110	4,0	62	62	355	190	
		160						
		200						

DESCRIPTION	PICTURE	CODE	D	S	Z1	L2
<b>CLAP VALVE</b>						
	10402041	125	3,3	20	52	
	10402042	160	4	25	62	

DESCRIPTION	PICTURE	CODE	(D/D1)
SAG K/K		10799210	250/160
		10799211	300/160
		10799212	400/160
		10799213	500/160
		10799214	600/160
		10799200	250/200
		10799201	300/200
		10799202	400/200
		10799203	500/200
		10799204	600/200

SAG K/SW		10799110	250/160
		10799111	300/160
		10799112	400/160
		10799113	500/160
		10799114	600/160
		10799100	250/200
		10799101	300/200
		10799102	400/200
		10799103	500/200
		10799104	600/200

DESCRIPTION	PICTURE	CODE	(D/D1)	H	H1	H2	L
DRAIN MANHOLES		10799224	315/160	384	281	190	479
		10799220	400/160	420	315	207	554
		10799221	400/200	470	340	207	586

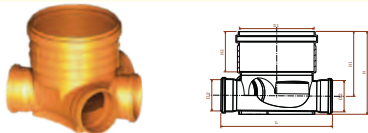
DRAIN MANHOLES		10799225	315/160	395	309	185	490
		10799222	400/160	420	319	207	559
		10799223	400/200	470	344	207	584

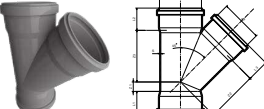
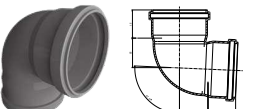
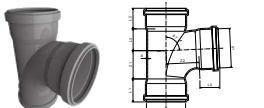
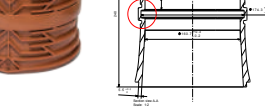
DESCRIPTION	PICTURE	D	D1	S	Z1	Z2	L1MIN	L2	L3
KGB BEND 110/45°		110		3.1	33.02	33.02	58.53	58.53	
KGB BEND 125/45°		125		3.6	36.92	36.92	64.46	64.46	
KGB BEND 160/45°		160		4.5	45.46	45.46	79.42	79.42	
KGB BEND 110/87.5°		110		3.1	61.15	61.15	58.53	58.53	
KGB BEND 125/87.5°		125		3.6	68.85	68.85	64.46	64.46	
KGB BEND 160/87.5°		160		4.5	86.35	86.35	79.42	79.42	
KGEA BRANCH 110/110-45°		110	110	3.1	24.94	133.47	58.53	58.53	58.53
KGEA BRANCH 125/110-45°		125	110	3.7	16.07	146.47	64.46	64.46	58.53
KGEA BRANCH 125/125-45°		125	125	3.7	26.07	152.53	64.46	64.46	64.46
KGEA BRANCH 160/110-45°		160	110	4.7	1.15	173.97	90	79.42	58.53
KGEA BRANCH 160/125-45°		160	125	4.7	11.15	178.53	88.85	79.42	64.46
KGEA BRANCH 160/160-45°		160	160	4.7	36.15	195.57	88.85	79.42	79.42
KGEA BRANCH 110/110-87.5°		110	110	3.2	79.94	91.47	65.06	58.53	58.53
KGEA BRANCH 125/110-87.5°		125	110	3.7	68.07	93.65	140	64.46	58.53
KGEA BRANCH 125/125-87.5°		125	125	3.7	83.07	95.61	71.93	64.46	64.45
KGEA BRANCH 160/110-87.5°		160	110	4.7	66.15	123.62	88.85	79.42	58.53
KGEA BRANCH 160/125-87.5°		160	125	4.7	69.15	111.65	88.85	79.42	64.45
KGEA BRANCH 160/160-87.5°		160	160	4.7	101.15	120.57	88.85	79.42	79.42

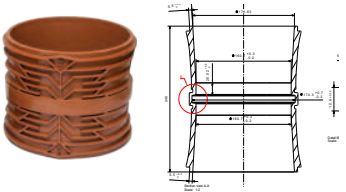
DESCRIPTION	PICTURE	CODE
KGF FLOOD GATE Ø110		10203680
KGF FLOOD GATE Ø125		10203681
KGF FLOOD GATE Ø160		10203682
KGF FLOOD GATE Ø200		10203683
KGF FLOOD GATE Ø250		10203684
KGF FLOOD GATE Ø315		10203685
KGF FLOOD GATE Ø400 WELDED		11502908
KGF FLOOD GATE Ø500 WELDED		11502909

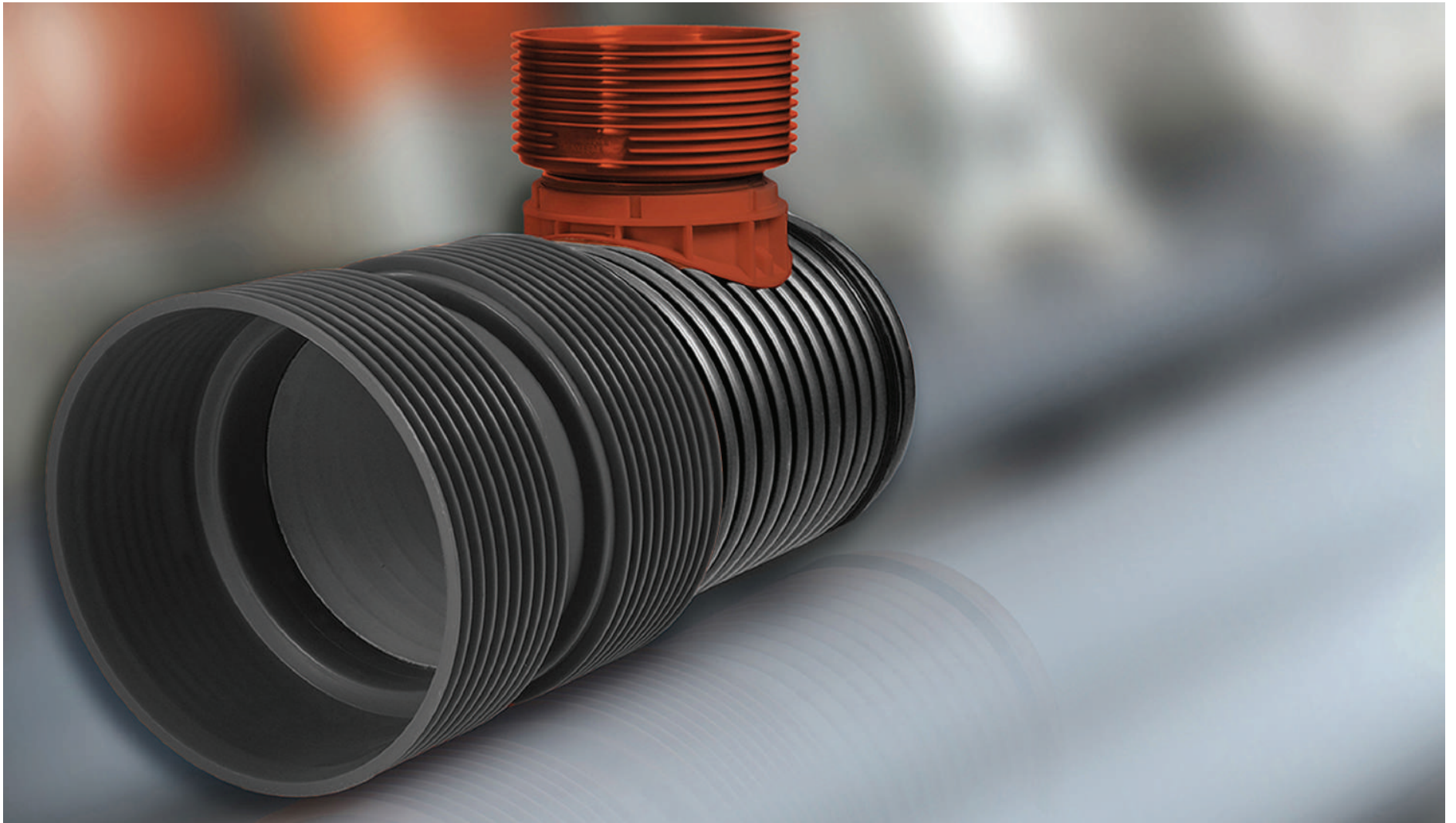

# PP CORRUGATED ID PIPES

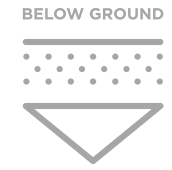

Double layered corrugated PP ID pipes and fittings

## PRODUCTION AND PURPOSES

**Peštan Company supplies for its corrugated pipes only certified materials from top manufacturers.**

These raw materials are satisfying properties of high impact resistance that have polypropylene copolymer PP-B. It is very important to make the correct choice of pipe by the type of fluid and by conditions of exploitation, in accordance with the characteristics of the material from which they are made of.

CHARACTERISTICS	VALUE	EN
Density	900 kg/m <sup>3</sup>	EN 1183
MFR	0,3 gr/10 min (230/2,16)	EN1133
Modulus of elasticity	1500/2000MPa	EN527
Tensile strength at yield point	32 MPa	EN527
Impact toughness by Sharp with a comma	+23 °C 70kJ/m <sup>2</sup>	EN179/1eA
	-23 °C 7 kJ/m <sup>2</sup>	EN179/1eA



## MATERIAL

**Material properties and temperature application are given in the following table:**

MATERIAL	MIN.	MAX.	SHORT-TERM
PP	-20 °C	60 °C	95 °C
PE-HD	-40 °C	40 °C	70 °C
PVC-U	0 °C	40 °C	60 °C

## PRODUCTION

### Pipes are manufactured in accordance with SRPS-EN13476 and EN1440

- Classified according to the inner light diameter DN/ID
- Life expectancy is 100 years
- Excellent hydraulic properties
- Excellent chemical stability
- High temperature stability at 60 °C, short term up to 90 °C
- High resistance to abrasion
- Pipes are lightweight

- Easy handling and installation
- Good mechanical properties
- Good impact resistance at low temperatures
- Good pipe flexibility
- Pipes can be completely recycled
- Pipes do not contain heavy metals or other disputed matter
- Friction coefficient is - Kb = 0.25 mm

The pipes are manufactured as class SN4 and SN8, pipes according to customer's request can be produced in class SN12 and SN16

\* In addition to classes SN4 and SN8, pipes can also be produced in classes SN12 and SN16 upon customer request

\*\* The values in the table are mean values measured during continuous product quality control over a long period of time

CODE	DN		OD (mm)	ID (mm)	CWT	LWT	T	A	e
10702000	Ø140	SN4	160.5	140	0.7	0.7	17.4	3.5	11
10702020		SN8	160	139	0.7	0.8	17.4	3.5	11
10702001	Ø200	SN4	228	199	0.9	0.7	22	4.2	1.9
10702021		SN8	228.5	200	1	1.1	22	4.2	2
10702002	Ø250	SN4	284	249	1	0.6	26	4.5	2.2
10702022		SN8	283	248	1.2	1.4	26	4.5	2.3
10702003	Ø300	SN4	341	300	1.7	1.3	34.6	6.8	2.5
10702023		SN8	342	303	1.9	1.5	34.6	6.8	2.8
10702004	Ø400	SN4	455	400	1.8	1.2	50.8	11.9	3
10702024		SN8	454.5	401	2.1	2	50.8	11.9	3.2
10702005	Ø500	SN4	571	503	2	1.5	59	11	3.6
10702025		SN8	570	501	2.2	1.7	59	11	4.1
10702006	Ø600	SN4	686	607	2.4	2.5	70	14	3.7
10702026		SN8	685	607	2.7	2.7	70	14	4.5
10702007	Ø800	SN4	907	802	3.3	3	88.7	34.5	5.6
10702027		SN8	906	800	3.6	3.5	88.7	34.5	6.8

## CONNECTING METHODS

### The pipes are produced in accordance with SRPS-EN13476 and EN1440

Connecting with angle fitting, connecting many pipelines with T branches and connecting over the saddle after grip (SAG).

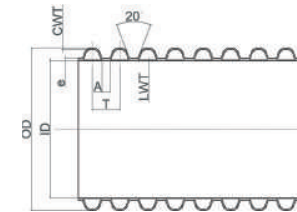

## SADDLE AFTER GRIP (SAG)

**Saddle after grip is new, modern product, with great performance.**

It is intended for subsequent connection to an existing pipeline for smooth as well as corrugated pipes. Using this system, combined with a great range of Peštan fittings, production of new lines of home, street and drain sewer, as well as connecting to existing lines becomes satisfaction.

Peštan latest product main purpose is to be subsequently attached to an existing pipeline with a connection to smooth and corrugated pipes. The connection is safe and waterproof. It is made of ABS by injection molding technology.



## SIZES

Sizes are given in the following table:

K/K CODE	K/SW CODE	
10799210	10799110	250/160
10799211	10799111	300/160
10799212	10799112	400/160
10799213	10799113	500/160
10799214	10799114	600/160
K/K CODE	K/SW CODE	
10799200	10799100	250/200
10799201	10799101	300/200
10799202	10799102	400/200
10799203	10799103	500/200
10799204	10799104	600/200

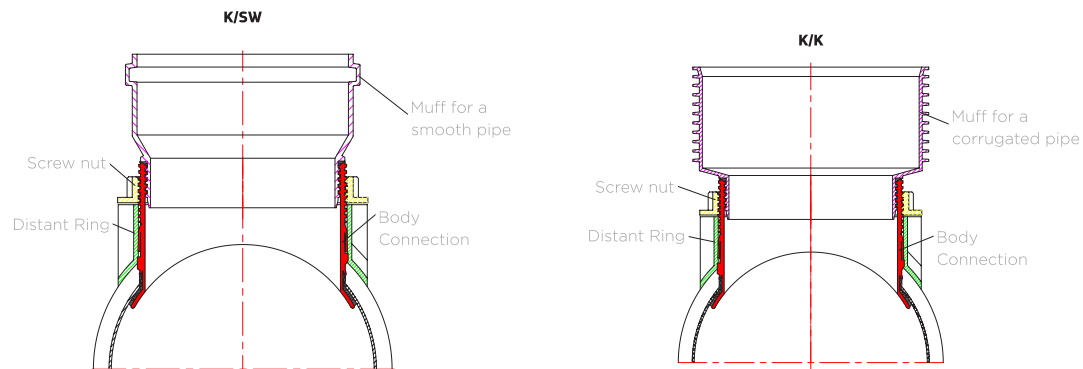



## MONTAGE OF SAG THROUGH PHASES



1. Tools required



2. Determining position for montage



3. Drilling holes for the guided crown saw



4. Drilling holes with crown saw



5. Cleaning chips and forming a clear hole



6. Lubricating rubber bands on the body of sag



7. Inserting body of sag through pre-prepared opening and setting it in the appropriate position



8. setting the spacer ring



9. Tightening the sag



10. Lubricating appropriate connection of sag



11. Setting the selected connection



12. Final tightening of sag

## BENDS 15°, 30°, 45°, 60°, 90°

---

Bends are side fittings which main purpose is connecting pipes at certain angle in accordance with requirements (15°, 30°, 45°, 60°, 90°). It is made in the technology of welding pipe segments and semi joints which has the function of integrated socket.

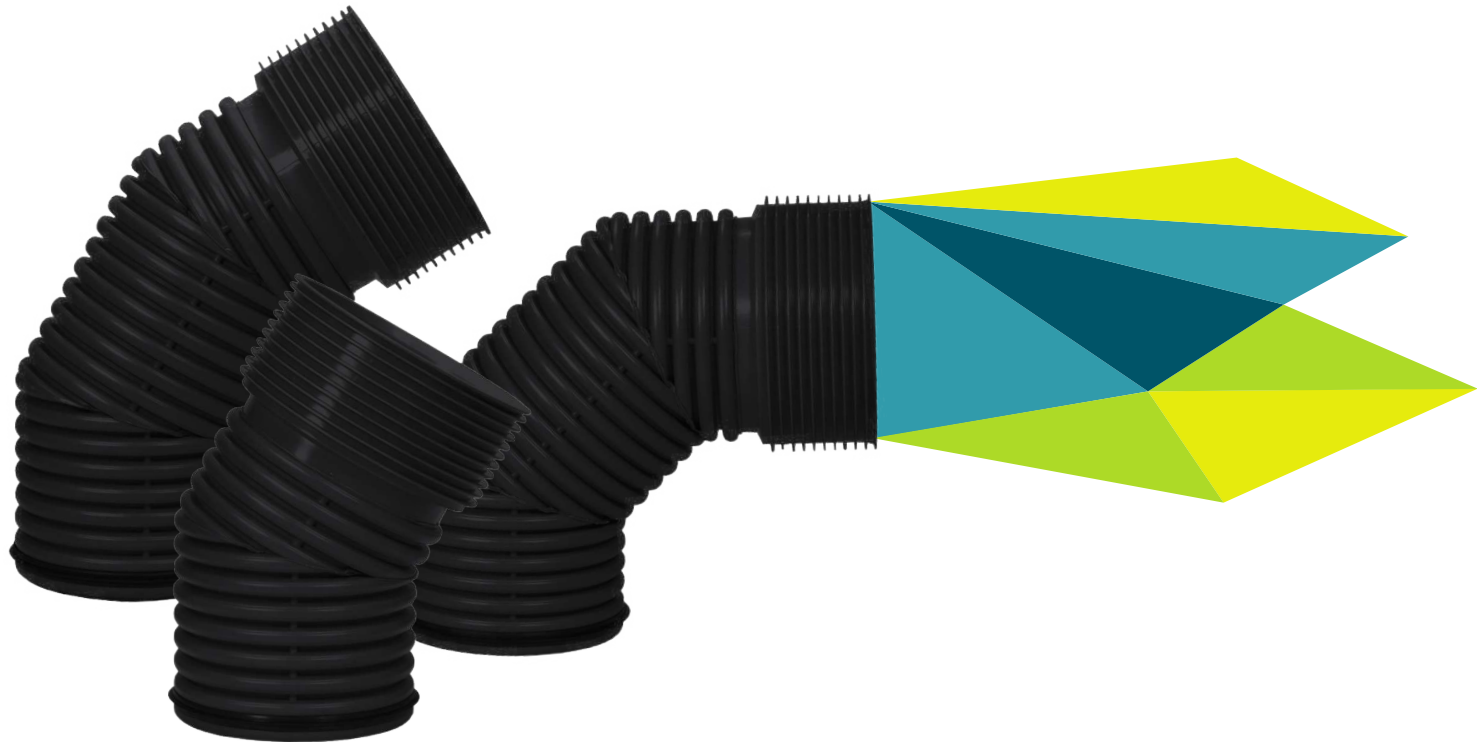

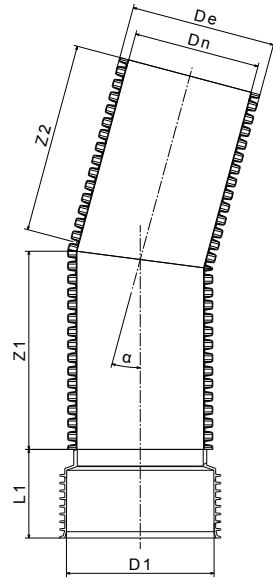

### BEND 15°

CODE	DN	DE	D1	A	L1	Z1	Z2
10799240	140 F/M	160	162	30°	95	180	165
10799521	140 F/F	160	162	30°	95	180	165
10799241	200 F/M	227	230	30°	140	200	180
10799523	200 F/F	227	230	30°	140	200	180
10799242	250 F/M	283	286	30°	170	235	210
10799525	250 F/F	283	286	30°	170	235	210
10799243	300 F/M	340	346	30°	180	280	250
10799527	300 F/F	340	346	30°	180	280	250
10799244	400 F/M	453	458	30°	230	355	315
10799529	400 F/F	453	458	30°	230	355	315
10799245	500 F/M	567	575	30°	255	475	425
10799531	500 F/F	567	575	30°	255	475	425
10799246	600 F/M	680	686	30°	300	595	525
10799533	600 F/F	680	686	30°	300	595	525

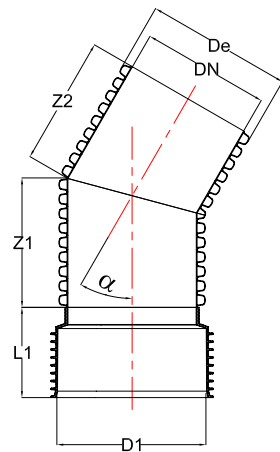

### BEND 30°

CODE	DN	DE	D1	A	L1	Z1	Z2
10799250	140 F/M	160	162	30°	95	180	165
10799561	140 F/F	160	162	30°	95	180	165
10799251	200 F/M	227	230	30°	140	200	180
10799563	200 F/F	227	230	30°	140	200	180
10799252	250 F/M	283	286	30°	170	235	210
10799565	250 F/F	283	286	30°	170	235	210
10799253	300 F/M	340	346	30°	180	280	250
10799567	300 F/F	340	346	30°	180	280	250
10799254	400 F/M	453	458	30°	230	355	315
10799569	400 F/F	453	458	30°	230	355	315
10799255	500 F/M	567	575	30°	255	475	425
10799571	500 F/F	567	575	30°	255	475	425
10799256	600 F/M	680	686	30°	300	595	525
10799573	600 F/F	680	686	30°	300	595	525

Measurements are given in millimeters (mm)

\*F/M - female/male socket  
F/F - female/female socket

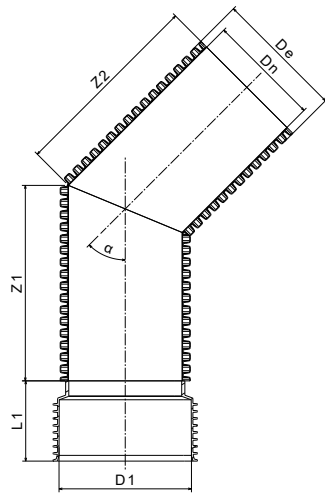

### BEND 45°

CODE	DN	DE	D1	A	L1	Z1	Z2
10799260	140 F/M	160	162	45°	95	210	210
10799586	140 F/F	160	162	45°	95	210	210
10799261	200 F/M	227	230	45°	140	225	225
10799588	200 F/F	227	230	45°	140	225	225
10799262	250 F/M	283	286	45°	170	260	260
10799590	250 F/F	283	286	45°	170	260	260
10799263	300 F/M	340	346	45°	180	315	315
10799592	300 F/F	340	346	45°	180	315	315
10799264	400 F/M	453	458	45°	230	395	395
10799594	400 F/F	453	458	45°	230	395	395
10799265	500 F/M	567	575	45°	255	530	530
10799596	500 F/F	567	575	45°	255	530	530
10799266	600 F/M	680	686	45°	300	660	660
10799598	600 F/F	680	686	45°	300	660	660

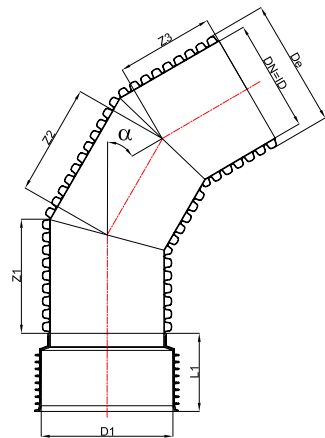

### BEND 60°

CODE	DN	DE	D1	A	L1	Z1	Z2	Z3
10799270	140 F/M	160	162	60°	95	165	210	165
10799611	140 F/F	160	162	60°	95	165	210	165
10799271	200 F/M	227	230	60°	140	180	225	180
10799613	200 F/F	227	230	60°	140	180	225	180
10799272	250 F/M	283	286	60°	170	210	235	210
10799615	250 F/F	283	286	60°	170	210	235	210
10799273	300 F/M	340	346	60°	180	250	285	250
10799617	300 F/F	340	346	60°	180	250	285	250
10799274	400 F/M	453	458	60°	230	315	350	315
10799619	400 F/F	453	458	60°	230	315	350	315
10799275	500 F/M	567	575	60°	255	420	475	420
10799621	500 F/F	567	575	60°	255	420	475	420
10799276	600 F/M	680	686	60°	300	525	595	525
10799623	600 F/F	680	686	60°	300	525	595	525

Measurements are given in millimeters (mm)

\*F/M - female/male socket  
F/F - female/female socket

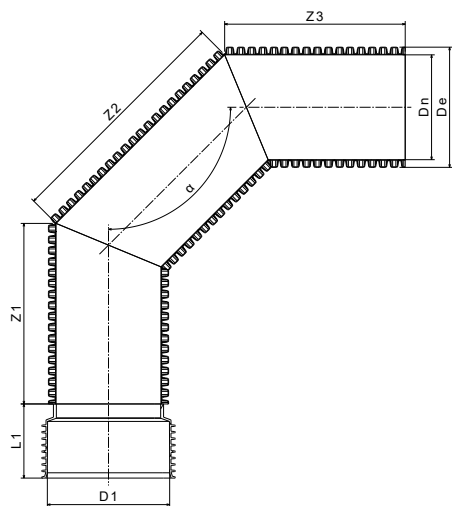

BEND 90°

CODE	DN	DE	D1	A	L1	Z1	Z2	Z3
10799280	140 F/M	160	162	90°	95	165	210	165
10799631	140 F/F	160	162	90°	95	165	210	165
10799281	200 F/M	227	230	90°	140	180	225	180
10799633	200 F/F	227	230	90°	140	180	225	180
10799282	250 F/M	283	286	90°	170	210	260	210
10799635	250 F/F	283	286	90°	170	210	260	210
10799283	300 F/M	340	346	90°	180	250	315	250
10799637	300 F/F	340	346	90°	180	250	315	250
10799284	400 F/M	453	458	90°	230	315	390	315
10799639	400 F/F	453	458	90°	230	315	390	315
10799285	500 F/M	567	575	90°	255	425	530	425
10799641	500 F/F	567	575	90°	255	425	530	425
10799286	600 F/M	680	686	90°	300	525	660	525
10799643	600 F/F	680	686	90°	300	525	660	525

Measurements are given in millimeters (mm)

\*F/M - female/male socket  
F/F - female/female socket

## TEE

---

This fitting was obtained by welding pipe segments at an angle of 90° with the appropriate extension in the form of semi joint. Available for pipe diameters Ø140-Ø600.



## K-BRANCH

---

This fitting was obtained by welding pipe segments at an angle of 45° with the appropriate extension in the form of semi joint. Available for pipe diameters Ø140-Ø600.



## EXCENTRIC REDUCER

---

Fitting which main purpose is connecting pipes of different diameters. It is made of polypropylene injection molding technology. This fitting is available in sizes listed in the table.



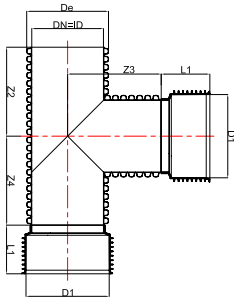

### TEE

CODE	DN	DE	D1	L1	Z2	Z3	Z4
10799350	140 F/M	160	162	91	220	215	220
10799671	140 F/F	160	162	91	220	215	220
10799351	200 F/M	227	230	140	245	245	245
10799673	200 F/F	227	230	140	245	245	245
10799352	250 F/M	283	286	168	285	300	285
10799675	250 F/F	283	286	168	285	300	285
10799353	300 F/M	340	344	182	345	360	345
10799677	300 F/F	340	344	182	345	360	345
10799354	400 F/M	453	458	235	430	460	430
10799679	400 F/F	453	458	235	430	460	430
10799355	500 F/M	567	574	299	580	600	580
10799681	500 F/F	567	574	299	580	600	580
10799356	600 F/M	680	686	310	725	735	725
10799683	600 F/F	680	686	310	725	735	725

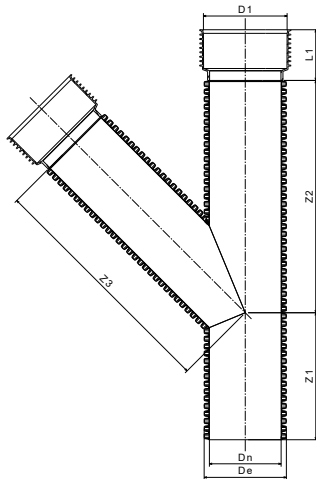

### K-BRANCH

CODE	DN	DE	D1	L1	Z2	Z3	Z4
10799330	140 F/M	160	162	91	220	215	220
10799651	140 F/F	160	162	91	220	215	220
10799333	200 F/M	227	230	140	245	245	245
10799653	200 F/F	227	230	140	245	245	245
10799654	250 F/M	283	286	168	285	300	285
10799655	250 F/F	283	286	168	285	300	285
10799656	300 F/M	340	344	182	345	360	345
10799657	300 F/F	340	344	182	345	360	345
10799658	400 F/M	453	458	235	430	460	430
10799659	400 F/F	453	458	235	430	460	430
10799660	500 F/M	567	574	299	580	600	580
10799661	500 F/F	567	574	299	580	600	580
10799662	600 F/M	680	686	310	725	735	725
10799663	600 F/F	680	686	310	725	735	725

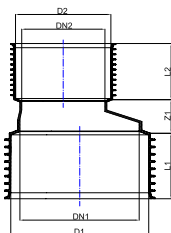

### EXCENTRIC REDUCER

CODE	DN1	DN2	D1	D2	Z1	L1	L2
10799300	200	140	230	160	58	115	91
40000760	250	200	286	230	129	145	110
40000763	300	250	344	286	136	153	137
40000812	400	300	458	344	146	200	150
40000764	500	400	574	458	159	262	200
40000814	600	500	686	574	171	270	262

Measurements are given in millimeters (mm)

\*F/M - female/male socket  
F/F - female/female socket

## TRANSITION FROM CORRUGATED TO SMOOTH PIPE

---

The purpose of this product is transition from smooth to corrugated pipe. It is made of polypropylene injection molding technology or welding. It is available in sizes that are given in the table.



## END CAP

---

This product has a function of closing the pipes and fittings while installing pipes and different types of testing as well as for any other purpose. It is made in the technology of injection molding and welding polypropylene.



## DOUBLE MUFF

---

Fitting designed for linear connection of pipe with same diameter. The product is obtained by polypropylene injection molding.





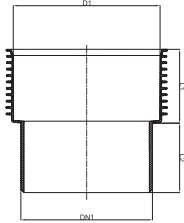

### TRANSITION FROM CORRUGATED TO SMOOTH PIPE

CODE	DN	DN1	D1	L1	L2
10799500	140	160	162	90	90
40000771	200	200	230	115	120
40000772	250	250	286	145	143
40000773	300	315	346	153	155
40000774	400	400	459	235	200

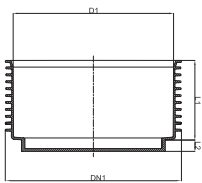

### END CAP

CODE	DN	DN1	D1	L1	L2
10799400	140	176	162	90	25,5
10799401	200	230	200	115	30
10799402	250	286	250	145	31
10799403	300	346	300	153	32
10799404	400	459	400	235	35
10799405	500	624	574	262	37
10799406	600	748	686	270	40

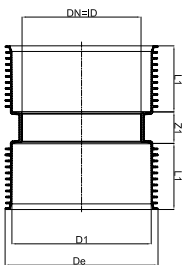

### DOUBLE MUFF

CODE	DN	DE	D1	L1	Z1
10799000	140	176	162	90	51
10799001	200	252	230	115	60
10799002	250	312	286	145	62
10799003	300	375	346	153	64
10799004	400	498	459	200	70
10799005	500	624	575	262	74
10799006	600	748	690	270	80
40000792	800	960	919	325	90

Measurements are given in millimeters (mm)

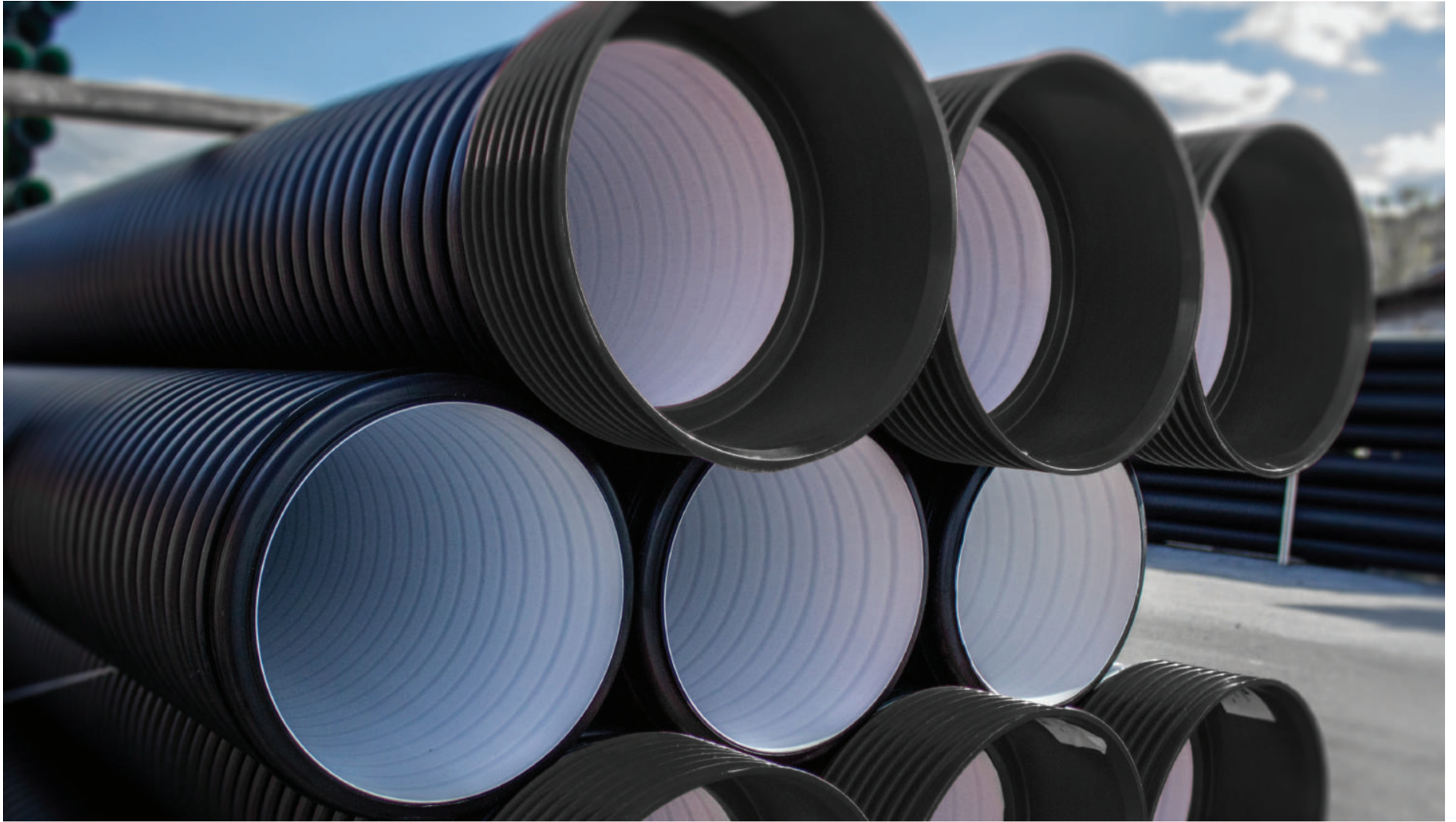

# PP CORUGATED OD PIPES

---



Double layered corrugated PP OD pipes and fittings

## PRODUCTION AND PURPOSES

**Peštan Company supplies for its corrugated pipes only certified materials from top manufacturers.**

These raw materials are satisfying properties of high impact resistance that have polypropylene copolymer PP-B. It is very important to make the correct choice of pipe by the type of fluid and by conditions of exploitation, in accordance with the characteristics of the material from which they are made of.

CHARACTERISTICS	VALUE	EN
Density	900kg/m <sup>3</sup>	EN 1183
MFR	0,3gr/10 min(230/2,16)	EN1133
Modulus of elasticity	1500/2000MPa	EN527
Tensile strength at yield point	32 MPa	EN527
Impact toughness by Sharp with a comma	+23 °C 70kJ/m <sup>2</sup>	EN179/1eA
	-23 °C 7 kJ/m <sup>2</sup>	EN179/1eA



## MATERIAL

**Material properties and temperature application are given in the following table:**

MATERIAL	MIN.	MAX.	SHORT-TERM
PP	-20 °C	60 °C	95 °C
PE-HD	-40 °C	40 °C	70 °C
PVC-U	0 °C	40 °C	60 °C

## PRODUCTION

### Pipes are manufactured in accordance with SRPS-EN13476 and EN1440

- Classified according to outside diameter DN/OD
- Life expectancy is 100 years
- Excellent hydraulic properties
- Excellent chemical stability
- High temperature stability at 60 °C, short term up to 90 °C
- High resistance to abrasion
- Pipes are lightweight
- Easy handling and installation
- Good mechanical properties
- Good impact resistance at low temperatures
- Good pipe flexibility

- Pipes can be completely recycled
- Pipes do not contain heavy metals or other disputed matter
- Friction coefficient is -  $K_b = 0.25$  mm
- Standard length is 6 or 12 m

The pipes are manufactured as class SN4 and SN8, pipes according to customer's request can be produced in class SN12 and SN16.

Pipe diameters from DN 200 up to DN 500 are produced with welded socket. Smaller diameters are produced with double socket already mounted on the pipe.

## CONNECTING METHODS

### The pipes are produced in accordance with SRPS-EN13476 and EN1440

Connecting with angle fitting, connecting many pipelines with T branches and connecting over the saddle after grip (SAG).

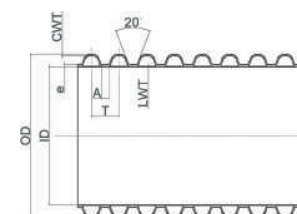

DN (OD) mm		ID (mm)	CWT	LWT	T	A	e
Ø110	SN4	96	0.4	0.5	13.6	4.1	1
	SN8	95	0.5	0.6	13.6	4.1	1.1
Ø125	SN4	109	0.6	0.6	15.2	4.4	1.2
	SN8	108	0.6	0.7	15.2	4.4	1.3
Ø160	SN4	138	0.6	0.7	20	5.4	1.3
	SN8	137	0.7	0.8	20	5.4	1.4
Ø200	SN4	177	1	0.7	19.3	6	1.5
	SN8	175	1.1	0.8	19.3	6	1.8
Ø250	SN4	221	1.2	0.8	30.1	6.5	1.6
	SN8	220	1.5	1	30.1	6.5	2.2
Ø315	SN4	272	1.6	0.7	35	8.8	2
	SN8	270	2	1.2	35	8.8	3.1
Ø400	SN4	345	1.8	1.3	49	11.7	2
	SN8	343	2	1.5	49	11.7	3.5
Ø500	SN4	430	1.8	1.7	58	19.4	3.8
	SN8	428	2	1.8	58	19.4	5.2
Ø630	SN4	547	2	2.1	71.2	25	5.4
	SN8	545	2.3	2.3	71.2	25	6.3

\* The values in the table are mean values measured during continuous product quality control over a long period of time

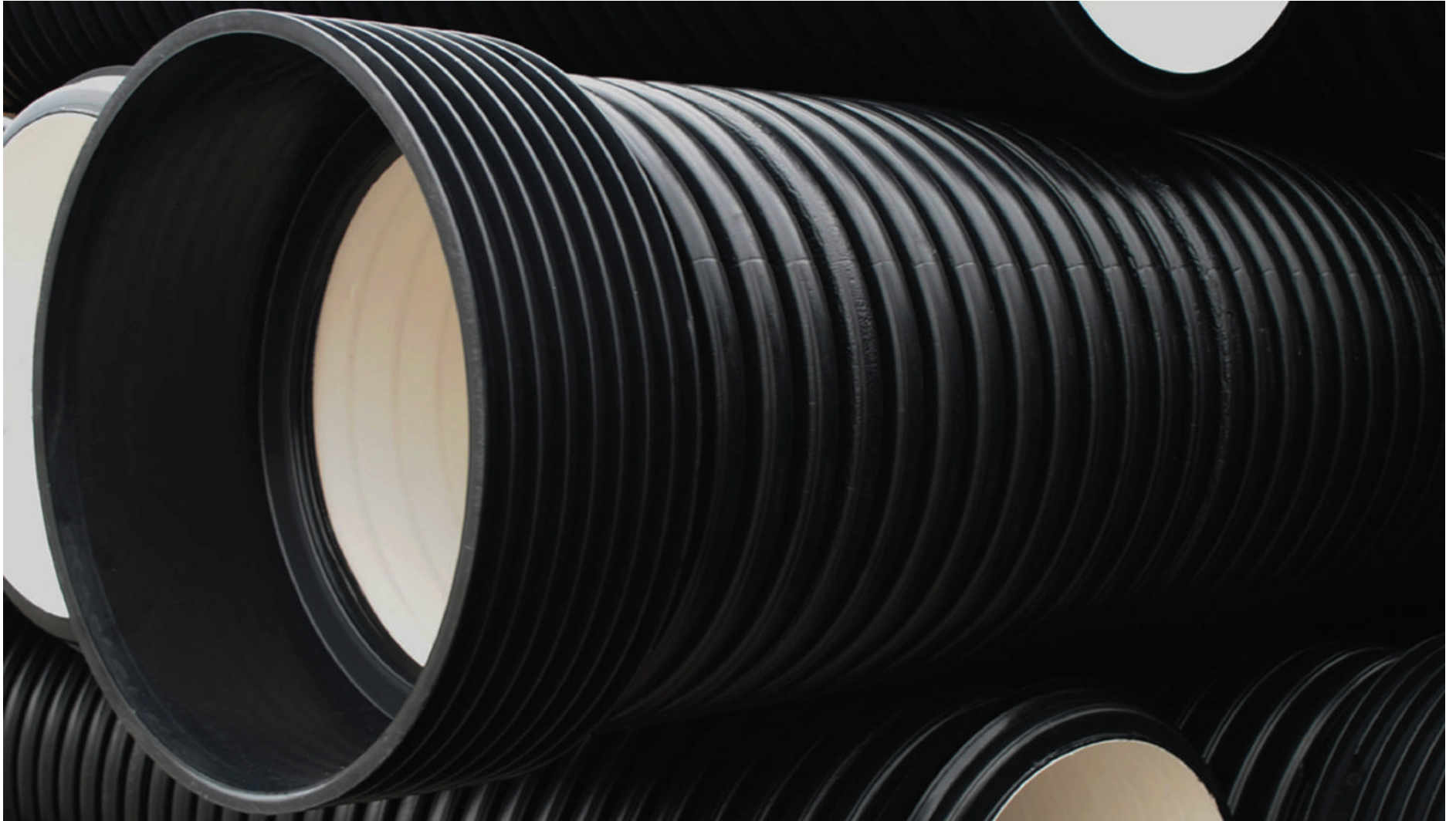

# HDPE CORRUGATED ID PIPES



For domestic & street sewage systems

## HDPE CORRUGATED PIPES FOR SEWERAGE SYSTEM

---

**Connection method is via the socket with rubber which is inserted into the third channel of corrugated pipe between the ribs and the lubricated socket is pulled over the rubber on tube. Pipes can be shortened by ordinary knife or saw, and all the pieces of pipe can be used as extensions.**

HDPE pipes are lighter than PVC pipes for the same purpose, allowing easier handling and installation, and they have excellent chemical resistance to aggressive environment and the surrounding soil. Laying and using of HDPE pipelines is between  $-40\text{ }^{\circ}\text{C}$  to  $+60\text{ }^{\circ}\text{C}$ . The smooth inner surface has a low coefficient of friction so the pipes have very good hydraulic characteristics. They have excellent resistance to abrasion and excellent mechanical and physical properties.

Pipes are resistant to UV rays, and can stand in the open for an year. Beyond that period they should be protected. During transportation and installation, protection must be ensured by keeping the pipes away from sharp edges because they can damage the pipe while they are very resistant to the impacts with a blunt object. The pipes are certified by the Institute for Materials of Republic of Serbia.

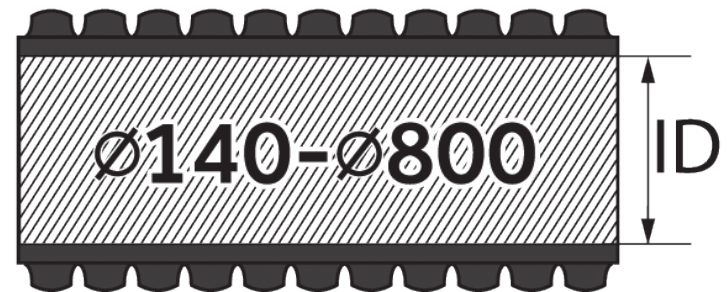



## FEATURES AND SPECIFICATIONS

---

- Material: PE-HD (polyethylene high-density)
- Pipes can be embed at a depth of at least 0.8 m to 8m max. Concrete protection is required above 0.8 m
- Quick and cheap installation
- Ring stiffness SN=4 KN/m<sup>2</sup> and SN=8 KN/m<sup>2</sup>
- Standard length is 6 or 12 m, or coil 50 + 100 m
- Standard color is black and can be different by demand
- Standard packing: Ø110-Ø200 Bar 6 and 12 m, or coil 50 i 100 m Ø250-Ø315 bar 6 and 12 m

## INSTALLATION

---

### INSTALLATION OF PIPES

The pipes must be professionally installed respecting the appropriate guidelines specified by standard 1610 and DIN4033, which means that in an area of the pipeline from the bottom of the trench to at least 30 cm above the vertex, following compression values should be achieved.

### ACCORDING TO PROCTOR:

- All values should be proven during operation
- 97% density of shoveled land for non-bonding soil
- 95% density of unshoveled land for bonding soil

DN /ID (nominal diameter is inside diameter) double layer corrugated HDPE pipes are classified by the inner diameter of the pipe.

They are made without integrated socket, and connection is achieved through the sockets made of the same material.

Range of production is from  $\varnothing 140$ - $\varnothing 800$  with ring stiffness of sn4 and sn8, and even stronger by special order.

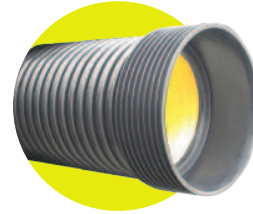

ID SN4

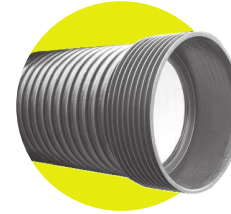

ID SN8

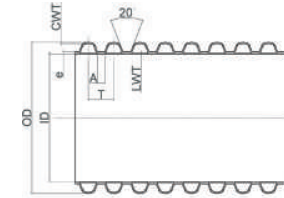

DN		OD (mm)	ID (mm)	CWT	LWT	T	A	e
Ø140	SN4	160.5	140	0.7	0.7	17.4	3.5	1.1
	SN8	160	139	0.7	0.8	17.4	3.5	1.1
Ø200	SN4	228	199	0.9	0.7	22	4.2	1.9
	SN8	228.5	200	1	1.1	22	4.2	2
Ø250	SN4	284	249	1	0.6	26	4.5	2.2
	SN8	283	248	1.2	1.4	26	4.5	2.3
Ø300	SN4	341	300	1.7	1.3	34.6	6.8	2.5
	SN8	342	303	1.9	1.5	34.6	6.8	2.8
Ø400	SN4	455	400	1.8	1.2	50.8	11.9	3
	SN8	454.5	401	2.1	2	50.8	11.9	3.2
Ø500	SN4	571	503	2	1.5	59	11	3.6
	SN8	570	501	2.2	1.7	59	11	4.1
Ø600	SN4	686	607	2.4	2.5	70	14	3.7
	SN8	685	607	2.7	2.7	70	14	4.5
Ø800	SN4	907	802	3.3	3	88.7	34.5	5.6
	SN8	906	800	3.6	3.5	88.7	34.5	6.8

\* The values in the table are mean values measured during continuous product quality control over a long period of time

## COUPLING ELEMENTS AND FITTINGS

An integral part of any piping system are the various joints, branches and manholes. Peřtan products and the entire program of coupling elements and fittings. These include: Branches, Bends, Reducers, Drain manholes, End caps, Couplings.

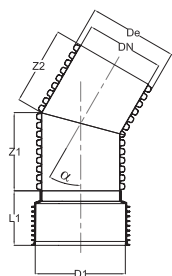

BEND 30°

DN	DE	D1	$\alpha$	L1	Z1	Z2
140	160	162	30°	95	180	165
200	227	230	30°	140	200	180
250	283	286	30°	170	235	210
300	340	346	30°	180	280	250
400	453	458	30°	230	355	315
500	567	575	30°	255	475	425
600	680	686	30°	300	595	525

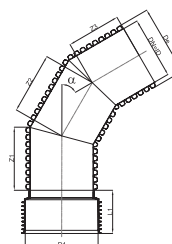

BEND 60°

DN	DE	D1	$\alpha$	L1	Z1	Z2	Z3
140	160	162	60°	95	165	210	165
200	227	230	60°	140	180	225	180
250	283	286	60°	170	210	235	210
300	340	346	60°	180	250	285	250
400	453	458	60°	230	315	350	315
500	567	575	60°	255	420	475	420
600	680	686	60°	300	525	595	525

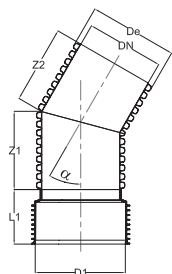

BEND 45°

DN	DE	D1	$\alpha$	L1	Z1	Z2
140	160	162	45°	95	210	210
200	227	230	45°	140	225	225
250	283	286	45°	170	260	260
300	340	346	45°	180	315	315
400	453	458	45°	230	395	395
500	567	575	45°	255	530	530
600	680	686	45°	300	660	660

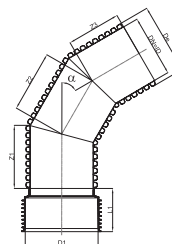

BEND 90°

DN	DE	D1	$\alpha$	L1	Z1	Z2	Z3
140	160	162	90°	95	165	210	165
200	227	230	90°	140	180	225	180
250	283	286	90°	170	210	260	210
300	340	346	90°	180	250	315	250
400	453	458	90°	230	315	390	315
500	567	575	90°	255	425	530	425
600	680	686	90°	300	525	660	525

### TEE

DN	DE	D1	L1	Z2	Z3	Z4
140	160	162	91	220	215	220
200	227	230	140	245	245	245
250	283	286	168	285	300	285
300	340	344	182	345	360	345
400	453	458	235	430	460	430
500	567	574	299	580	600	580
600	680	686	310	725	735	725

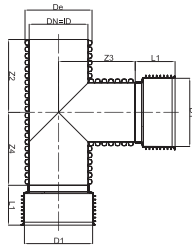

### EXCENTRIC REDUCER

DN1	DN2	D1	D2	Z1	L1	L2
200	140	230	160	58	115	91
250	200	286	230	129	145	110
300	250	344	286	136	153	137
400	300	458	344	146	200	150
500	400	574	458	159	262	200
600	500	686	574	171	270	262

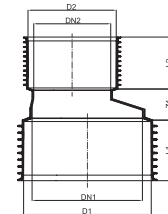

### TRANSITION FROM CORRUGATED TO SMOOTH PIPE

DN	DN1	D1	L1	L2
140	160	162	90	90
200	200	230	115	120
250	250	286	145	143
300	315	346	153	155
400	400	459	235	200

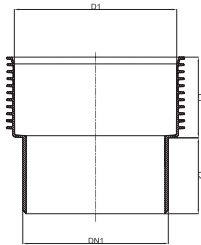

### END CAP

DN	DN1	D1	L1	L2
140	176	162	90	25,5
200	230	200	115	30
250	286	250	145	31
300	346	300	153	32
400	459	400	235	35
500	624	574	262	37
600	748	686	270	40

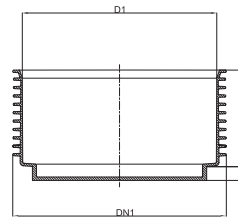

### DOUBLE MUFF

DN	DE	D1	L1	Z1
140	176	162	90	51
200	252	230	115	60
250	312	286	145	62
300	375	346	153	64
400	498	459	200	70
500	624	575	262	74
600	748	690	270	80
800	960	919	325	90

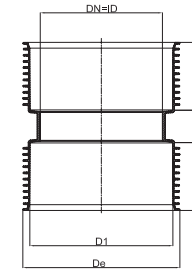





# HDPE CORRUGATED OD PIPES

---

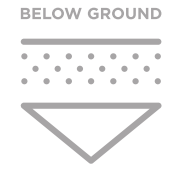

For street sewage systems

## HDPE CORRUGATED PIPES FOR SEWERAGE SYSTEM

---

**Connection method is via the socket with rubber which is inserted into the third channel of corrugated pipe between the ribs and the lubricated socket is pulled over the rubber on tube. Pipes can be shortened by ordinary knife or saw, and all the pieces of pipe can be used as extensions.**

HDPE pipes are lighter than PVC pipes for the same purpose, allowing easier handling and installation, and they have excellent chemical resistance to aggressive environment and the surrounding soil. Laying and using of HDPE pipelines is between  $-40\text{ }^{\circ}\text{C}$  to  $+60\text{ }^{\circ}\text{C}$ . The smooth inner surface has a low coefficient of friction so the pipes have very good hydraulic characteristics. They have excellent resistance to abrasion and excellent mechanical and physical properties.

Pipes are resistant to UV rays, and can stand in the open for an year. Beyond that period they should be protected. During transportation and installation, protection must be ensured by keeping the pipes away from sharp edges because they can damage the pipe while they are very resistant to the impacts with a blunt object. The pipes are certified by the Institute for Materials of Republic of Serbia.





## FEATURES AND SPECIFICATIONS

- Material: PE-HD (polyethylene high-density)
- Pipes can be embed at a depth of at least 0.8 m to 8 m max. Concrete protection is required above 0.8 m
- Quick and cheap installation
- Ring stiffness SN = 4 KN/m<sup>2</sup> and SN = 8 KN/m<sup>2</sup>
- Standard length is 6 or 12 m, or coil 50 + 100 m
- Standard color is black and can be different by demand
- Standard packing:  
Ø110-Ø200 Bar 6 and 12 m, or coil 50 i 100 m Ø250-Ø315 bar 6 and 12 m



## PACKAGING AND INSTALLATION

### INSTALLATION OF PIPES

The pipes must be professionally installed respecting the appropriate guidelines specified by standard 1610 and DIN4033, which means that in an area of the pipeline from the bottom of the trench to at least 30 cm above the vertex, following compression values should be achieved.

### ACCORDING TO PROCTOR:

- All values should be proven during operation
- 97% density of shoveled land for non-bonding soil
- 95% density of unshoveled land for bonding soil

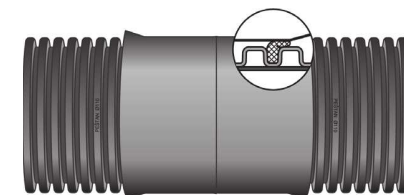

CONNECTING THE PIPE WITH THE SOCKET

HDPE corrugated pipes defined by the outer diameter (DN/OD) DN/OD (nominal diameter is outside diameter) double layer corrugated HDPE pipes are classified by the outer diameter of the pipe.

They are made without integrated socket, and connection is achieved through the sockets made of the same material.

Range of production is from Ø140-Ø500 with ring stiffness of SN4 and SN8, and even stronger by special order.

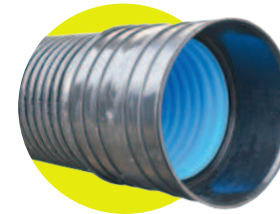
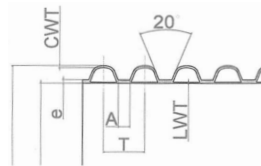

OD SN4

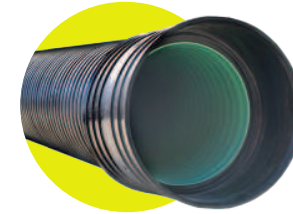

OD SN8

DN		OD (mm)	ID (mm)	CWT	LWT	T	A	e
Ø140	SN4	160.5	140	0.7	0.7	17.4	3.5	1.1
	SN8	160	139	0.7	0.8	17.4	3.5	1.1
Ø200	SN4	228	199	0.9	0.7	22	4.2	1.9
	SN8	228.5	200	1	1.1	22	4.2	2
Ø250	SN4	284	249	1	0.6	26	4.5	2.2
	SN8	283	248	1.2	1.4	26	4.5	2.3
Ø300	SN4	341	300	1.7	1.3	34.6	6.8	2.5
	SN8	342	303	1.9	1.5	34.6	6.8	2.8
Ø400	SN4	455	400	1.8	1.2	50.8	11.9	3
	SN8	454.5	401	2.1	2	50.8	11.9	3.2
Ø500	SN4	571	503	2	1.5	59	11	3.6
	SN8	570	501	2.2	1.7	59	11	4.1
Ø600	SN4	686	607	2.4	2.5	70	14	3.7
	SN8	685	607	2.7	2.7	70	14	4.5
Ø800	SN4	907	802	3.3	3	88.7	34.5	5.6
	SN8	906	800	3.6	3.5	88.7	34.5	6.8

\* The values in the table are mean values measured during continuous product quality control over a long period of time





**PPSTRONG**  
pipes and fittings

Proven **strenght**.  
High level of **durability**.

# PP STRONG

---

Compact high strength Polypropylene pipes



# PP STRONG pipes and fittings

---

Peštan PP Strong pipes and fittings are produced of PP material by the newest technology of pipe extrusion and fitting injection. PP STRONG pipe system for all kinds of waste water is made as homogeneous fully-walled pipe without mineral additives with extremely smooth inner surface according to EN 1852.

Both pipe and fitting in the PP STRONG range are intended for areas with great static pressure, such as airports, highways and railroads. PP STRONG system is universal and can be used for removing all types of waste waters in low construction.

Installation and manipulation of the pipeline elements is very simple and is described in the following chapters of this technical manual. Pipes are connected with fittings, while the waterproofing in connections is provided by rubber rings (safety lock) made of EPDM rubber with plastic reinforcement. Inner layer of PP STRONG pipe is very smooth, which results with excellent hydraulic characteristics, high resistance to abrasion, and preventing subsidence on inner layer of the pipe.

PP STRONG pipes are resistant to corrosion and their life span is 50 years if used properly.

PP STRONG pipes are resistant to corrosion and their life span is 50 years if used properly.

Pipes and fitting have excellent thermal stability and are resistant to:

- Short term exposure up to 90 °C
- Continuous thermal exposure up to 60 °C

Chemical resistance of PP STRONG:

Salt water, alcohol, acids, alkali, sulphates, aggressive gases and all kinds of detergents. They are well suited for drainage of aggressive chemical wastes, Ph values between 2 and 12.

PP STRONG is sensitive to waste waters that contain high percentage of gasoline, benzene and acetone. For detailed chemical resistance of pipeline please consult the table on our web page.

Fittings are 100% resistant to leaking up to the pressure of 0.5bar with usage of classic rubber ring of EPDM rubber. While using the special safety lock rubber with plastic reinforcement, leaking resistance goes up to 2bar short term.

Pipes aren't intended for outside appliance because of the instability to UV radiation. PP STRONG is intended for underground appliance and under great loads.

Do not install the pipeline in temperature below -10 °C.

PP STRONG goes under the B2 class of fire stability by standard DIN 4102, they belong to the group of normal burning materials.

#### CHARACTERISTICS:

- Absolute impermeability
- Minimal wasting
- Stable functioning during the whole life span of the pipe
- Higher ring stiffness
- Higher longitudinal rigidity
- Available pipe with coupling or with integrated socket
- High ring flexibility

#### ADVANTAGES:

- Wide range of fittings
- Great resistance to static and dynamic pressures
- Great resistance to work damage
- High impact resistance
- Without mineral additives
- Stability to chemical and thermal pressure
- Very tight lock in connections
- Very long term life

#### FIELDS OF APPLIANCE:

- Communal drainage
  - New buildings or replacements of old sewage
- Chemical and machine industry
  - Excellent chemical stability (pH 2-12)
- Food industry
  - Great stability to temperatures and cycle work resistance
  - Stability to cleaning products
- Roads
  - Great resistance to static and dynamic loads and pressures

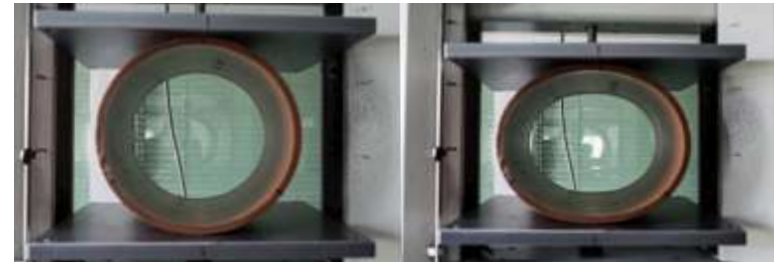

Pipes withstand deformations up to 30% to inner diameter. According to EN ISO 13968



BENOR

· INSTA-CERT ·

# PP STRONG pipes

---

Peštan PP STRONG pipes and fittings are produced in:

-Diameters Ø110 to Ø500

-Ring stiffnesses SN4, SN8, SN10, SN12, SN16 in accordance EN1852

PP STRONG pipes are produced in standard lengths 1 - 6m.

PP STRONG in classes SN4, SN8, SN10 and SN12 are produced with socket, while class SN16 are produced with integrated coupling.

PP STRONG coupling stiffness class is SN16 and as such resistant to big static pressures.

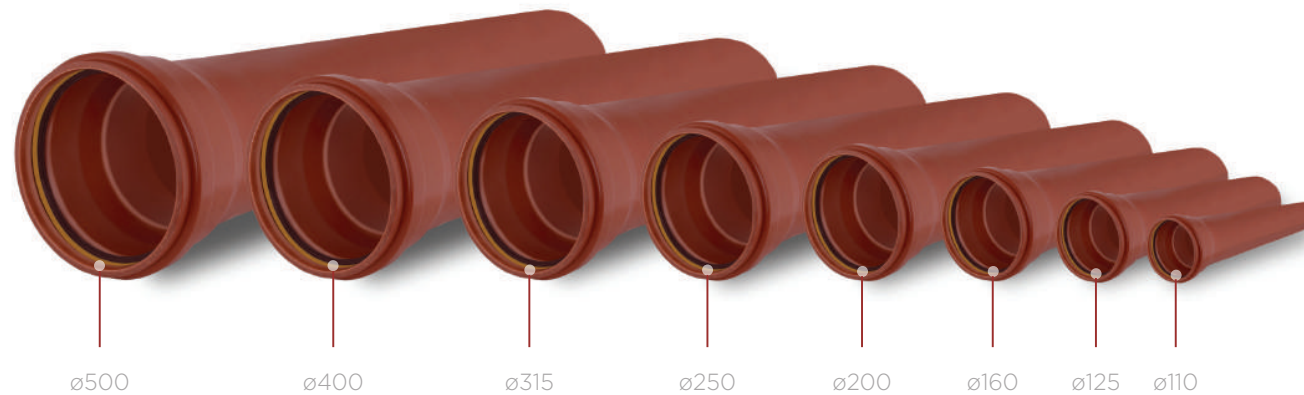



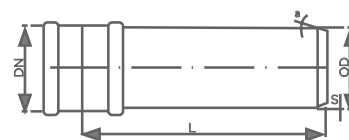
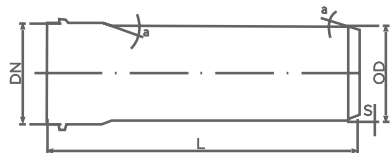

SN 4			SN 8			SN 10			SN 12			SN 16		
DN [mm]	S [mm]	L [mm]	DN [mm]	S [mm]	L [mm]	DN [mm]	S [mm]	L [mm]	DN [mm]	S [mm]	L [mm]	DN [mm]	S [mm]	L [mm]
110	3,4	1000	110	3,8	1000	110	4,2	1000	110	4,5	1000	110	5	1000
		3000			3000			3000			3000			3000
		6000			6000			6000			6000			6000
125	3,9	1000	125	4,3	1000	125	4,8	1000	125	5,1	1000	125	5,7	1000
		3000			3000			3000			3000			3000
		6000			6000			6000			6000			6000
160	4,9	1000	160	5,5	1000	160	6,2	1000	160	6,5	1000	160	7,3	1000
		3000			3000			3000			3000			3000
		6000			6000			6000			6000			6000
200	6,2	1000	200	6,9	1000	200	7,7	1000	200	8,1	1000	200	9,1	1000
		3000			3000			3000			3000			3000
		6000			6000			6000			6000			6000
250	7,7	1000	250	8,6	1000	250	9,6	1000	250	10,2	1000	250	11,4	1000
		3000			3000			3000			3000			3000
		6000			6000			6000			6000			6000
315	9,7	1000	315	10,8	1000	315	12,1	1000	315	12,8	1000	315	14,4	1000
		3000			3000			3000			3000			3000
		6000			6000			6000			6000			6000
400	12,3	1000	400	13,7	1000	400	15,4	1000	400	16,3	1000	400	18,2	1000
		3000			3000			3000			3000			3000
		6000			6000			6000			6000			6000
500	15,3	1000	500	17,1	1000	500	19,2	1000	500	20,3	1000	500	22,8	1000
		3000			3000			3000			3000			3000
		6000			6000			6000			6000			6000

# PP STRONG pipes with integrated socket

---

The tubes are produced in ring stiffness of: SN4, SN8, SN10, SN12.

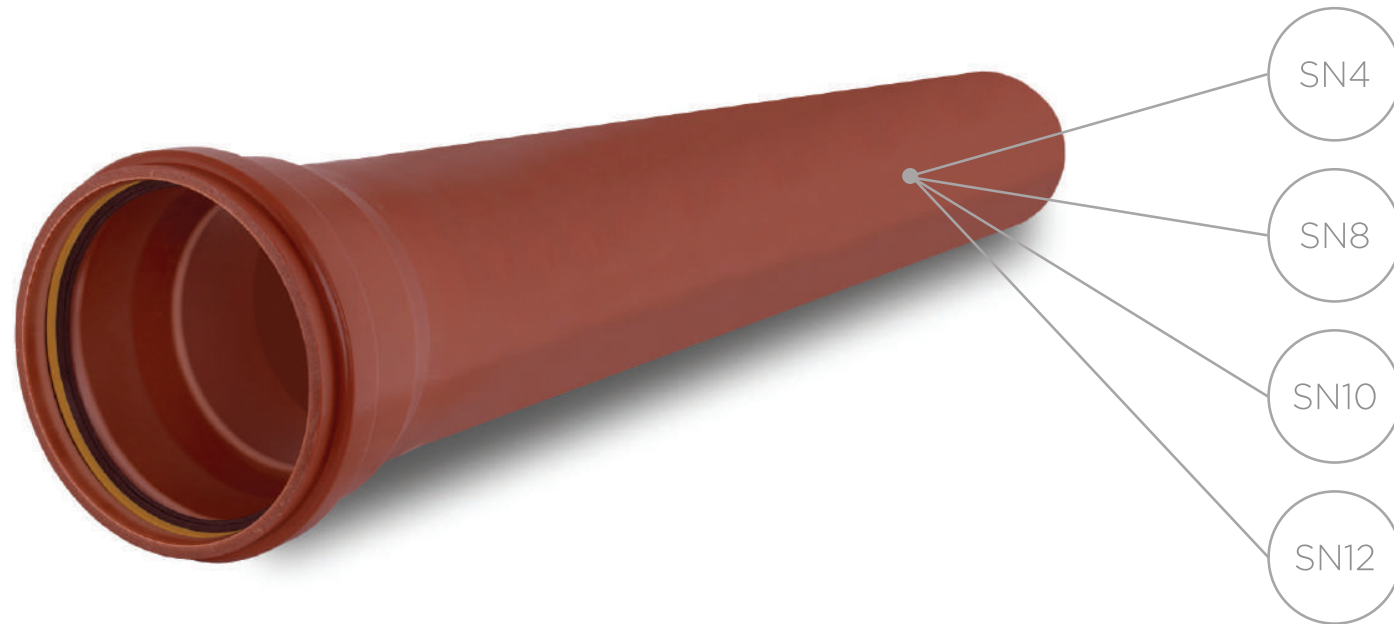

SDR 20,6 SN12				
DN/OD	e min	A min	B min	d <sup>3</sup> min
110	4,5	40	6	120,3
125	5,1	43	7	137,1
160	6,5	50	9	173,8
200	8,1	58	12	215,6
250	10,2	68	18	272,9
315	12,8	81	20	338,9
400	16,3	98	24	427,1
500	20,3	118	28	533,2

SDR 33 SN 4				
DN/OD	e min	A min	B min	d <sup>3</sup> min
110	3,4	40	6	120,3
125	3,9	43	7	137,1
160	4,9	50	9	173,8
200	6,2	58	12	215,6
250	7,7	68	18	272,9
315	9,7	81	20	338,9
400	12,3	98	24	427,1
500	15,3	118	28	533,2

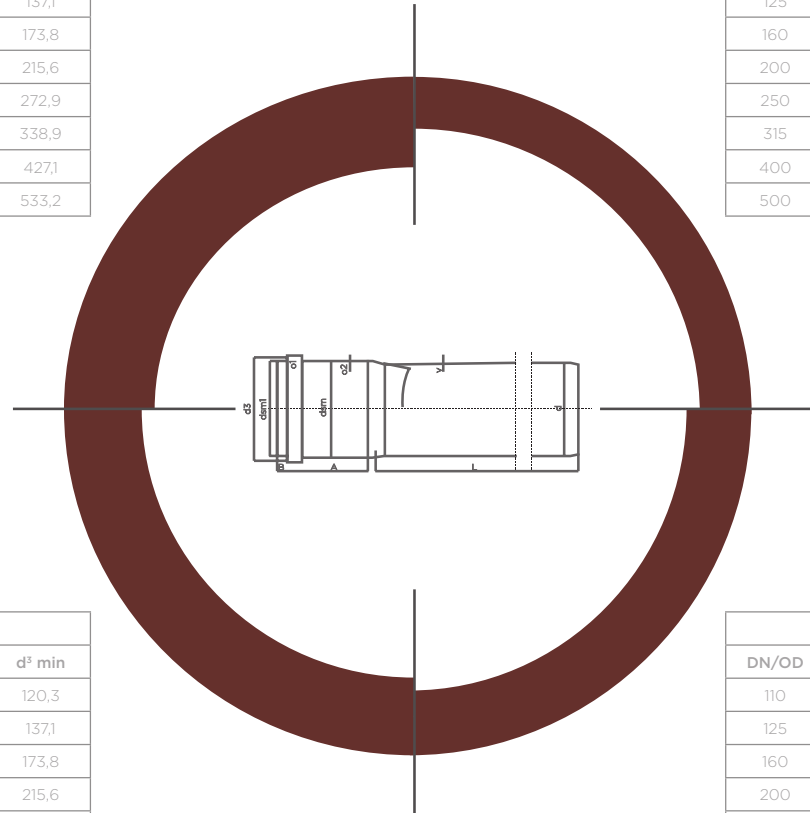

SDR 33 SN 4				
DN/OD	e min	A min	B min	d <sup>3</sup> min
110	4,2	40	6	120,3
125	4,8	43	7	137,1
160	6,2	50	9	173,8
200	7,7	58	12	215,6
250	9,6	68	18	272,9
315	12,1	81	20	338,9
400	15,4	98	24	427,1
500	19,2	118	28	533,2

SDR 33 SN 4				
DN/OD	e min	A min	B min	d <sup>3</sup> min
110	3,8	40	6	120,3
125	4,3	43	7	137,1
160	5,5	50	9	173,8
200	6,9	58	12	215,6
250	8,6	68	18	272,9
315	10,8	81	20	338,9
400	13,7	98	24	427,1
500	17,1	118	28	533,2

# PP STRONG pipes with coupling

---

The tube is produced in ring stiffness of: SN16

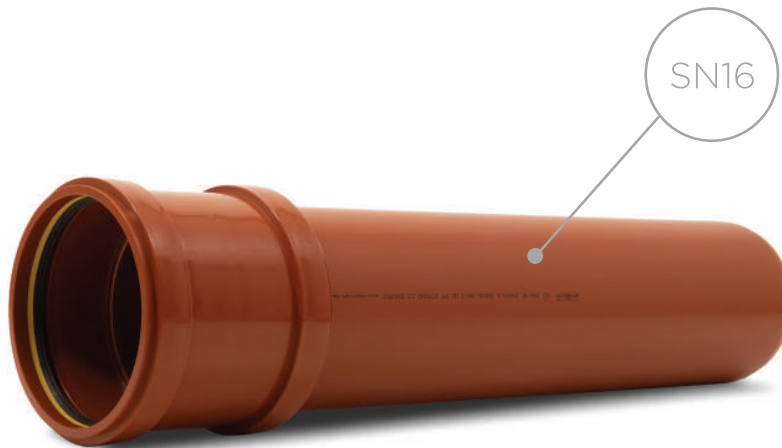

SDR 22 SN 16				
DN/OD	e min	A min	B min	d <sup>3</sup> min
110	5	40	6	120,3
125	5,7	43	7	137,1
160	7,3	50	9	173,8
200	9,1	58	12	215,6
250	11,4	68	18	272,9
315	14,4	81	20	338,9
400	18,3	98	24	427,1
500	22,8	118	28	533,2

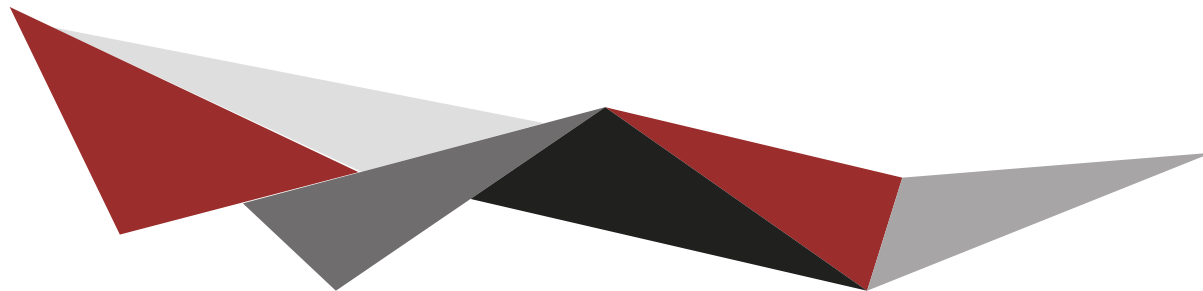

# Class and pipe stiffness

SN 4	S 16	SDR 33
SN 8 S	14	SDR 29
SN 10	S 12,5	SDR 26
SN 12	S 11,8	SDR 24,6
SN 16	S 10,5	SDR 22

Material characteristics	Value	Standard
Density	900 kg/m <sup>3</sup>	ISO 1183
MFR (230 °C/2,16 kg)	≤1,5 g/10 min	ISO 1183
Internal pressure test (80 °C, 4,2 MPa)	» 140 h	ISO 1167-1
Internal pressure test (95 °C, 2,5 MPa)	» 1000 h	ISO 1167-2
Rensile Strain at Yield (50 mm/min)	6,5 %/33 MPa	ISO 527-1 ISO 527+2
Charpy Impact Strength (23 °C/-20 °C)	29/2 kJ/m <sup>2</sup>	ISO 179/1 eA
Ring stiffness, SN	4, 8, 10, 12, 16	ISO 9969
Chemical resistance	2.. 12 pH	ISO/TR 10 358
Temperature resistance (short term/longterm)	90/60 °C	
Temperature conductivity	0,2 W/mK	DIN 52612
Linear coefficient of stretching	0,14 mm/Km	DIN 52328
Module of elasticity	2000 MPa	ISO 178
Connection technique	Socket and rubber	
Rubber ring	Rubber ring with plastic strengthened in different color and with closing surfaces	





# PP STRONG fittings

---

Within the Peštan production program there is a complete fitting program made in diameters from Ø110 to Ø315 produced in ring stiffness of SN8 (S13.3) while fittings Ø110, Ø160, Ø200, Ø400 are produced in ring stiffness of SN4 (S16).

The couplings are produced in the class SN16 (S10.5) in all dimensions.



· INSTA-CERT ·

BENOR





**Rubber rings** are made of EPDM rubber with plastic reinforcement



**PP Strong** fitting marking

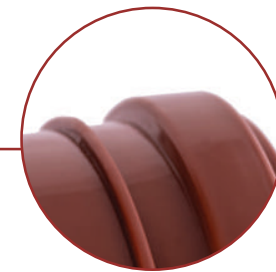

**Reinforced ribs** for higher fitting strength

Fittings class according to EN 1852 standard

DN/OD	Minimum wall thickness		
	SN 2 S 20 SDR 41	SN 4 S 16 SDR 33	SN 8 S 13,3 SDR 27,6
110	-	3,4	4,0
125	-	-	4,6
160	-	4,9	5,8
200	-	5,2	7,3
250	6,2	7,7	9,1
315	7,7	9,7	11,4
400	9,8	12,3	
Value $e_{min}$ according to ISO 4065			



EN 1852 (SDR 27,6) - SN8							
mm	DN 110	DN 125	DN 160	DN 200	DN 250	DN 315	DN 400
Dem (mm)	110,0	125,0	160,0	200,0	250	315,0	400,0
e min (mm)	4,0	4,6	5,8	7,3	9,1	11,4	14,5
D3 min (mm)	120,3	137,1	173,8	215,6	272,9	338,9	427,1
B min (mm)	6	7	9	12	18	20	24
A min (mm)	40	43	50	58	68	81	98
L1 min (mm)	62	68	82	98	118	144	178

EN 1852 (SDR 22) - SN 16								
mm	DN 110	DN 125	DN 160	DN 200	DN 250	DN 315	DN 400	DN 500
Dem (mm)	110,4	125,4	160,5	200,6	250,9	316,0	401,2	501,5
e min (mm)	4,5	5,2	6,6	8,2	10,3	11,3	16,4	16,4
D3 min (mm)	120,3	137,1	173,8	215,6	272,9	338,9	427,1	533,2
B min (mm)	6	7	9	12	18	20	24	28
A min (mm)	40	43	50	58	68	81	98	118

SDR 33 S16 SN4						
DN/OD	dem	dsm <sub>min</sub>	e <sub>min</sub>	A <sub>min</sub>	C <sub>max</sub>	L1 <sub>min</sub>
110	110.0 <sup>+0.4</sup>	110.4	3.4	40	22	62
160	160.0 <sup>+0.5</sup>	160.5	4.9	50	32	82
200	200.0 <sup>+0.5</sup>	200.6	6.2	58	40	98

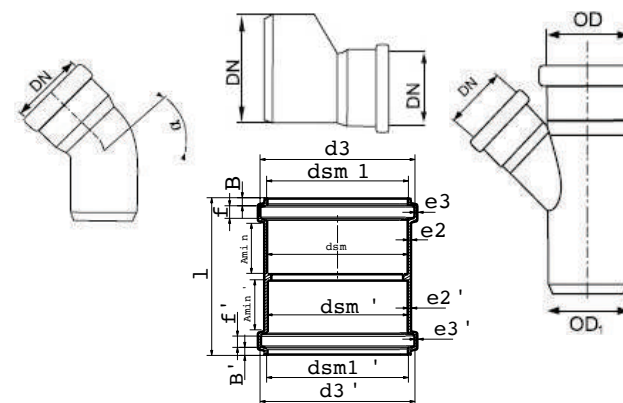

SDR 33 S16 SN4						
DN/OD	dem	dsm <sub>min</sub>	e <sub>min</sub>	A <sub>min</sub>	C <sub>max</sub>	L1 <sub>min</sub>
110	110.0 <sup>+0.4</sup>	110.4	4.0	40	22	62
125	125.0 <sup>+0.4</sup>	125.4	4.6	43	26	68
160	160.0 <sup>+0.5</sup>	160.5	5.8	50	32	82
200	200.0 <sup>+0.5</sup>	200.6	7.3	58	40	98
250	250.0 <sup>+0.5</sup>	250.8	9.1	68	70	118
315	315.0 <sup>+0.6</sup>	316.1	11.4	81	70	144
400	400.0 <sup>+0.7</sup>	403.7	14.5	98	80	178
500	500.0 <sup>+0.9</sup>	504.6	18.1	118	80	218



PP STRONG BEND				
	DN [mm]	ANGLE [°]	S 13,3	S 16
	110	15	✓	✓
		30	✓	✓
		45	✓	✓
		67,5	✓	—
		87,5	✓	✓
	125	15	✓	—
		30	✓	—
		45	✓	—
		67,5	✓	—
		87,5	✓	—
	160	15	✓	✓
		30	✓	✓
		45	✓	✓
		67,5	✓	—
		87,5	✓	✓
	200	15	✓	✓
30		✓	✓	
45		✓	✓	
67,5		✓	—	
87,5		✓	✓	
250	15	✓	—	
	30	✓	—	
	45	✓	—	
	67,5	✓	—	
	87,5	✓	—	
315	15	✓	—	
	30	✓	—	
	45	✓	—	
	67,5	✓	—	
	87,5	✓	—	
400	45	✓	—	
	87,5	✓	—	

PP STRONG BRANCH				
	DN [mm]	ANGLE [°]	S 13,3	S 16
	110/110	45	✓	✓
		87,5	✓	✓
	125/125	45	✓	—
		87,5	✓	—
	160/110	45	—	✓
		87,5	—	✓
	160/160	45	✓	✓
		87,5	✓	✓
	200/160	45	✓	✓
		87,5	✓	✓
	200/200	45	✓	✓
		87,5	✓	✓
	250/160	45	✓	—
		87,5	✓	—
	250/200	45	✓	—
		87,5	✓	—
	250/250	45	✓	—
		87,5	✓	—
	315/160	45	✓	—
		87,5	✓	—
315/200	45	✓	—	
	87,5	✓	—	
315/250	45	✓	—	
	87,5	✓	—	
315/315	45	✓	—	
	87,5	✓	—	
400/160	45	✓	—	
400/200	45	✓	—	

PP STRONG DOUBLE SOCKET			
	DN [mm]	S 13,3	S 16
	110	✓	✓
	125	✓	—
	160	✓	✓
	200	✓	—
	250	✓	—
	315	✓	—
	400	✓	—
	500	✓	—

PP STRONG SLEEVE SOCKET			
	DN [mm]	S 13,3	S 16
	110	✓	✓
	125	✓	—
	160	✓	✓
	200	✓	—
	250	✓	—
	315	✓	—
	400	✓	—
	500	✓	—

PP STRONG REDUCTION			
	DN [mm]	S 13,3	S 16
	160/110	—	✓
	200/160	✓	✓
	250/200	✓	—
	315/250	✓	—
	400/200	✓	—

■ **KGF Flood gate  
for manhole.  
For smooth PP,  
PVC and PE pipes.  
Class S13.3 SN8**

The ribs on the fitting  
provide a connection  
between the concrete  
manhole and the KGF  
element. →

Ø315

Ø250

Ø200

Ø160

Ø125

Ø110





10203680	PVC KGF FLOOD GATE ø110
10203681	PVC KGF FLOOD GATE ø125
10203682	PVC KGF FLOOD GATE ø160
10203683	PVC KGF FLOOD GATE ø200
10203684	PVC KGF FLOOD GATE ø250
10203685	PVC KGF FLOOD GATE ø315
11502908	KGF FLOOD GATE Ø400 WELDED
11502909	KGF FLOOD GATE Ø500 WELDED

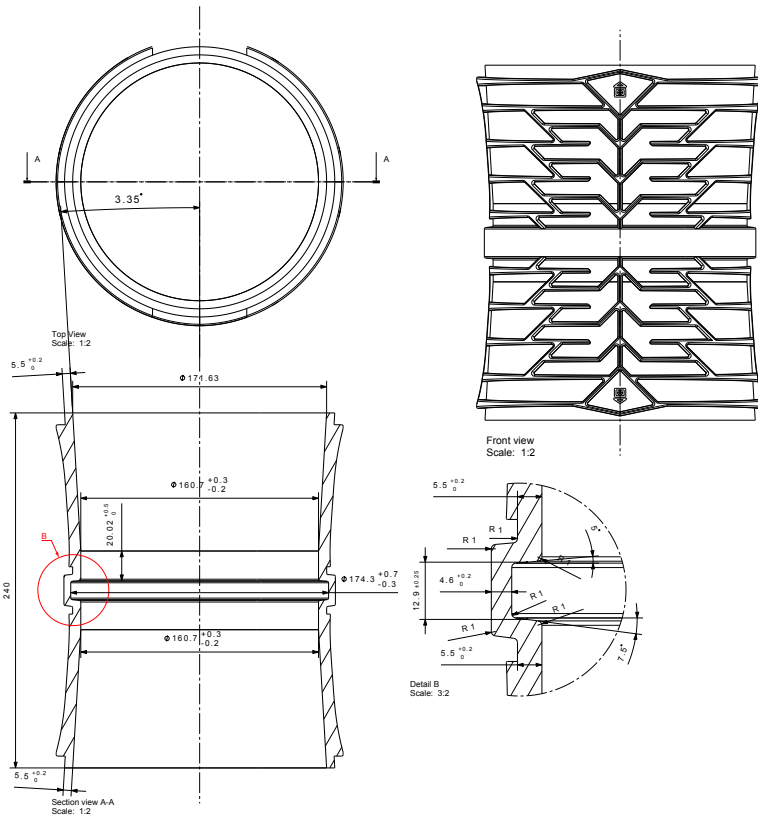

Internal slope 3%  
(interior fitting) →



# Packaging of pipes and fittings

---

Peštan PP Strong pipes and fittings are packaged in transport packages (unit and pallet) in a way favorable to customers. The packaging ensures the customer safety during storage and easy handling with the same.

Pipes in lengths of 1m all up to 6m are packed in packages which, depending on the diameter and length, contain a certain number of pieces both in unit packaging and whole packages.



*The look of packed package with 3 frames*

*Note:*

*For exact information on the dimensions of the package and the number of pieces on unit and transport package, contact Peštan on email: [office@pestan.net](mailto:office@pestan.net)*



Standard packages of coupling elements (fittings) are in cardboard packaging in specified dimensions, which represent unit packages.

**Transport and manipulation:**

Peštan PP Strong pipes and all connecting elements should be transported with appropriate transport vehicles. The loading area of the transport vehicle must be solid, flat, without sharp protrusions and without any waste parts (both on the floor and on all sides of the inner part of the transport vehicle). The dimensions of the pallets and packages are such that the loading space of the vehicle is maximally filled.

When it comes to loading pipes outside the transport package, the pipes must rest on a flat surface with their entire length in order not to cause deformation of the pipes. The couplers must therefore be alternately rotated and pulled out for their entire length. This should primarily be taken into account with the pipe of large lengths, because for them improper handling it can come to bending at their ends.

When loading and unloading both pipes and fittings should be handled with care, they should not be thrown, pulled, pushed, especially on concrete and other rough surfaces.

**Note:**

When manipulating and transporting at the temperatures of less than 0 °C, be especially careful to avoid striking stresses in order to avoid mechanical damage to pipes and fittings.

**Storage:**

Peštan Strong PP fittings, which are packed in a cardboard packaging, are stored exclusively indoors (preferably, one pallet - one pallet place). If there is no regal warehouse, it is recommended that this type of transport packaging is stored in a closed space on a flat surface and in one level (do not place a pallet on the pallet).

The transport packaging should be stored in a dry, clean and closed environment with temperatures between 10 and 30°C and a relative humidity between 50 and 60%. Packages should be protected from the direct influence of sunlight, moisture and heat. When the pipe warehouse outdoors they should be protected from direct influence of sunlight with UV protective foil or eaves.

Also, when storing, the pipes must not be stored near the heated surfaces and should be kept in mind not to come in contact with fuels, solvents.

Also, when storing pipes under the pipe, lay wooden billets so that the joints at the ends of the pipe do not rely on the surface and therefore deform.

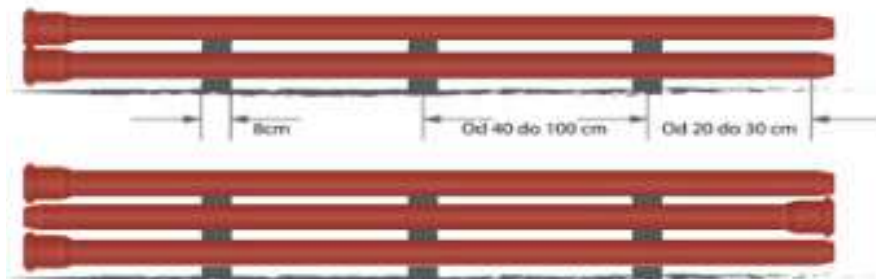

# Installation and connection

Peštan Strong PP pipes and fittings are installed in accordance with EN 1601 Gravity drainage system of street sewers.

If there is a specific regulation within certain countries which deviates from the above mentioned norms, be sure to consult Peštan technical support before installing the system.

## introduction

The first step in the design of sewage systems is geotechnical investigations along the entire route of the pipeline, while the most important condition for achieving a satisfactory pipe installation systems interactions of the pipe and the surrounding soil. The greatest support for embedded pipes gives the soil around the lower half of the pipe in both directions. Therefore, it is very important what kind of soil is done by laying as well as a procedure that is done in the field of soil compaction around the pipe.

## Cutting

Connection of the PP Strong sewage elements are interconnected with rubber sockets for the SN4, SN8, SN10 and SN12 pipes that provide a watertight base of elements, while in the pipe class SN16 pipes connect with other elements via the SN16 class coupling.

All pipes and fittings have a socket coupling in at least one end. Pipes can be cut either with a special pipe section or with a handsaw.

When cutting pipe, cutting must be carried out perpendicular to the axis of the tube, the cut end must be clean and skew.

The table can find the necessary fixings in relation to the diameter of the pipe.

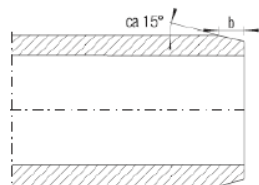

View the required punctuation

DN/OD	b [mm]
110	7
125	7
160	9
200	10
250	14
315	17
400	20
500	23

### Connecting pipes and fittings

When connecting pipes and fittings, all steps must be taken to ensure a secure connection to avoid leaking due to further installation and subsequent use.

In order to connect pipes and fittings, it takes a few steps to execute before that:

1. Clean the pipe fitting and straight end of the pipe.
2. After cleaning the pipes and fittings, check the condition of the sealing elements.
3. After cleaning the check of the condition of the sealing elements, it is necessary to lubricate the flat end of the pipe and the rubber fitting. Peštan lubricants are recommended for this purpose. Lubricants based on oil must not be used. Socket and the sealing rubber bands must be dry and clean. They must also be lubricated.

### Laying pipe in a trench

Peštan Strong PP pipes can be placed in a relatively loose ground. When laying the pipes must be taken into account that in places where the socket coupling or the section is deeper so that coupling aligns along its length, and when it does not disturb the drop tube. Illustrated explanation is below.



When laying pipes and fittings on steep sections, measures should be taken due to the operation of the longitudinal force. In practice, this is most often achieved by the production of concrete resistor blocks.

### Filling and compacting

The filling (30 cm above the tube's head) is followed in layers. Lightweight and medium compacting devices can be used up to 1 m covering. Heavy machines can only be used afterwards.

The filling material must be compacted in layers of thickness from 10 to 30cm, and the required thickness of the overtemperature is:

- Minimum 15cm for diameter DN > 400
- Minimum 30cm for diameter DN < 400

For these surfaces, a minimum compression of the main overflow of 90% is required according to the modified Procter's Density.

### Installation of flood prevention device - non-return valve

When installing a PP strong pipeline, the designer can foresee the installation of a non-return valve on certain sections. In places where there is the possibility of returning water from the street sewer to the facilities, as well as preventing the entry of rodents and other animals through the pipeline. Non-return valves are equipped with automatic valves for closing the flow of water and are opposite to the intended flow of water.

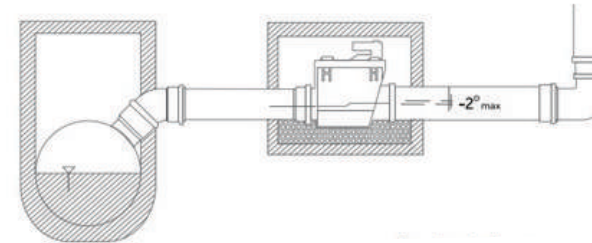

### SAG - Saddle After Grip

SAG - Saddle After Grip is used for subsequent connection to the existing pipeline and in combination with PP Strong pipes gives quick and easy solution. The joint is safe and waterproof, which is provided by the EPDM rubber on the inside of SAG.

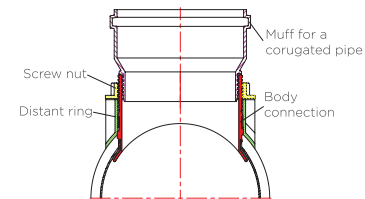



Possibility of making drain manholes of diameter Ø315 and Ø400 of PP Strong pipes.





# PVC ULTRA

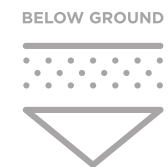

Pipes for a modern sewerage system - PVC ULTRA SN 10, SN 12 i SN 16

## PEŠTAN PVC ULTRA SEWERAGE SYSTEM

---

PEŠTAN PVC ULTRA is a modern sewerage system, which exceeds most of the products of company Peštan.

Peštan development team, after years of research, has developed a new system of sewerage pipes, higher quality and more innovative than previously offered.

ULTRA system (which is a synonym for ultra-modern, innovation and quality) is complementing the existing PP STRONG system, but is based on the PVC as basic raw material.

Peštan PVC ultra are 3-layer sewerage pipes with ring stiffness SN 12. Pipes are produced and tested in accordance with EN 1401. These pipes have a diameter from DN160 to DN400 and have extruded socket which, unlike double sockets or sleeve sockets, reduces possibility of leaks of pipeline for 100%.

### PURPOSE

---

The purpose of these pipes is in field of high static load such as airports, highways and railways. Pipes can be used in areas where there are underground water.

	DN	D1	S	LENGTH (M)						D2	D3	E	F1	U	LB
				1	2	3	4	5	6						
SN10	160	160.4	4,7	✓	✓	✓	✓	✓	✓	160.3	174.4	12.5	12.5	50.8	75.9
	200	200	5,9	✓	✓	✓	✓	✓	✓	200.4	216.3	15.7	13.6	60.3	89.5
	250	250	7,3	✓	✓	✓	✓		✓	250.4	272.8	19.8	20.9	72.4	112.9
	300	315	9,2	✓	✓	✓	✓	✓	✓	315.5	339	24.9	22.8	87.8	135.5
	400	400	11,7	✓	✓	✓	✓	✓	✓	400.7	427.1	31.6	25.7	108.4	165.5
	500	500	14,6	✓	✓	✓	✓	✓	✓	500.7					
	630	630	18,4	✓	✓	✓	✓	✓	✓	630.8					

	DN	D1	S	LENGTH (M)						D2	D3	E	F1	U	LB
				1	2	3	4	5	6						
SN12	160	160	5,5	✓	✓	✓	✓	✓	✓	160.4	174.4	12.5	12.5	50.8	75.9
	200	200	6,7	✓	✓	✓	✓	✓	✓	200.5	216.3	15.7	13.6	60.3	89.5
	250	250	8,1	✓	✓	✓	✓		✓	250.5	272.8	19.8	20.9	72.4	112.9
	300	315	10,5	✓	✓	✓	✓	✓	✓	315.6	339	24.9	22.8	87.8	135.5
	400	400	12,7	✓	✓	✓	✓	✓	✓	400.8	427.1	31.6	25.7	108.4	165.5
	500	500	16,7	✓	✓	✓	✓	✓	✓	500.8					
	630	630	20,7	✓	✓	✓	✓	✓	✓	630.9					

	DN	D1	S	LENGTH (M)						D2	D3	E	F1	U	LB
				1	2	3	4	5	6						
SN16	160	160	6,1	✓	✓	✓	✓	✓	✓	160.5	174.4	12.5	12.5	50.8	75.9
	200	200	7,7	✓	✓	✓	✓	✓	✓	200.6	216.3	15.7	13.6	60.3	89.5
	250	250	9,6	✓	✓	✓	✓		✓	250.6	272.8	19.8	20.9	72.4	112.9
	300	315	12,1	✓	✓	✓	✓	✓	✓	315.7	339	24.9	22.8	87.8	135.5
	400	400	15,4	✓	✓	✓	✓	✓	✓	400.8	427.1	31.6	25.7	108.4	165.5
	500	500	19,2	✓	✓	✓	✓	✓	✓	500.8					
	630	630	24,2	✓	✓	✓	✓	✓	✓	630.9					



## PVC ULTRA

Compared to other plastics suitable for the manufacture of pipes, PVC is characterized by a high modulus of elasticity and good crack resistance. Excellent impact resistance of Pestan PVC Ultra system allows installation at temperatures as low as -10 °C. Pipes can be used to distribute hot water to a maximum of 60 °C.

Pipes carry a label with snowflake in accordance with EN 1401. The pipes are tested in accordance with EN 744 and EN 1411, which unlike of EN 1401 go a step further. This standard stipulates the release of metal weight of 8 kg with a height of at least one meter to the pipe, at a temperature of -10 °C (for diameter DN160).

Since there were no cracks or deformation as result of testing of Pestan PVC Ultra, the mark of snowflake is allowed to be used on pipes. This test simulates the real situation on the construction site where large pieces of stone can fall onto the pipe until it is in a trench.

CHARACTERISTIC	REQUESTS	TESTING PARAMETERS	TEST METHOD
impact resistance (method stairs)	H50 ≥ 1 m Max. A layout below 0,5 m	Test/temperature/ type of stroke	-10 °C ø90 in accordance with EN 1411:1996
		Stroke mass for:	
		dn = 110 mm	4 kg
		dn = 125 mm	5 kg
		dn = 160 mm	8 kg
		dn = 200 mm	10 kg
dn = 250 mm	12,5 kg		
			EN 1411:1996

1. Bar code, 2. Peštan logo, 3. Material, 4. Diameter, 5. Wall thickness, 6. Dimensions according to standard EN 1401, 7. Date and time of manufacture, 8. Snowflake (Installation at low temperatures)



In socket, the rubber ring is placed, with two sealing surfaces and additional short plastic ring that is made in a different color. Rubber ring has a unique design that rubber parts and plastic manufactures together in order to obtain a sealing element. Soft plastic armature allows easy installation of ring, by bending inside to the place where the four notches. After that very easily corrected to the previous position thanks to the notches on the plastic part

Rubber ring is firmly mounted in the socket of the pipe making seal through whole pipe and eliminating many disadvantages of other types of rubber. The sealing rubber is mounted in socket of pipe and so reaches the customer. When the two pipes are connected, the rubber ring is designed to be deformed to a real pressure on the sleeve and the pipe and thus achieves an ideal combination. The pressure in the tubes can vary. The pressure in the pipes may vary, and in these conditions rubber ring must follow these deformations.

Design of rubber ring facilitates the worker installation in a trench, and it is impossible to drop the eraser or turned upside down, so that the risk of incorrect assembly practically does not exist. All that is needed is to lubricate the pipe ring. Opening modes have been designed so that it requires very little force to setup, alignment and connection of the pipes, reducing the risk of shifting of ring, even larger diameters even larger diameters can be connected without special tools and equipment to connect. Pipes fittings can be connected together easily and quickly.

## THE INTERSECTION OF PVC ULTRA PIPES

---

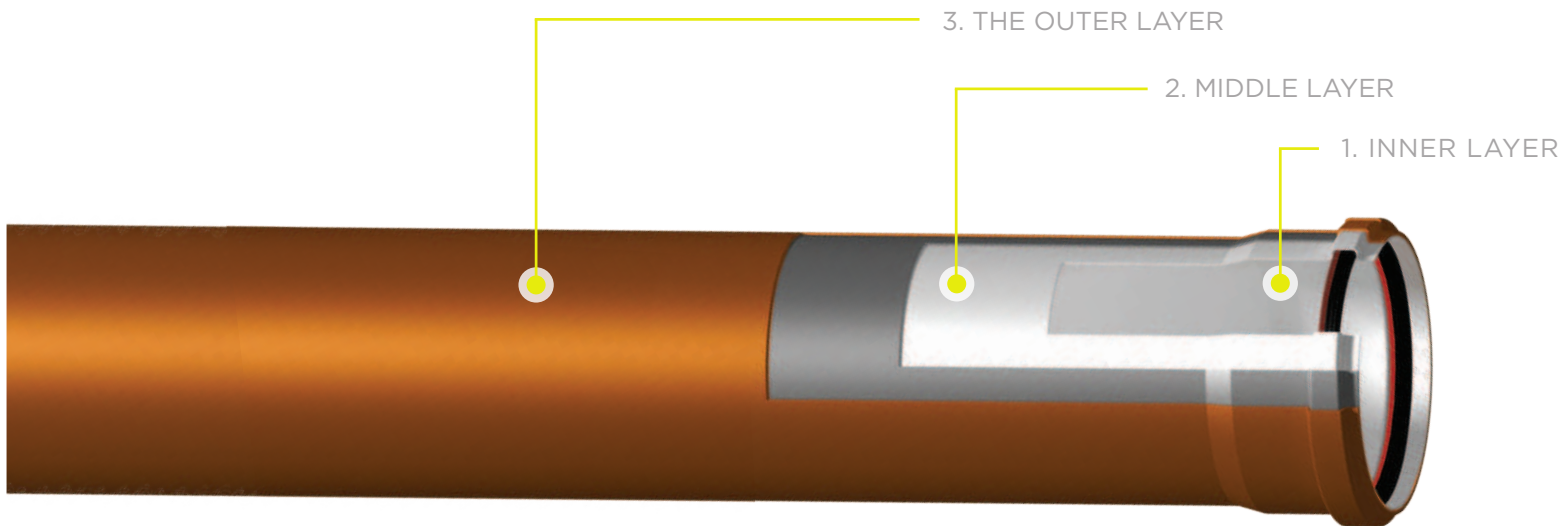

### 1. INNER LAYER:

White color provides a better reflection when shooting camera

### 2. MIDDLE LAYER:

Gray filled with additional mineral reinforced  
It absorbs blows Increases static of pipes

### 3. THE OUTER LAYER:

Dark orange colour  
Shockproof to stone



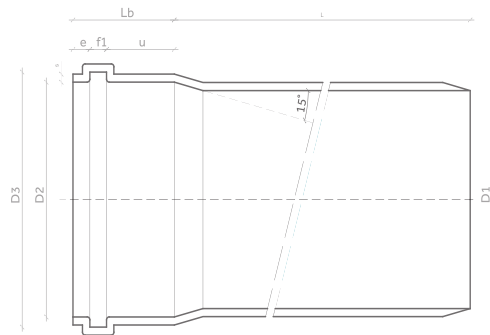

PARAMETER	CHARACTERISTICS
Material	polyvinyl chloride (PVC)
The structure of the pipe	Three-layer compact PVC pipes
The ring stiffness of the pipe	SN 10, SN 12, SN 16
Dostupne dužine cevi	1, 2, 3, 4, 5, 6 metara
Seal	Rubber and plastic reinforcement in a different color and with two sealing surfaces
The temperature when installing	minimum -10 °C, maximum 50 °C
Compacting soil during assembly	90 % - 98 % PS
The depth of the liner	min. 0,5 m, max. 10 m (on the basis of a detailed statistical calculation)

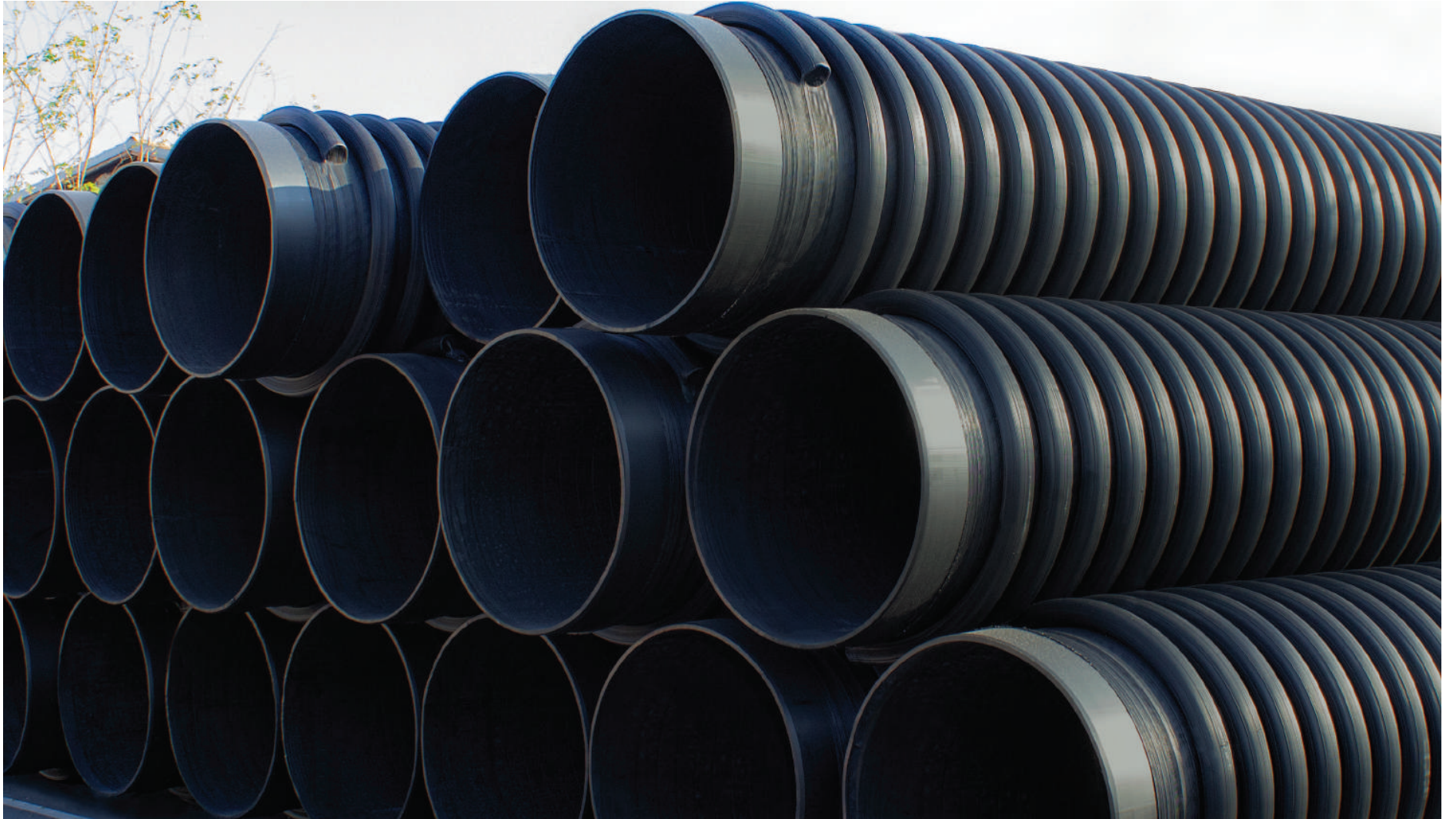

# PE AND PP SPIRAL PIPES - SPIROPIPE

---

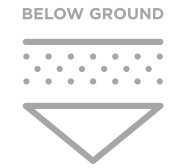

For street sewage systems

Spiral pipes are two-layer corrugated pipes made of high-density polyethylene and consist of an inner smooth wall and external corrugated spiral wall.

## PE SPIRAL PIPES - SPIROPIPE

---

Spiral pipes are two-layer corrugated pipes made of high-density polyethylene and consist of an inner smooth wall and external corrugated spiral wall. The tube is produced by winding profiled outer layer reinforcement of high density polyethylene with corrugated profile on a smooth inner layer that is extruded and welded in continuity.

The outer layer consists of smaller ribs high-intensity hose coated with polyethylene, and the inner layer consists of high-density polyethylene. Presence of profiled hose in the outer layer significantly improves the strength of the pipe itself. Production technology makes possible different steps (profiles) during the winding of the profiled outer layer, which provides different pipe stiffness.

For this reason, PEŠTAN spiral corrugated pipes can be produced in different classes of stiffness.



## CONSTITUTIVE PROPERTY OF MATERIALS

---

- Resistance of crack

High stress crack resistance, even at low temperatures, which is a feature of this materials, guarantees compactness and the stiffness of products that are fully made out of the best quality materials. Reference procedure for the determination of impact resistance is a EN 744.

- Better hydraulic characteristics

Inner diameter and hydraulic characteristics of Peštan PE and PP SPIRAL SPIROPIPE remain the same over the time, regardless of the type of profile, thanks to the strong reduced roughness and low adhesion of the inner pipe walls. The nominal diameter corresponds to the effective inner diameter of the pipe, with tolerances allowed according to reference standards.

- UV resistance

Black polyethylene pipes are resistant to atmospheric effects and UV radiation, thanks to the addition of soot which is equally scattered on a polymeric basis. So such tubes can be used and stored outdoors, for an appropriate period of time, without damaging the material.

Blue pipes are partially resistant to UV radiation and they can be stored outdoors, but in limited period of time (up to 6 months).

- Physical properties of materials PE

- The density 959 gr/cm<sup>3</sup>, according to ISO 1183
- Modulus of stretching 1050 MPa, according to ISO 527
- MRS Classification 10 MPa, according to ISO12162
- Impact strength to Sharpie 23 MPa, according to ISO 179
- Vicat softening temperature 71 °C, according to ISO 306
- Coefficient of linear thermal elongation of 0.13 mm/m °C

- Physical properties of materials PP

- The density 900 gr/cm<sup>3</sup>, according to ISO 1183
- Modulus of stretching 1300 MPa, according to ISO 527
- Tensile load 28 MPa, according to ISO 527
- Impact strength to Sharpie 70 kJ/m<sup>2</sup>, according to ISO 179

- Chemical resistance of materials

Peštan PE SPIRAL SPIROPIPE pipes are resistant to salty water, alcohol, acids, alkalines, sulfates, aggressive gases and all kinds of detergents. On the other hand, can not be used for the transport of water which contains high percentage of benzene, benzine (petrol) or acetone.

- Temperature resistance of materials

PE SPIRAL SPIROPIPE pipes are resistant to temperatures up to 60 degrees short-term and 40° long-term.

Polypropylene has high temperature resistance, therefore the pipes made of this material also have heightened temperature load resistance. PP SPIRAL SPIROPIPE pipes are resistant to temperatures up to 95° short-term and 60° long-term.

## PROGRAM

- Production program Pešťan PE SPIRAL pipes SPIROPIPE for large sewer systems or non-critical transport of water includes pipes made of the highest quality polyethylene PE 100 with profiled ones with reinforcement in the ribs, in diameters of Ø300 up to Ø3000.

Nominal and inner pipe diameter

DN (mm)	DN/ID (mm)
300	300
400	400
500	500
600	600
700	700

DN (mm)	DN/ID (mm)
800	800
900	900
1000	1000
1100	1100
1200	1200

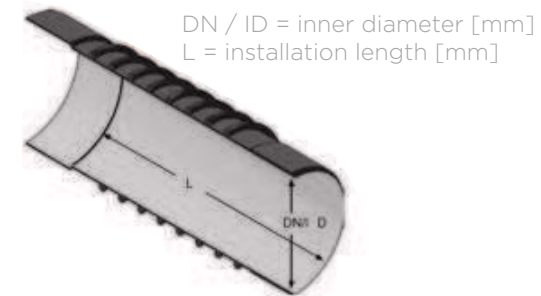

Also, these pipes are produced in standard length of 6 m. They can also be produced in other lengths according to project specification.

- Pešťan SPIRAL pipes SPIROPIPE are produced in more variants of strength (resistance) to the external load (depending on the step of the profiled outer layer of reinforcement, as well as on diameter):

**SN 2 KN/m<sup>2</sup>      SN 8 KN/m<sup>2</sup>      SN 16 KN/m<sup>2</sup>**

**SN 4 KN/m<sup>2</sup>      SN 12.5 KN/m<sup>2</sup>**

## TECHICAL

- Application and installation

Inner diameter and hydraulic characteristics of Peštan SPIRAL SPIROPIPE pipes remain the same over the time, regardless of the type of profile, thanks to the strong reduced roughness and low adhesion of the inner pipe walls. The nominal diameter corresponds to the effective inner diameter of the pipe, with tolerances allowed according to reference standards.

- Connection of the PE SPIRAL pipes

- Peštan PE SPIRAL pipes SPIROPIPE connected in two ways. The smaller diameters are connected over the header into which the EPDM rubber is mounted.



This type of compound is most widespread due to its own simplicity and speed of performance. At the female's end of pipe, the rubber was inserted during the production and it is homogeneously coupled with a muff. The male and female parts of the compound are performed in accordance with the parameters by the EN standard 13476.

The rubber is made in accordance with EN 681-1.

The larger diameters are connected either with the rubber band or electrofusion welding.

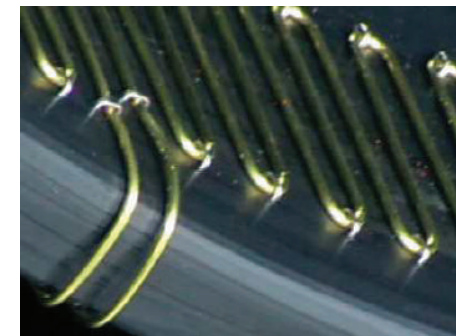
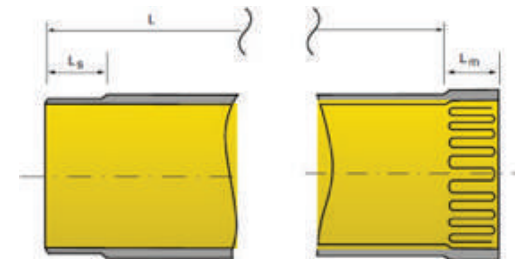
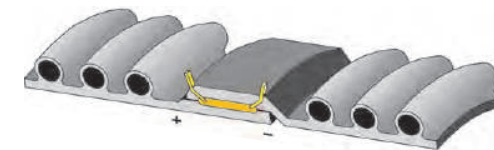

## TECHICAL

Peštan PE SPIRAL SPIROPIPE pipes are produced with extended socket into which it is possible to insert two electrodes for electrofusion welding that provides additional security and an increase of system resistance to internal pressure (up to 3 bar).

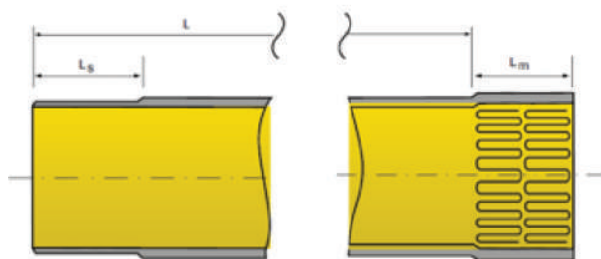

CONNECTION OF THE PE SPIROPIPE (DN)	
MUF AND RUBBER	ELECTROFUSION
300	300
400	400
500	500
600	600
700	700
800	800
900	900
1000	1000
1100	1100
1200	1200

CONNECTION OF THE PE SPIROPIPE (DN)	
MUF AND RUBBER	ELECTROFUSION
	1400
	1600
	1800
	2000
	2500
	3000



## TECHICAL

- Peštan PP SPIRAL pipes SPIROPIPE are connected over the header into which the EPDM rubber is mouthed.

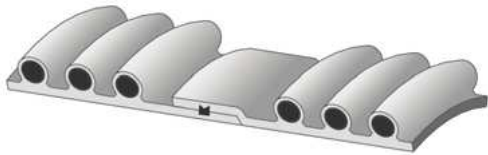

This type of connection is most widespread due to its own simplicity and speed of performance. At the female's end of pipe, the rubber was inserted during the production and it is homogeneously coupled with a muff. The male and female parts of the connection are performed in accordance with the parameters by the EN standard 13476.

The rubber is made in accordance with EN 681-1.

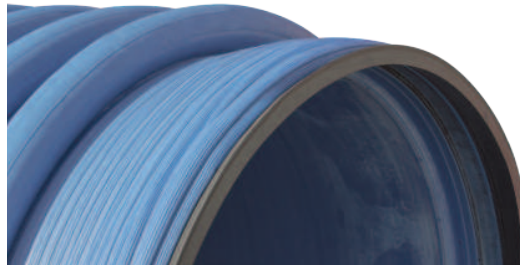

CONNECTION OF THE PP SPIROPIPE (DN)	
MUF AND RUBBER	ELECTROFUSION
300	
400	
500	
600	
700	
800	
900	
1000	
1100	
1200	

### Standards that correspond with PE and PP SPIRAL SPIROPIPE pipe system

PE and PP SPIRAL SPIROPIPE pipe system is produced and corresponds the requirements of the standard SRPS EN 13476-3: 2008 "Plastics piping systems mass for underground drainage and sewage without pressure - Piping systems with stainless steel polyvinyl chloride (U-PVC), polypropylene (PP) and polyethylene (PE) - Part 3: Specifications of pipes and fittings with smooth inner and molded outer surface and system, type B" and DIN 16961.

It is applicable with existing standards and regulations for the design of sewerage systems: "SRPS EN 752:2008 - Drain and sewer systems outside buildings", and also with the standard for the installation of pipelines SRPS EN 1610: 2006 Design and testing of lines and channels for wastewater.

## TECHICAL

---

- Types of profiles

Peštan currently offers three basic pipe profile products to its customers:

1. Peštan Spiro PR
2. Peštan Spiro CPR
3. Peštan Spiro OP

Depending on the needs of the project and the desired stiffness, these three profiles can be further modified by adding more levels of reinforcement and modification of diameter of the tube. The goal is to complete the optimization of the pipes for the project needs, with full quality guarantee.

- PR profile

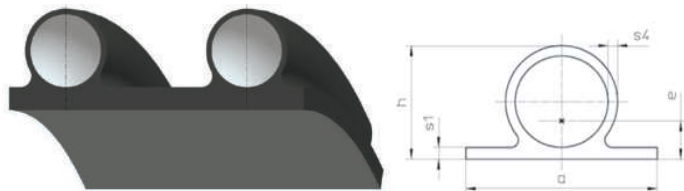

- CPR profile

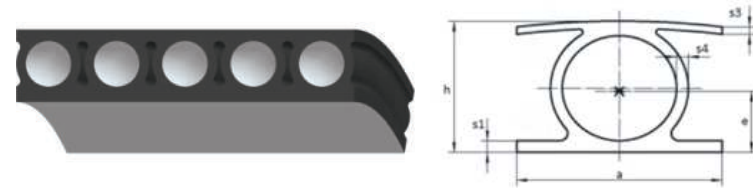

- OP profile



## ADVANTAGES OF PEŠTAN PE SPIRAL SPIROPIPE PIPES

---

- Durability

Reduced investment costs and work life expectancy for at least 50 years reduce costs of use.

- Saving time

Significant time saving can be achieved in pipeline placement due to the length and the low mass of the pipe, as well as due to easy and quick way of mounting and joining.

- Maintenance

Inner smooth sides of the walls, compactness and increased electrical, chemical and biological resistance, significantly reduce the costs of cleaning and maintenance.

- Hydraulics

Due to the improved hydraulic properties, they can be used in smaller diameters than in traditional pipes.

- Waterproof

100% leakproofness of joints: removal of penetration or leakage of fluid, and the penetration of roots due to welded joints.

- Lengths

Standard pipe length of 6m, as well as possibility of production of pipes in lengths according to the specification, significantly reduce the amount of connections.

- Usage

Possibilities of using Peštan SPIRAL SPIROPIPE tubes are numerous. Main application is found in the construction of underground sewers network, but excellent characteristics of this tube materials make it possible to create various systems where fast and easy assembly is required, chemical resistance, as well as the safety of the compounds.

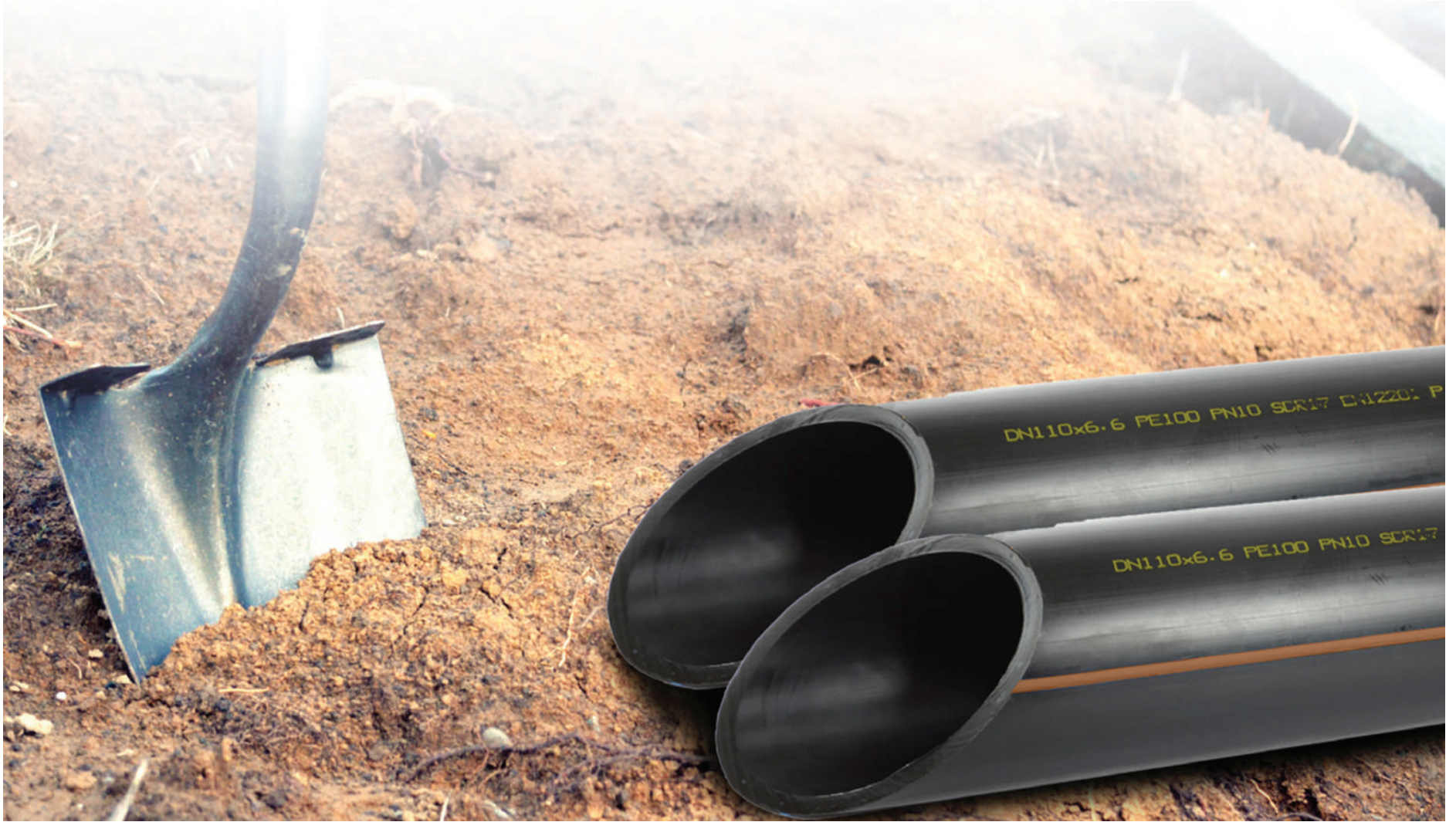

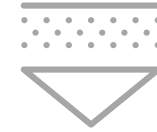

# HDPE PIPES FOR SEWAGE

Pipes for pressure sewerage systems made from high-density polyethylene

Pipes for pressure sewerage systems are produced in "PEŠTAN" exclusively from the original high-density PE, PE80 and PE100. MRS classification = 8Mpa or MRS = 10MPa means that the pipes after 50 years can handle the the same strain.

"PEŠTAN" uses the best raw materials from renowned manufacturers. The quality of our products "PEŠTAN" maintains with the quality department, in its modern laboratories. The materials have proof of independent European laboratory for MRS classification.

## Benefits of pipes PE80 and PE100

- The material is absolutely non-toxic and completely inert in contact with wastewater.
- Easy for transport and handling.
- Easy to connect by welding or joints.
- The transition from PE-80 to PE-100 should be performed by electro-socket
- The lifespan is more than 50 years.
- On the inner walls of the pipes, layers of stones nor deposits of dirt can be stuck, and consequently there is no reduction in flow during long-term use.
- Very flexible and extremely resistant to vibrations, seismic shocks and the movement of soil.
- Greater flexibility with pipes of PE-80.
- Due to the elasticity of the pipeline route can follow the configuration of the terrain, so there is no need for many fittings.
- The bending radius is 20d.
- Pipes are resistant to UV rays and to temperatures of -30 °C to + 60 °C.
- They have a high resistance to abrasion.
- Very low pressure losses because the friction coefficient 10 times less than that of steel pipes.

D (MM)	SDR 6 (S-2,5) PN32		SDR 7,4 (S-3,2) PN25		SDR 9 (S-4) PN20		SDR 11 (S-5) PN16		SDR 13,6 (S-6,3) PN12,5		SDR 17 (S-8) PN10		SDR 21 (S-10) PN8		SDR 26 (S-12,5) PN6		SDR 33 (S-16) PN5		SDR 41 (S-20) PN4	
	e <sub>min</sub>	KG/M	e <sub>min</sub>	KG/M	e <sub>min</sub>	KG/M	e <sub>min</sub>	KG/M	e <sub>min</sub>	KG/M	e <sub>min</sub>	KG/M	e <sub>min</sub>	KG/M	e <sub>min</sub>	KG/M	e <sub>min</sub>	KG/M	e <sub>min</sub>	KG/M
16	3,0	0,15	2,3	0,1	2	0,09														
20	3,4	0,18	3,0	0,154	2,3	0,13	2,	0,12												
25	4,2	0,278	3,5	0,240	3	0,21	2,3	0,17	2,0	0,151	1,9	0,14								
32	5,4	0,454	4,4	0,386	3,6	0,33	3	0,28	2,4	0,228	2	0,2								
40	6,7	0,701	5,5	0,600	4,5	0,51	3,7	0,43	3,0	0,354	2,4	0,29	2,0	0,251						
50	8,3	1,09	6,9	0,936	5,6	0,79	4,6	0,67	3,7	0,550	3	0,45	2,4	0,372	2,0	0,317				
63	10,5	1,73	8,6	1,47	7,1	1,26	5,8	1,06	4,7	0,869	3,8	0,72	3,0	0,586	2,5	0,482				
75	12,5	2,44	10,3	2,09	8,4	1,78	6,8	1,47	5,6	1,23	4,5	1,02	3,6	0,826	2,9	0,682				
90	15,0	3,51	12,3	3,0	10,1	2,56	8,2	2,14	6,7	1,76	5,4	1,46	4,3	1,19	3,5	0,987				
110	18,3	5,24	15,1	4,49	12,3	3,81	10	3,17	8,1	2,63	6,6	2,18	5,3	1,77	4,2	1,45				
125	20,8	6,75	17,1	5,77	14	4,3	11,4	4,11	9,2	3,39	7,4	2,78	6,0	2,28	4,8	1,86				
140	23,3	8,47	19,2	7,25	15,7	6,17	12,7	5,12	10,3	4,25	8,3	3,49	6,7	2,85	5,4	2,35				
160	26,6	11,0	21,9	9,44	17,9	8,04	14,6	6,73	11,8	5,54	9,5	4,55	7,7	3,73	6,2	3,08				
180	29,9	14,0	24,6	11,9	20,1	10,17	16,4	8,5	13,3	7,01	10,7	5,76	8,6	4,69	6,9	3,83				
200	33,2	17,2	27,4	14,8	22,4	12,58	18,2	10,49	14,7	8,65	11,9	7,11	9,6	5,81	7,7	4,74				
225	37,4	21,8	30,8	18,6	25,2	15,92	20,5	13,27	16,6	10,6	13,4	9,01	10,8	7,35	8,6	5,96				
250	41,5	27,0	34,2	23,0	27,9	19,57	22,7	16,33	18,4	13,5	14,8	11,05	11,9	9,03	9,6	7,38				
280	46,5	33,8	38,3	28,9	31,3	24,6	25,4	20,47	20,6	16,9	16,6	13,88	13,4	11,34	10,7	9,2				
315	52,3	42,7	43,1	36,5	35,2	31,11	28,6	25,9	23,2	21,4	18,7	17,57	15,0	14,3	12,1	11,7	9,7	9,7	7,7	7,60
355	59,0	54,3	48,5	46,3	39,7	39,5	32,2	32,88	26,1	27,2	21,1	22,36	16,9	18,2	13,6	14,8	10,9	12,1	8,7	9,6
400			54,7	58,8	44,7	50,12	36,3	41,75	29,4	35,2	23,7	28,27	19,1	23,6	15,3	19,1	12,3	15,7	9,8	12,5
450			61,5	74,4	50,3	62,7	40,9	52,87	33,1	44,6	26,7	35,81	21,5	29,8	17,2	24,2	13,8	19,9	11,0	15,8
500			68,3	92,0	55,8	77,3	45,4	65,24	36,8	55,0	29,7	44,25	23,9	36,9	19,1	29,9	15,3	24,4	12,3	19,4
560					62,5	97	50,8	80,8	41,2	69,0	33,2	55,43	26,7	46,2	21,4	37,5	17,2	30,7	13,7	24,4
630					71	127,6	57,2	102	46,3	87,3	37,4	70,21	30,0	52,9	24,1	47,4	19,3	38,7	15,4	30,8
710					80*	162*	64,5	130	52,2	110,8	42,1	89	33,9	74,2	27,2	60,2	21,8	49,2	17,4	39,0
800					90,1*	205,7*	72,7	170,4	58,8	140,7	47,4	113	38,1	94,0	30,6	76,3	24,5	62,4	19,6	49,5
900							81,7	211,8	66,1	174,9	53,3	143,4	42,9	116,8	34,4	95,1	27,6	76,7	22	61,5
1000							90,8	261,6	73,4	215,9	59,3	177,2	47,7	144,4	38,2	116,9	30,6	94,0	24,5	76,2
1200									88,2	311,1	71,1	254,9	57,2	207,8	45,9	168,4	36,7	135,9	29,4	109,6

\*other sizes are available upon request

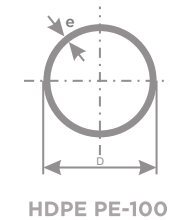
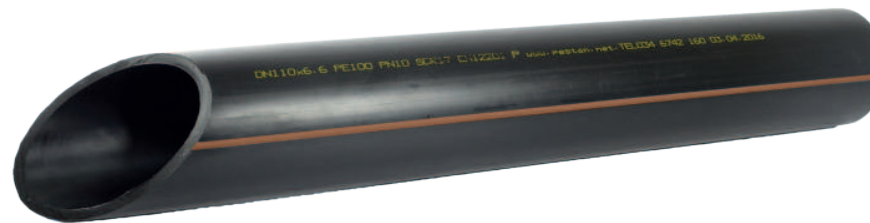

D (MM)	SDR 6 (S-2,5) PN 25		SDR 7,4 (S-3,2) PN 20		SDR 9 (S-4) PN 16		SDR 11 (S-5) PN 12,5		SDR 13,6 (S-6,3) PN 10		SDR 17 (S-8) PN 8		SDR 21 (S-10) PN 6		SDR 26 (S-12,5) PN 5		SDR 33 (S-16) PN 4		SDR 41 (S-20) PN 3,2	
	e <sub>min</sub>	KG/M	e <sub>min</sub>	KG/M	e <sub>min</sub>	KG/M	e <sub>min</sub>	KG/M	e <sub>min</sub>	KG/M	e <sub>min</sub>	KG/M	e <sub>min</sub>	KG/M	e <sub>min</sub>	KG/M	e <sub>min</sub>	KG/M	e <sub>min</sub>	KG/M
16	3,0	0,15	2,3	0,1	2,0	0,09	1,9	0,9	1,8	0,08										
20	3,4	0,18	3,0	0,16	2,3	0,13	2,0	0,12	1,9	0,11										
25	4,2	0,278	3,5	0,24	3,0	0,21	2,3	0,17	2,0	0,15										
32	5,4	0,454	4,4	0,38	3,6	0,32	3,0	0,28	2,4	0,23	2,0	0,2								
40	6,7	0,701	5,5	0,6	4,5	0,56	3,7	0,43	3,0	0,36	2,4	0,29	2,0	0,24						
50	8,3	1,09	6,9	0,93	5,6	0,78	4,6	0,67	3,7	0,54	3,0	0,45	2,4	0,37	2,0	0,317				
63	10,5	1,73	8,6	1,47	7,1	1,25	5,8	1,06	4,7	0,87	3,8	0,72	3,0	0,58	2,5	0,482				
75	12,5	2,44	10,3	2,09	8,4	1,76	6,8	1,47	5,6	1,23	4,5	1,02	3,6	0,82	2,9	0,682				
90	15,0	3,51	12,3	2,99	10,1	2,54	8,2	2,14	6,7	1,76	5,4	1,46	4,3	1,18	3,5	0,987				
110	18,3	5,24	15,1	4,48	12,3	3,77	10,0	3,17	8,1	2,61	6,6	2,18	5,3	1,77	4,2	1,45				
125	20,8	6,75	17,1	5,77	14	4,86	11,4	4,11	9,2	3,36	7,4	2,78	6,0	2,27	4,8	1,86				
140	23,3	8,47	19,2	7,25	15,7	6,11	12,7	5,12	10,3	4,21	8,3	3,49	6,7	2,83	5,4	2,35				
160	26,6	11,0	21,9	9,44	17,9	7,95	14,6	6,73	11,8	5,29	9,5	4,55	7,7	3,72	6,2	3,08				
180	29,9	14,0	24,6	11,9	20,1	10,1	16,4	8,5	13,3	6,74	10,7	5,76	8,6	4,67	6,9	3,83				
200	33,2	17,2	27,4	14,8	22,4	12,4	18,2	10,49	14,7	8,3	11,9	7,11	9,6	5,78	7,7	4,74				
225	37,4	21,8	30,8	18,7	25,2	15,6	20,5	13,27	16,6	10,6	13,4	9,01	10,8	7,30	8,6	5,96				
250	41,5	27,0	34,2	2,3	27,9	19,4	22,7	16,33	18,4	13,4	14,8	11,05	11,9	8,93	9,6	7,38				
280	46,5	33,8	38,3	28,9	31,3	25	25,4	20,47	20,6	16,7	16,6	13,88	13,4	11,3	10,7	9,2				
315	52,3	42,7	43,1	36,6	35,2	30,8	28,6	25,9	23,2	21,2	18,7	17,57	15,0	14,2	12,1	9,7	9,7	7,7	7,60	
355	59,0	54,3	48,5	46,3	39,7	39,1	32,2	32,88	26,1	26,9	21,1	22,36	16,9	18,0	13,6	14,8	10,9	12,1	8,7	9,6
400					44,7	49,6	36,3	41,75	29,4	34,1	23,7	28,27	19,1	22,9	15,3	19,1	12,3	15,7	9,8	12,5
450							40,9	52,87	33,1	43,2	26,7	35,81	21,5	28,9	17,2	24,2	13,8	19,9	11,0	15,8
500							45,4	65,24	36,8	53,4	29,7	44,25	23,9	35,7	19,1	29,9	15,3	24,4	12,3	19,4
560							50,8	80,8	41,2	66,9	33,2	55,43	26,7	44,7	21,4	37,5	17,2	30,7	13,7	24,4
630							57,2	102	46,3	84,6	37,4	70,21	30,0	56,4	24,1	47,4	19,3	38,7	15,4	30,8
710							64,5	130	52,2	109	42,1	89	33,9	71,8	27,2	60,2	21,8	49,2	17,4	39,0
800							72,7	170,4	58,8	138	47,4	113	38,1	91,8	30,6	76,3	24,5	62,4	19,6	49,5

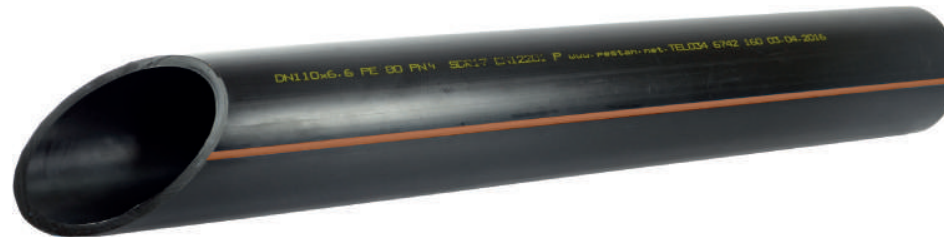
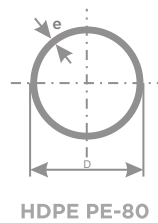





# MANHOLES

---

BELOW GROUND



# DRAIN MANHOLES Ø315 AND Ø400

Manholes with gutter on bottom are being manufactured from polypropylene (manhole bottom). Manhole body as well as telescopic extension are made from PVC or PP strong pipe, being connected with rubber seal for telescopic connection which enables absolute waterproofing.

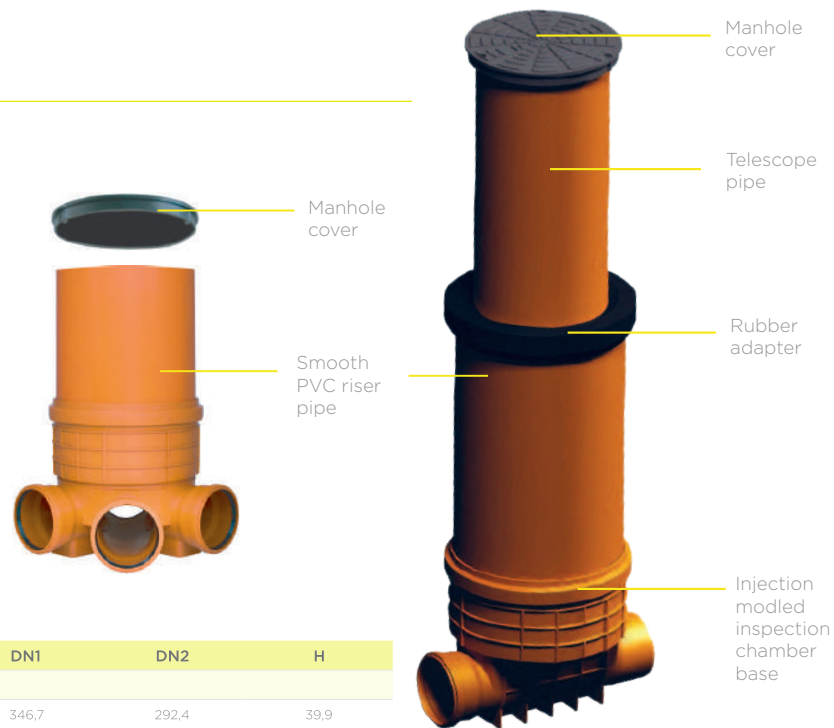

NAME	PICTURE	CODE	DN	DN1	DN2	H
<b>DRAIN MANHOLES LINEAR TRAY</b>						
		10204560	315	346,7	292,4	39,9
		10204561	400	413	370	49

NAME	PICTURE	CODE	(D/D1)	H	H1	H2	L
<b>DRAIN MANHOLES</b>							
		10799298	315/110	330	295	140	435
		10799224	315/160	384	281	190	479
		10799230	400/110	360	289	226	562
		10799220	400/160	420	315	207	554
		10799221	400/200	470	340	207	586

<b>DRAIN MANHOLES</b>							
		10799229	315/110	356	278	201	444
		10799225	315/160	395	309	185	490
		10799231	400/110	401	306	226	534
		10799222	400/160	420	319	207	559
		10799223	400/200	470	344	207	584

## EXTENSION WITH PVC OR PP SMOOTH PIPE

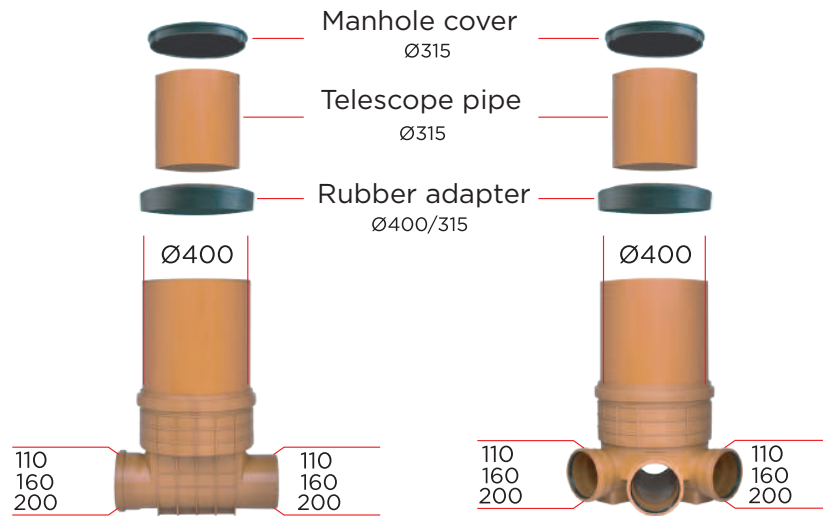
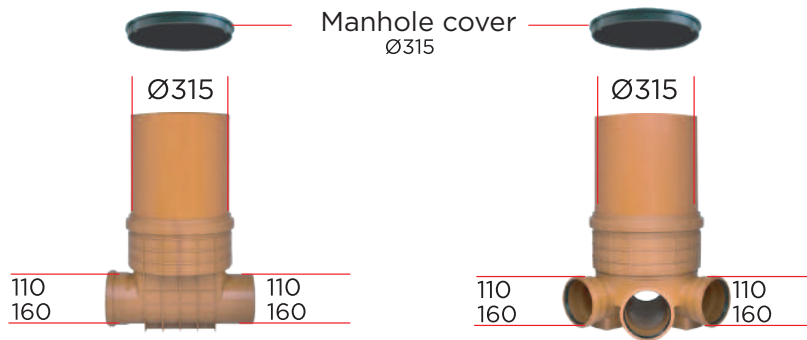

## EXTENSION WITH PP CORRUGATED PIPE

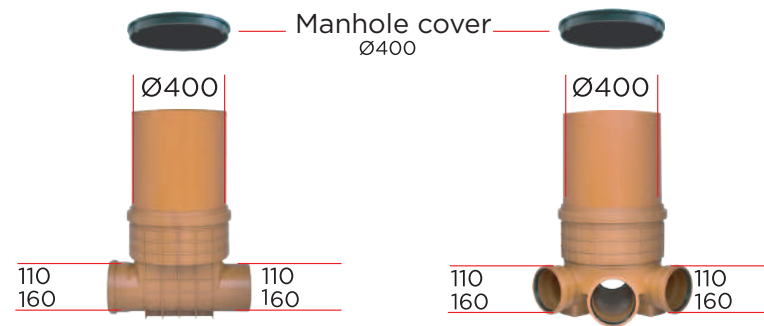
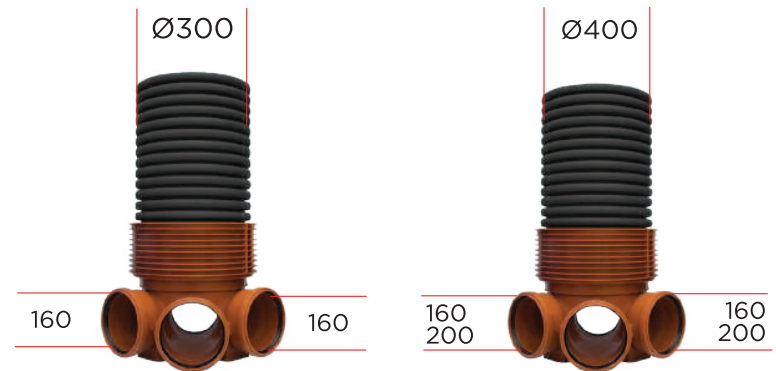

# DRAIN MANHOLE Ø630

## PRODUCT AVAILABILITY / OPTIONS

Available two types :  
**Straight through manhole**  
**Collective manhole**

Drain manhole bottom available for connection on pipelines with DN 315 and DN 200. In cases where connections to other diameters are required, reduction fittings from Pestan standard portfolio may be used. If required, there is possibility of connecting drain manhole with pipeline that is projected for corrugated pipes. For this purpose any of transition items from Pestan portfolio may be used.

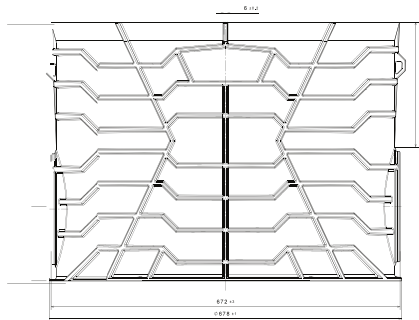

Technical drawing of straight through drain manhole 630/200

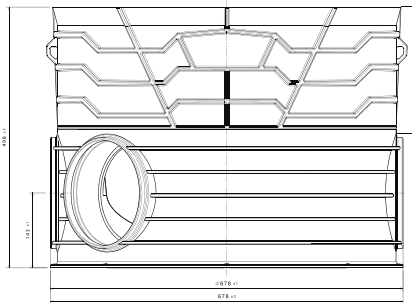

Technical drawing of straight through drain manhole 630/200

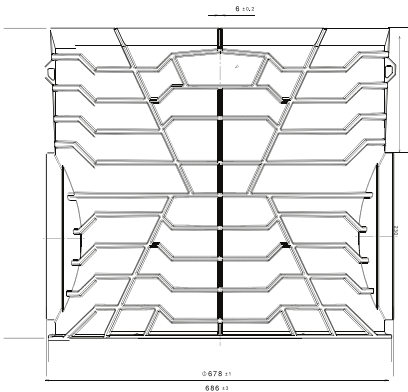

Technical drawing of straight through drain manhole 630/315

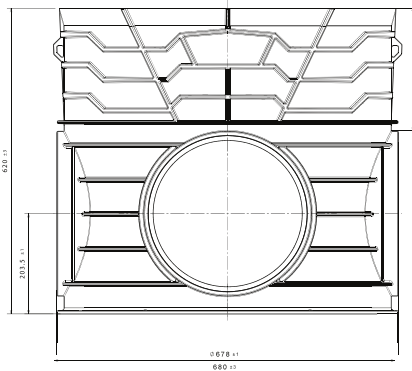

Technical drawing of straight through drain manhole 630/315

**Straight through drain manhole**  
 Ø630/Ø315



**Straight through drain manhole**  
 Ø630/Ø200



**Collective drain manhole**  
 Ø630/Ø315



**Collective drain manhole**  
 Ø630/Ø200



## DRAIN MANHOLE Ø630

Beside visual effect, reinforcement ribs are designed to provide better strength. Hooks for hanging / descending manhole to the hole / channel are designed to provide reliability as being reinforced from upper side where cord or rope should hang, so these hooks without problems can resist manhole weight while descending.







Top point of the manhole bottom is adjusted for corrugated pipe DN 630 OD to which is being connected by rubber seals. Grip, on certain models where technically was possible to be designed, serves for better support, in case maintenance repairman is going down to the manhole, Grip prevents from shoes slipping.

On the bottom of each manhole there is possibility of placing stopple, exclusively on client's demand. Ribs on lower side of drain manhole serve as structural reinforcement from soil from all directions, as well as reinforcement for repairmen in charge for pipeline maintenance who will descend to the manhole.

## PURPOSE

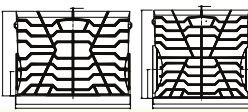
Pestan darain manhole is intended to be used for collecting all kind of waste water in storm water systems as well as junction for house connections. It is possible to use drain manhole as revision manhole also, which is very important when constructing house connections and connecting multiple objects before connecting to main pipeline.

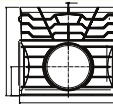

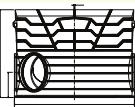
NAME	PICTURE	CODE	(D1/D2)	H	H1	L
<b>STRAIGHT THROUGH DRAIN MANHOLE</b>						
						
						
		10799233	630/200	498	355	678
		10799234	630/315	620	416	686
<b>COLLECTIVE DRAIN MANHOLE</b>						
						
						
		10799235	630/200	498	355	678
		10799236	630/315	620	416	680
<b>COLLECTIVE DRAIN MANHOLE</b>						
						
						
		10799235	630/200	498	355	678

## DRAIN MANHOLE CONNECTION TO DIFFERENT TYPES OF PIPELINES



Connection directly with smooth pipe.



Connection by reducer.



Connection with corrugated pipe.

Relief ring for manholes DN 630 enables their assembly in areas with bigger static load.



(relief ring for manholes DN 630)

**Extension**  
Ø600 ID



**EXTRUSION CONNECTION**

**Relief ring**



**Extension**  
Ø630 OD



**RUBBER BAND CONNECTION**

Manhole is available in diameters Ø630/315 and Ø630/200. If it needs to be connected to other diameters of the pipeline, reduction pieces can be used Pešťan's standard production assortment.

REDUCED PIECES FOR SMOOTH PIPES

Ø315/Ø250	Ø200/Ø160	Ø200/Ø125	Ø200/Ø110
-----------	-----------	-----------	-----------

If necessary it is possible connecting the drain manhole with the pipeline that is designed of corrugated pipes. For this need it is possible to use some of the transient pieces from the Pešťan production assortment.

TRANSITIONAL PIECES FROM SMOOTH TO CORRUGATED PIPE

Ø300/Ø315	Ø250/Ø250	Ø200/Ø200	Ø140/Ø160
-----------	-----------	-----------	-----------

# IMPRUVA INJECTION MOLDED DRAIN MANHOLE Ø1000

In order to meet all trends of modern construction Pestan company, beside existing one, has expanded it's product portfolio with new product - polypropylene injected drain manhole with DN 1000. Application of these manholes is in all kinds of systems for collection of waste and storm water. Pestan manholes are manufactured by injection molding process from polypropylene of the highest quality as per European Norm for manhole manufacturing - EN 13598. By combining manhole elements together with other Pestan products we are able to meet and fulfill any project request, whether it is about non leveled, or pipeline made of smooth or corrugated pipes.

## ELEMENTS

Drain manhole consists of few elements, which assembled together makes an integral product. Items that manhole consists of are: base, bottom plug, extension with climbing frames, cone.

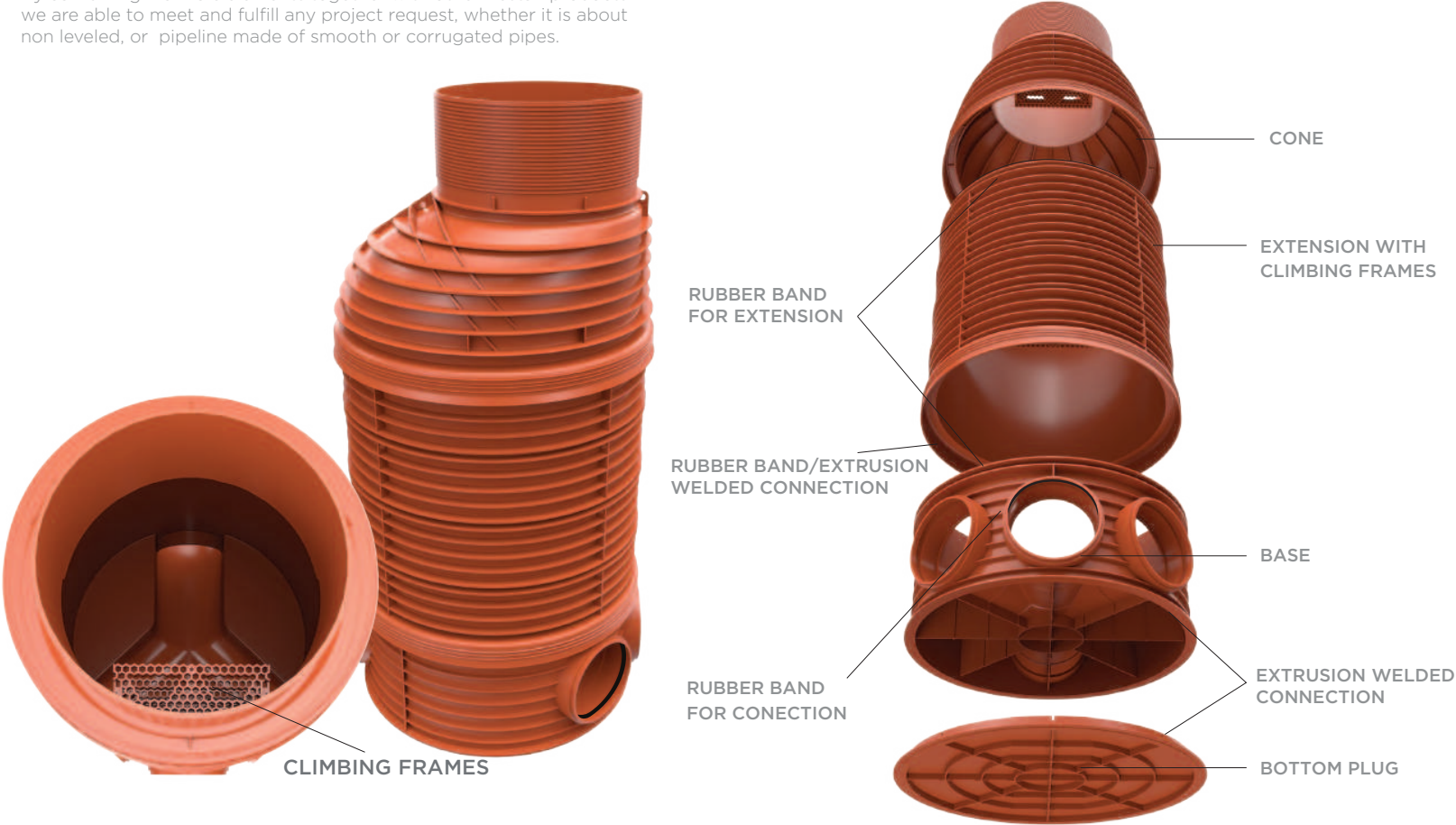

## MANHOLE BASES

Manhole bases as monolithic forms are injected with already formed gutter and preinstalled rubber seal with highest quality of EPDM which guarantees waterproofing of the connection of manhole base and extension or cone. In each connection on manhole is installed EPDM rubber as well.

In standard offer are bases with inlets DN 250 and 300 and outlets DN 250 and 300 under different angles for Pestan PVC smooth or corrugated pipes. Transition to Pestan corrugated ID pipes is possible with Pestan transition item from smooth to corrugated pipes. As per project demand, connections of bigger diameters intended for pipelines made of smooth or corrugated pipes DN 400, 500 600 and 630 is also possible.

Bottom plug is injected element from polypropylene intended to be positioned below the base when necessary to have closed or doubled bottom. Assembly is optional.

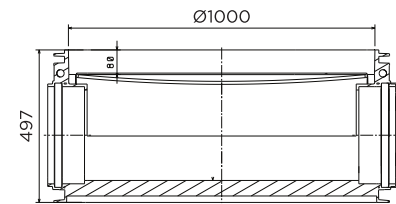

Inlet/outlet DN315

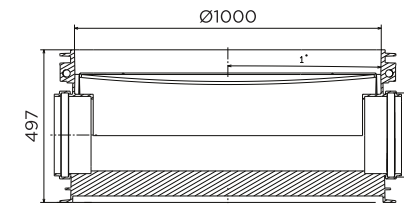

Inlet/outlet DN250

BASE	DN250	DN315	Number of inlets	Inlet angle
	✓	✓	1	180°
	✓	✓	3	135° 180° 225°
	✓	✓	2	225°
	✓	✓	2	135°



## EXTENSIONS

Extension with climbing steps is injected molding part of the manhole with different optional height; by adding these parts to the base appropriate manhole height is achieved.

Pestan produces extensions in heights 250, 500, 750, 1000mm and enables adjusting manhole height to each project. In extensions themselves are preinstalled climbing steps on 250mm height from each other, by this easier entering and manhole leaving is achieved while intervention. Climbing steps are made of polypropylene by injection molding method as per EN 14396 and EN 13101.

## Cone

Cone ending is injecting molded element which, by its adding on the manhole base and connection - makes manhole itself as complete product. Ending cone element are parts for closing which decrease upper manhole diameter enabling assembly of different types of covers.

Beside advantage of manhole height adjustment Pestan manhole are known for their lightness which makes manipulation on the spot easier, as well as simple way of connection to pipeline. Material used for manufacturing guarantees consistency and extraordinary chemical resistance.

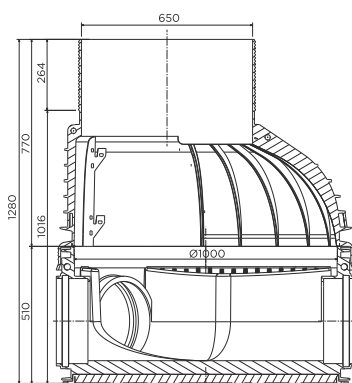

minimum height manhole

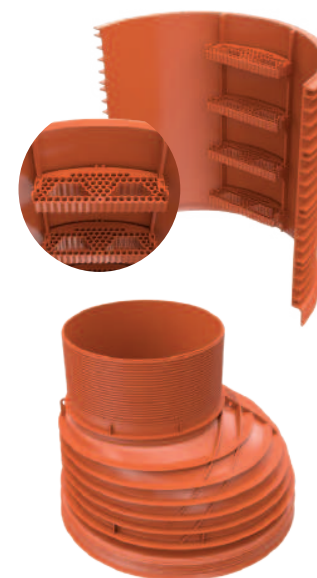
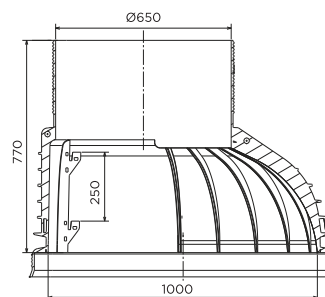
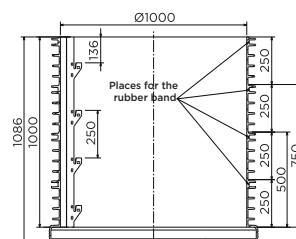

## MANHOLE HEIGHT

Pestan injected manholes are with adjustable height and in this way can meet any project demand. Minimal manhole height in combination of manhole base and cone that is cut to the minimum is 1016 mm for manholes with connectors DN 250 and 315. Maximal manhole height is limited to 6 m and is achieved by adding extensions.

## CONNECTING

Element connecting is performed by pre-installed seals made of highest quality EPDM rubber for waterproofing guarantee. Except this, connection by extrusion welding of elements to each other is also possible and in this way unbeakable connection is made.

## ADDITIONAL CONNECTORS

If required and predicted by project there is possibility for connection of non leveled pipelines by combination of cutting manhole body together with injecting welding of connector itself for manhole body.

## DRAIN MANHOLES

Peštan company has included DRAIN MANHOLES in its product range.

- Drain manholes Ø400 ID
- Drain (revision) manholes Ø500 ID
- Drain (revision) manholes Ø600 ID

\*ID - Inner diameter

## PURPOSE

These products are mainly designed to collect rainwater in the rainwater sewage systems for individual home installations and also in systems of civil engineering (collecting rain water from and near the roads, etc) In addition it is possible to use drain manholes Ø600 (sometimes Ø500

too) as revision as well which is particularly important during installation of home sewer and connection of multiple objects before joining the main line etc. With this, relevant joining standards are met, with additional reductions in joining costs

and installation time, while corrections of the mistakes on terrain (such as axel and angle issues as well as height of connecting lines) are facilitated by its flexibility.

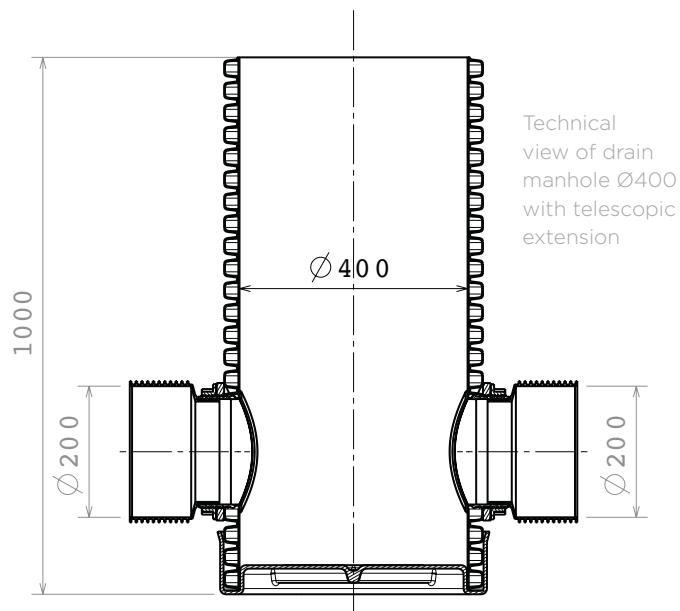

## MANHOLES WITH SLUDGE TRAP

**Peštan produces manholes with sludge trap as a integral part of the collector in gravity sewer systems, waste water systems, storm water or combined. These manholes are made of polypropylene.**

Manholes are made of monolithic structures composed of a flat bottom, manhole body (PP corrugated pipe) and connections as specified by projects. The elements of each manhole are welded to each other by extrusion welded.

Manholes are made by order or project specification.

### Dimensions

DN 800 mm

### Material

Polypropylene

### Standards

SRPS EN 13589

### Fields of application

Gravity sewer systems  
Waste water systems, storm water and combined  
Various industrial application.



## DESCRIPTION

Peštan produces manholes with sludge trap as a integral part of the collector in gravity sewer systems, waste water systems, storm water or combined.

They are used as revision manholes, cascading manholes, manholes with sludge trap or manholes for sewer flushing.

Manholes are made of monolithic structures composed of a flat bottom, manhole body (PP corrugated pipe) and connections as specified by projects.

The elements of each manhole are welded to each other by extrusion welded.

### Advantages

- Long durability
- Water tightness
- Resistance to aggressive chemicals
- Easy handling
- Quick installation
- Easy height adjustment

## CONSTRUCTION

**Construction of drain manholes is usually performed with the Sedimentation, and in this system the height of sedimentation can be modified and adapted to specific customer requirements. Manhole height can be easily adjusted on the ground and by reducing the vertical which is always PP double layer corrugated pipe SN 8 it can be fully adapted to the situation before setting of cover grids.**

### Construction consists of:

- Drain bottom
- PP corrugated pipe SN 8 vertical
- Appropriate number of SAG's used to form one output and one or more inputs.

Using SAG's enables the various versions of connecting smooth or corrugated pipe diameters in the 140 ID corr. 160 OD corr. 160 SW, and also

ID 200 corr. and 200 SW. It is possible to form the manhole on the spot, which is a huge advantage because the drilling and installation of SAG's can be performed at the site of installation with simultaneous correction of alignment errors and regular deviations from the projected documents. Due to the extremely high ring stiffness of used PP corr. pipes, recommended height of manhole can range up to 5 m.

The table below contains the basic data related to drain manholes:

	DRAIN MANHOLE 400 MM	DRAIN REVISION MANHOLE 500MM	DRAIN REVISION MANHOLE 600 MM
Minimal angle between the terminal	60	45	45
Maximal height of the manhole - h	5000	5000	5000
Minimal height to the port axis - h1	260	300	310
Maximal number of input ports	2	3	4

The seal between the vertical and manhole bottom is achieved by using common rubber ring which is used for PP corrugated pipes which allows sealing up to 0.5 bar and 5 m height of the water column which defined maximum height of the manhole.

Drain manhole is supplied as a telescopic too. In this version base is upgraded with coupling ring and PVC Ø315 OD.

This is a very popular and sought option for designers and contractors because this structure results in greater depth of installation with a

flexible coupling ring connection and in case of heavy loads due to increased surface pressure or increased construction depth, transmission of loads based on the manhole is prevented. Building the concrete ring around the PVC pipe is required.

## DELIVERY

At the request of the customer, manhole can be supplied in kit-form which is particularly popular with final customers because of lower prices and a relatively simple and rapid preparation of manholes users, which leaves them with possibility of corrections and changes.

These products can be delivered and fully assembled on the basis of data obtained from our customers. This can significantly speed up the delivery of the alignment setting but reduces the possibility of correcting possible deviations on terrain.





# CONCRETE MANHOLES

---

BELOW GROUND

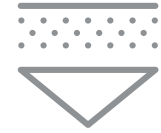

## CONCRETE MANHOLES

---

Pest concrete manhole is produced from the best quality concrete by high strength method vibro pressing and SCC method (Self Compacting Concrete). The concrete manhole is used for implementation of fecal and storm sewerage. They are used in infrastructural construction of industrial areas, but also in communal construction in settlements. All manholes are produced by project plans. Concrete manholes are according to requirements of project composed of different assembly elements, and different shape of the entrance and exit openings.

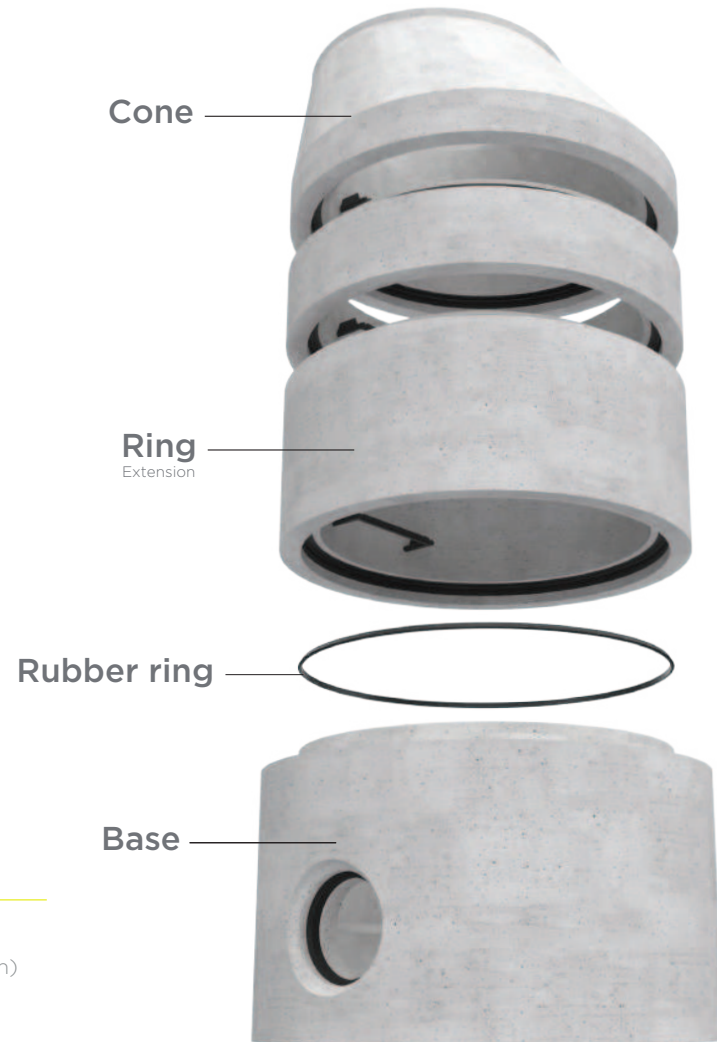

## ELEMENTS

---

The elements used to complete the manhole are the manhole base, the extension (extension) and the conical end.



## PRODUCTION PROCESS

---

By improving the technology and using a special smart solution for the individual shaping of the kinete and pipe connection during the production of concrete bases, it is possible to respond to the requirements of the most complex projects. Due to the individual approach in the production process of concrete bases, we can produce a configuration of connectors and kinets at the request of the investor or customer



Production of kinete models and connections to base are being done on CNC machines by production of negative body by cutting custom extruded polystyrene which enables the modeling of concrete bases. Slow and undesirable retention of waste water in the channel kinetes are avoided by constant drop in the entire course of the channel, including the connection of the pipe and the manhole kinet

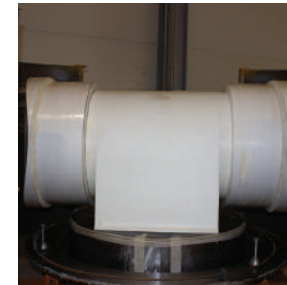

Production process of concrete manholes is completely aligned with EN 1917 - European standard for concrete manholes. They are produced by vibro-pressing of high quality concrete C30/37. Brand of concrete from which elements of manholes are produced is MB40.

- In production we use CEM1 52.5R without additives with latent hydraulic properties.
- We use economic separated aggregates without admixtures, stone filler.
- We use additives to improve the compactness of concrete.
- Aerant to increase resistance to the effects of atmospheric influences.
- Chemical additive to reduce water absorption.

After the steel formwork is filled and the concrete hardens, the concrete base the shaft is removed from the formwork and prepared for transport to the construction site. The most modern concrete technology contributes to a long life elements. Signs of aging and wear of elements are reduced to a minimum.

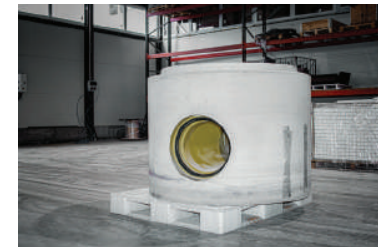

## TYPES OF BASES

---

We produce 3 main types of bases:

### 1. FLAT BOTTOM BASE WITH RUBBER RING **BETO**

---

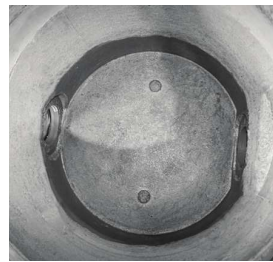

Wall thickness of the base is 150mm-230mm depending on the dimensions of input and output connector.

Height of the base 500mm-1000mm

We produce concrete manholes in dimension of 1000mm

### 2. KINET BOTTOM BASE AND RUBBER RING **BETO PLUS**

---



### 3. LINER BASE **BETO PRO**

---



For easier handling and manipulation on the construction site, we install in bases special handles for hanging and carrying the base



There are several types of kinete:

- **TRANSITORY**
- **COLLECTIVE**
- **KINETA ON REQUEST IN ACCORDANCE WITH TECHNICAL POSSIBILITIES**

Pass-through bases are made in vibro-pressed concrete technology for connections up to Ø250. Collector bases and Pass-through bases with connections from Ø315 to Ø630 are made using the SCC method (casting method).

## TECHNICAL DATA

DESCRIPTION (DN 1000)	MM
Internal diameter of base	1000
Base height	500 - 1000
Wall thickness for connections up to DN 315	150
Wall thickness for connections up to DN 400	170
Wall thickness for connections up to DN 500	190
Wall thickness for connections up to DN 630	230
Dimension of pipe connections for smooth pipes	110 - 630
Dimensions of pipe connections for ribbed pipes	160 - 400
Wall thickness of extensions and tapered end	120
The height of the tapered end	600

## CONCRETE MANHOLE ELEMENTS

---

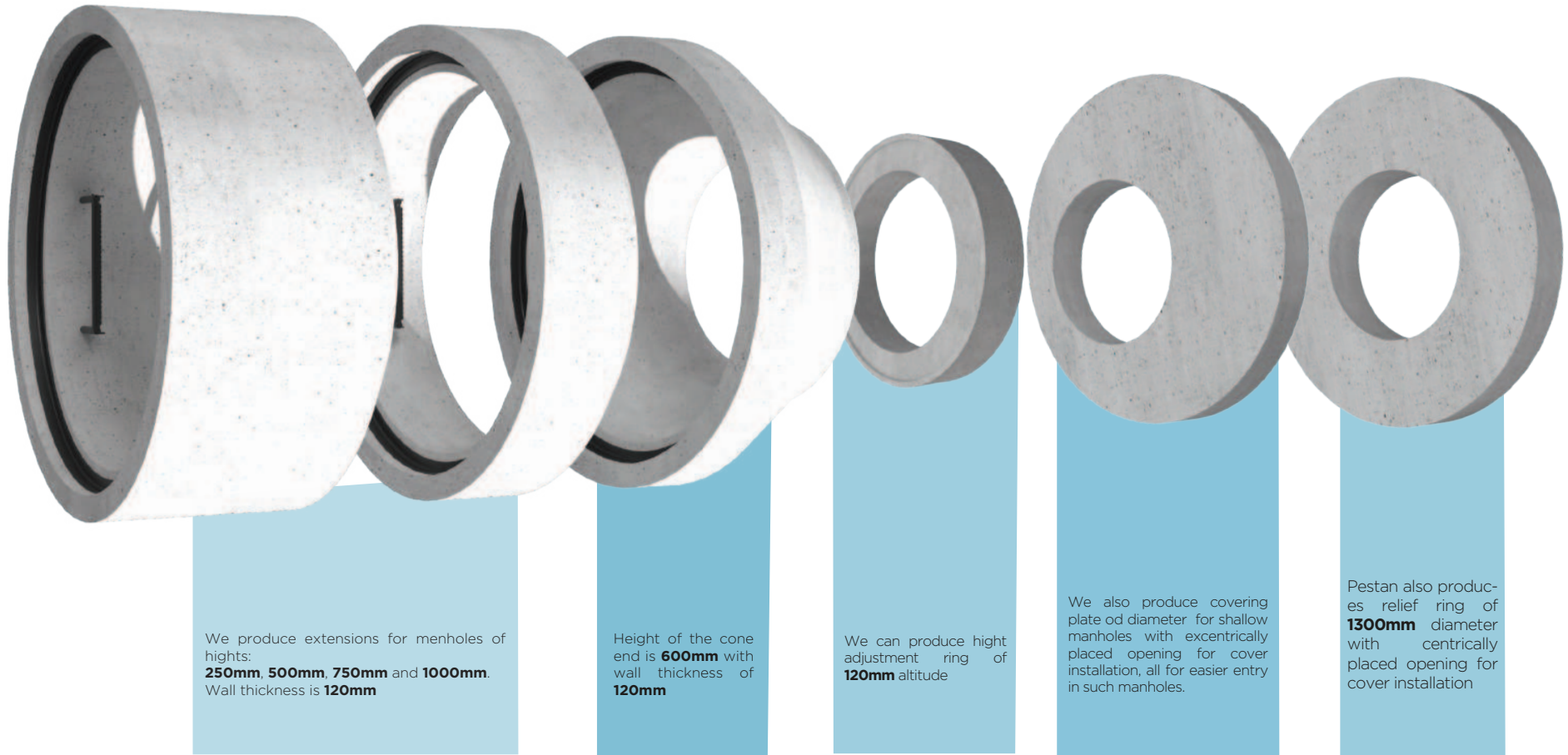

We produce extensions for manholes of heights: **250mm, 500mm, 750mm** and **1000mm**. Wall thickness is **120mm**

Height of the cone end is **600mm** with wall thickness of **120mm**

We can produce high adjustment ring of **120mm** altitude

We also produce covering plate of diameter for shallow manholes with excentrically placed opening for cover installation, all for easier entry in such manholes.

Pestan also produces relief ring of **1300mm** diameter with centrally placed opening for cover installation

# RUBBER SEALS



All concrete manholes are equipped with rubber seals and are watertight.

Sealing between concrete elements is achieved by subsequent mounting rubber bands on the upper part of the base or extensions.

Connection pieces can be used (transition pieces) for pipes with integrated rubber bands (corrugated-ribbed pipes).

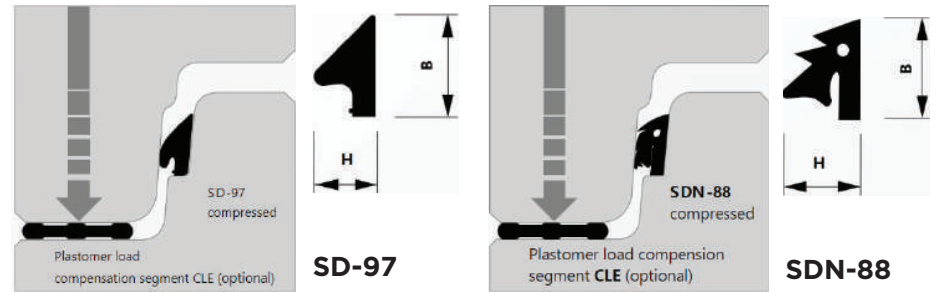

*subsequent mounting of rubber bands on the upper part of the base or extensions.*

All fittings are used with integrated rubber rings. These integrated seals are poured together with the kinet and thus form a solid connection. Such joints are used for joints with smooth pipes (PVC, PP STRONG, PEHD, ...)

Connection pieces (transition pieces) can be used for pipes with integrated rubber bands (corrugated-ribbed pipes).



Integrated rubber rings



Direct smooth pipe connection



Reducer connection



Corrugated pipe connection

## CLIMBING FRAMES

---

Climbing frames in manholes are made of solid steel, covered with non-slip material with a layer of polyethylene, completely and permanently protected from corrosion, as per EN 13101. Climbers are cast in the production process ensuring greater safety and less assembly time on the construction site.



## ELEMENTS OF REVISION WINDOW

---

**Base** of revision window with connectors for pipes with integrated rubber bends

**Extension** of revision window

**Height adjustment ring**

**Cone** - final element of the inspection window with an integrated seal for waterproofing

**Climbing frames** covered with non-slip material

**Rubber seals** for waterproofing

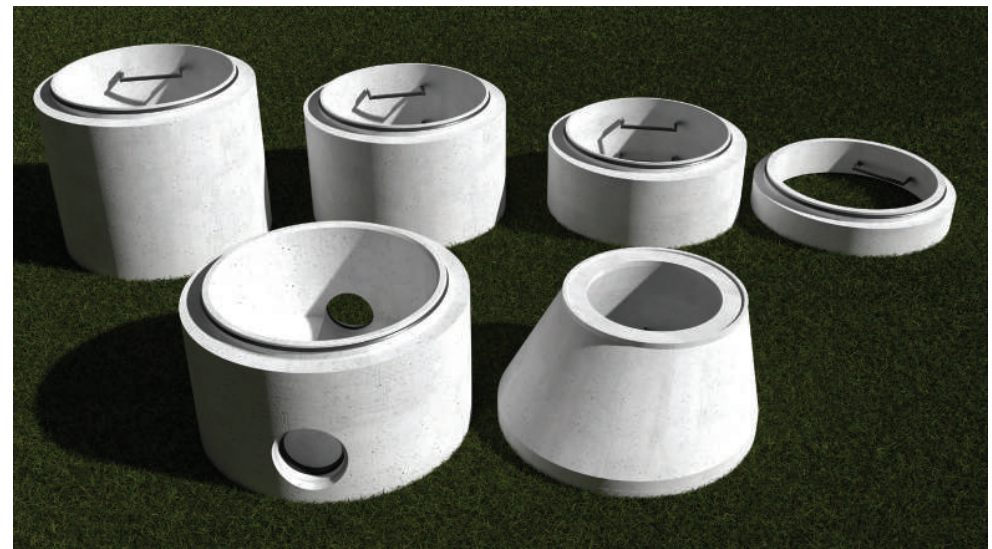

Particular attention must be paid to the mutual joining of elements if you want to make the joints waterproof.

All elements are connected exclusively and strictly vertically one on top of the other, during which it is necessary to keep a strict account so that it does not come to mutual bending of the elements.

In this way, it is achieved that the rubber which is subsequently mounted on the upper surface of the lower element, and before lowering the upper element, fill its own role completely and achieve a 100% of watertight joint.

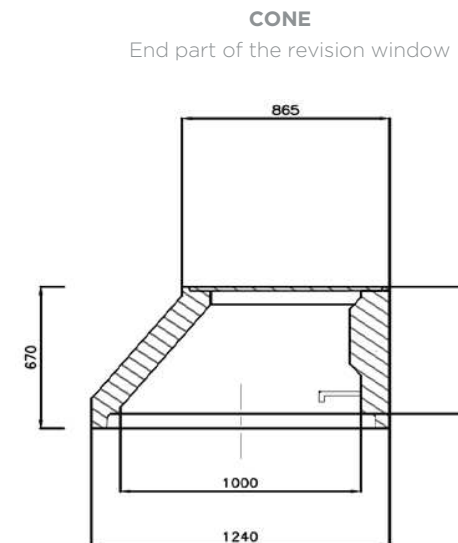
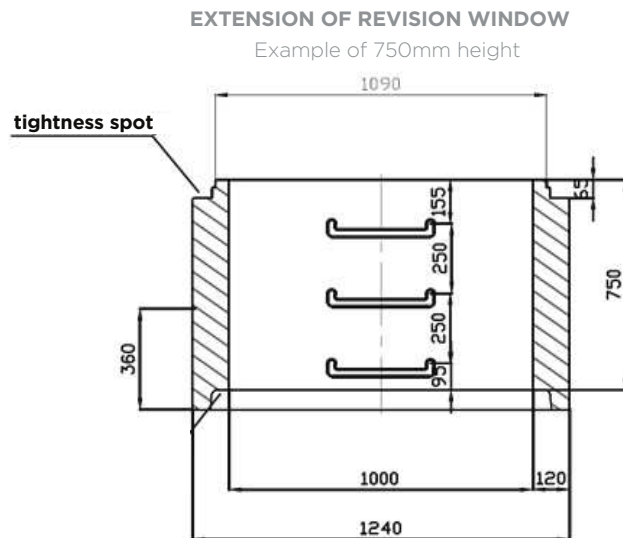
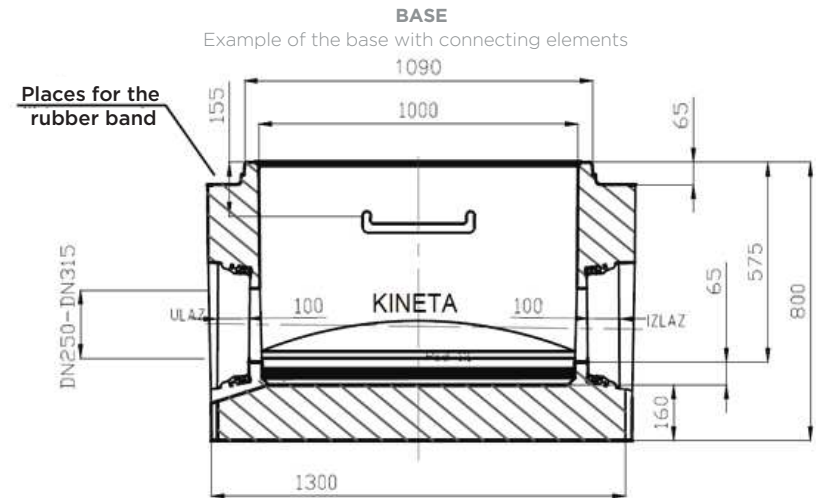

---

Assembly of elements of the inspection window:

The base of the inspection opening is placed on a concrete base or a base made of stone aggregate. Construction of the base, assembly and backfilling of pipes and shafts is prescribed according to standards EN 1610 and EN1917.

The quality of the substrate is the responsibility of the contractor and must be in accordance with the conditions prescribed in the project. The project defines: the width of the construction pit, the slope excavation slopes, stabilization of the substrate and the type of material used for it, backfilling of the construction pit, layer materials and degree of backfilling compaction.

Extensions and/or a conical element are placed on the base of the inspection window.

During the assembly of the elements of the shaft, the contractor is obliged to use the appropriate equipment in order to avoid possible damage to the elements and enable the appropriate the quality of the fit in the elements, taking into account the integrated rubber seals.

All elements must be cleaned of dirt with special attention in the part where the sealing rubber is located, both between the elements of the shaft and in the place where connect the pipes.

## TRANSPORT

---

The following recommendations should be followed during transport and manipulation:

- Transport the elements according to their dimensions and weight.
- It is recommended to lay the elements on wooden pallets to reduce the risk of damage.
- When laying the elements in the construction pit, use adequate tools and machines for transferring and positioning the elements.
- Use the highest precautions at all times to avoid injury to workers.



—



—







# DRAINAGE



# HDPE OD DRAINAGE PIPES



HDPE drainage corrugated pipes

## HDPE DRAINAGE CORRUGATED PIPES

The need for water is a basic life requirement. But the uncontrolled flow of water can often cause problems, because effective drainage plays an important role in agriculture and construction of sports facilities, roads and buildings. If appropriate pipes are not placed in proper accordance with the present water and land management, for example while building brick buildings, irreparable damage can be done in a short time. As a result, drainage systems are necessary aspect of any

construction work especially in agriculture and construction of roads and buildings, where we have the optimum protection and treatment of ground water resources.

Corrugated pipes are characterized by their "sandwich" structure. Outer wall of the corrugated pipes provides high rigidity and stability of these pipes, while the smooth inner wall provides optimum water flow speed. Inner and outer wall are connected homogeneous. Water

## HDPE DRAINAGE CORRUGATED PIPES FEATURES

- Material: HDPE
- Standard: DIN 4262/1
- Density:  $>0,945 \text{ kg/m}^3$
- MFI  $190^\circ\text{C}/5\text{Kg}$  0,35-1,3gr/10'
- Elastic modulus  $>800 \text{ MPa}$
- Thermal expansion coefficients:  $0,17 \text{ mm/m}^\circ\text{K}$
- Coefficients of thermal conductivity: na  $23^\circ\text{C}$  - 0,36-0,5 W/mk
- Surface Resistivity:  $>10^{13} \Omega$
- Type of connection through socket without rubber
- Laying of pipelines and the use of HDPE pipelines is between  $-40^\circ\text{C}$  to  $+60^\circ\text{C}$ .
- Ring stiffness  $\text{SN}=4 \text{ KN/m}^2$  (EN ISO 9969)
- Standard color is black

## HYDRAULIC CHARACTERISTICS

The diagram shows the hydraulic characteristics based on the coefficient of rigidness  $k_b = 0.5$

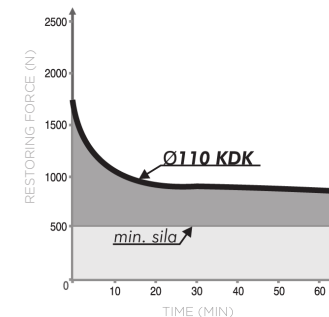
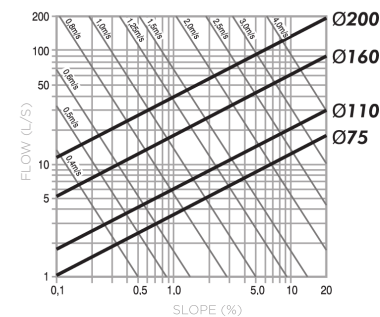

## TYPES OF PIPES

There are three types of drainage pipes made of polyethylene, defined through outside diameter - pipe OD:

- KD - rigid drainage pipes (fully perforated)
- KDK - rigid drainage - sewerage pipes (partially perforated)
- FDK - flexible drainage pipes (fully perforated)

### KD - RIGID DRAINAGE PIPES (FULLY PERFORATED)

KD pipes function is to provide optimum drainage podstepena and anti-freeze layer. This applies both during construction and completion of the works site by entering the existing water and transporting it to the exit spot. The joints are impermeable to sand. It is not necessary to place a rubber. Standard implies 6 slots along the scope with angle of 60°.

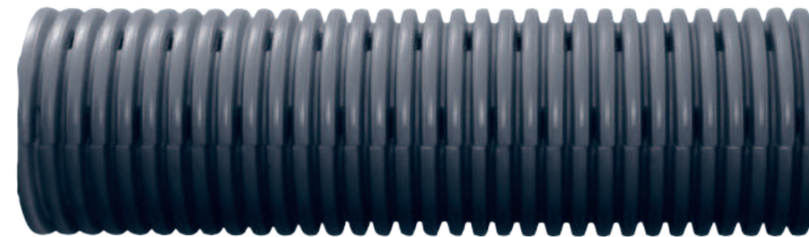
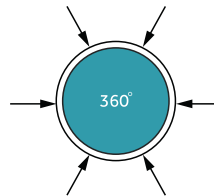

CODE	OUTTER DIAMETER (MM)	INNER DIAMETER (MM)	STANDARD GAP (MM)	SPACE FOR WATER INLET (CM <sup>2</sup> /M)	STANDARD LENGTH (M)
10800000	Ø75	Ø62	1 - 1,4	>50	6
10800001	Ø90	Ø75	1 - 1,4	>50	6
10800002	Ø110	Ø92	1 - 1,4	>50	6
10800003	Ø125	Ø108	1 - 1,4	>50	6
10800004	Ø160	Ø138	1 - 1,4	>50	6
10800005	Ø200	Ø176	1 - 1,4	>50	6
00000000	Ø250	Ø222	1 - 1,4	>50	6
00000000	Ø315	Ø278	1 - 1,4	>50	6
00000000	Ø400	Ø348	1 - 1,4	>50	6
00000000	Ø500	Ø432	1 - 1,4	>50	6

## KDK – RIGID DRAINAGE – SEWERAGE PIPES (PARTIALLY PERFORATED)

Partially perforated KDK rigid drainage-sewerage pipes are perfect combination of perforated and collecting pipe. If requested, they must be able to collect and transport any surface water

that occurs, the short and long distances. Joints are impervious to water and sand because of the transport. Rubber is inserted into the third channel of the corrugated pipe and the socket

is slipped over the lubricated rubber. The pipes must be professionally installed by respecting the guidelines for laying of pipelines specified 1610 DIN4033.

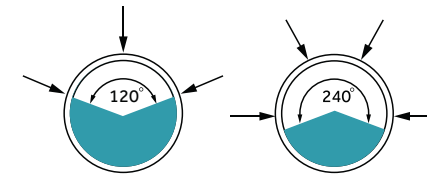
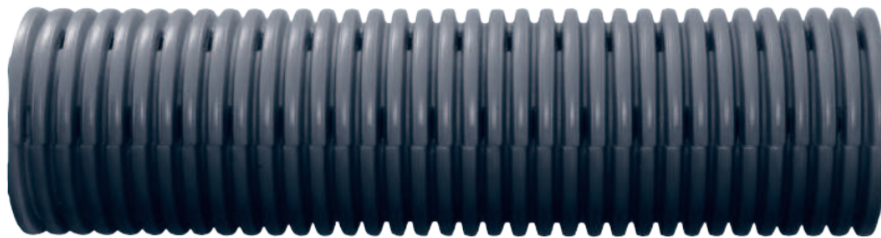

CODE 220°	CODE 150°	OUTTER DIAMETER (MM)	INNER DIAMETER (MM)	STANDARD GAP (MM)	SPACE FOR WATER INLET (CM <sup>2</sup> /M)	STANDARD LENGTH (M)
10800100	10800200	Ø75	Ø62	1 - 1,4	>50	6
10800101	10800201	Ø90	Ø75	1 - 1,4	>50	6
10800102	10800202	Ø110	Ø92	1 - 1,4	>50	6
10800103	10800203	Ø125	Ø108	1 - 1,4	>50	6
10800104	10800204	Ø160	Ø138	1 - 1,4	>50	6
10800105	10800205	Ø200	Ø176	1 - 1,4	>50	6
00000000	00000000	Ø250	Ø222	1 - 1,4	>50	6
00000000	00000000	Ø315	Ø278	1 - 1,4	>50	6
00000000	00000000	Ø400	Ø348	1 - 1,4	>50	6
00000000	00000000	Ø500	Ø432	1 - 1,4	>50	6



## FDK – FLEXIBLE DRAINAGE PIPES (FULLY PERFORATED)

These pipes are light, highly flexible, resistant to UV light, solid and economical, easy to assemble. Due to special production process, the inner side of the pipe is smooth while the outer side is corrugated. The pipes are continued with coupling, which is impervious to sand. Application

temperature is from -40 °C to +60 °C. They are made of a material HDPE/LDPE. Gaps make > 50cm<sup>2</sup>/m of the water entrance surface. The slots are placed symmetrically in each channel of corrugated pipe. They are laid faster and better automatically. While settling, the pipes can be

encased with filter material. The role of filters is to increase throughput and prevent rapid clogging pipes. It is possible to choose the number of slots for entry of water. Standard color is black and yellow-black. Other colors are possible by demand. They are packed and shipped in 50 m long coils.

**IT IS POSSIBLE TO CHOOSE THE NUMBER OF SLOTS FOR ENTRY OF WATER.**

On request peřtan is able to produce rigid drainage – sewerage pipes (partially perforated) with bigger perforation 50-200cm<sup>2</sup>/m for diameters from ø75-ø315

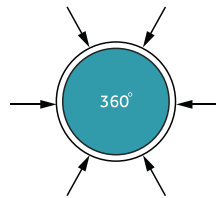

CODE	OUTTER DIAMETER (MM)	INNER DIAMETER (MM)	STANDARD GAP (MM)	SPACE FOR WATER INLET (CM <sup>2</sup> /M)	STANDARD LENGTH (M)
10800500	ø75	ø62	1 - 1,4	>50	100
10800501	ø90	ø75	1 - 1,4	>50	100
10800502	ø110	ø92	1 - 1,4	>50	50
10800503	ø125	ø108	1 - 1,4	>50	50
10800504	ø160	ø138	1 - 1,4	>50	50
10800505	ø200	ø176	1 - 1,4	>50	50
00000000	ø250	ø222	1 - 1,4	>50	6
00000000	ø315	ø278	1 - 1,4	>50	6
00000000	ø400	ø348	1 - 1,4	>50	6
00000000	ø500	ø432	1 - 1,4	>50	6

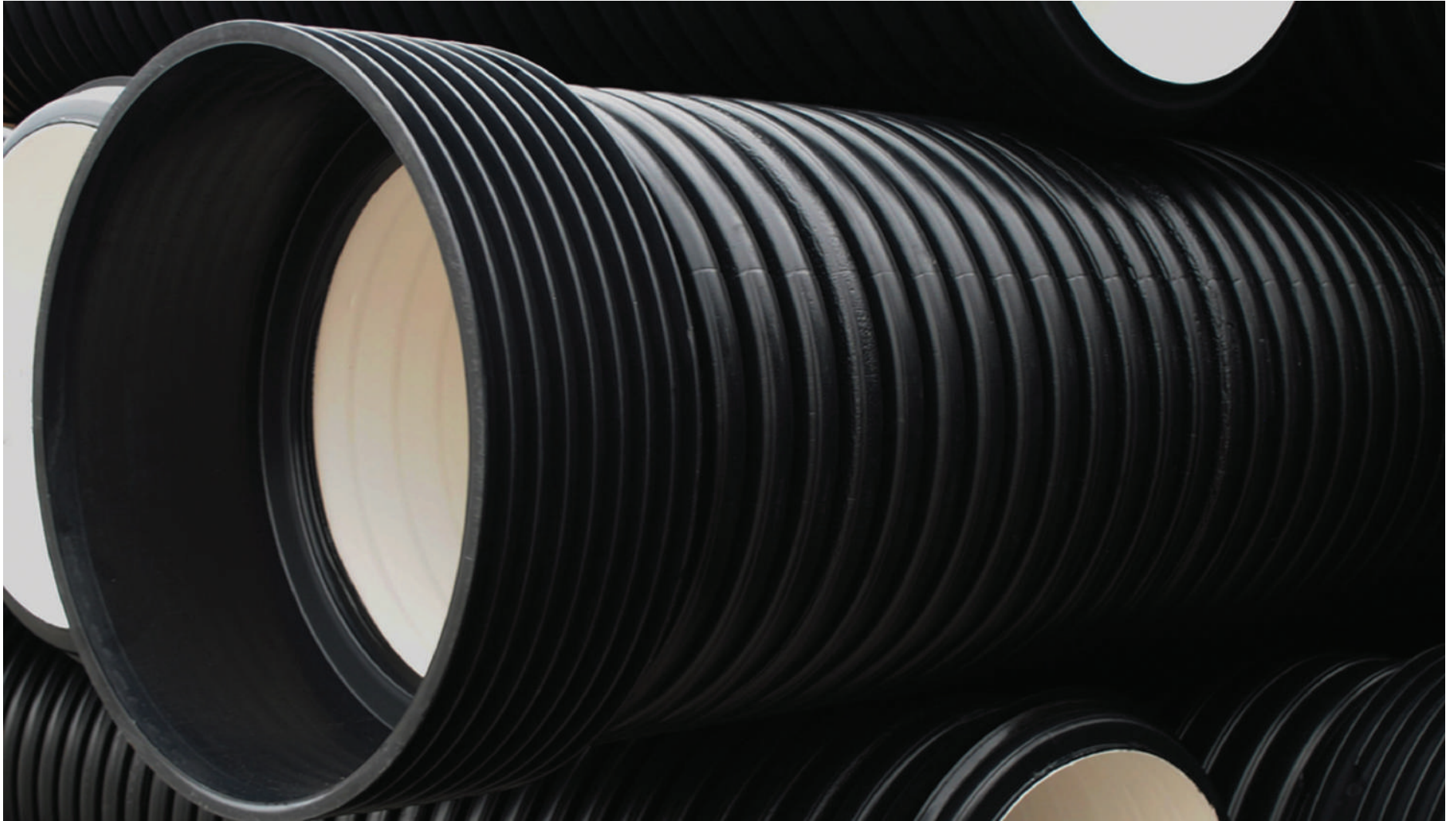

# HDPE ID DRAINAGE PIPES

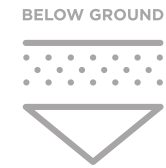

Polietylene corrugated ID drainage pipes

Excess water in the soil can cause serious problems on land and objects in landslides and in very short period of time until their complete destruction. Therefore, the proper drainage of the terrain is extremely important before we have to design and prepare the ground for construction. Having in mind the need for drainage of excess water from the soil Peštan in its production program it is included a large range of diameters in accordance with DIN 4262/1 corrugated drainage and polyethylene (PE) pipe to drain excess water from the soil. Thanks to its large hydraulic capacity and a wide range of diameters these pipes are fully able to respond to any request and to provide a reliable and long-term drainage field.

HDPE pipes are lighter than PVC pipes and they are used for the same purpose, which allows easier handling and installation, they have excellent chemical resistance to aggressive environments and the surrounding land. Placing and use of HDPE pipeline is from  $-40^{\circ}\text{C}$  up to  $+60^{\circ}\text{C}$ . The smooth inner surface has a low coefficient of friction so the pipes have very good hydraulic characteristics. They have excellent resistance to abrasion and they have excellent mechanical and physical properties.

Pipes are resistant to UV rays, they can stand a year outdoors and they should be protected. It is necessary to take into account that during transport and installation the pipes must not be dragged over sharp edges because sharp edges can damage the pipe while they are impact-resistant on blunt instrument.

## CHARACTERISTICS AND SPECIFICATIONS

---

- Material: PE-HD (high-density polyethylene)
- Fast and inexpensive assembling
- Standard: DIN 4262/1
- Density:> 0,945 Kg / m<sup>3</sup>
- Index dispensing MFI 190 ° C / 5kg 0,35-1,3 gr / 10 '
- Modulus of elasticity:> 800 MPa
- The coefficient of linear thermal expansion: 0,17mm / mK
- The coefficient of thermal conductivity at 23 ° C - 0,36-0,5W / mk
- Surface electrical resistance:> 10<sup>13</sup>Ω
- Connection through via a socket
- Ring hardness SN = 4kN / m<sup>2</sup> I = SN 8 kN / m<sup>2</sup>
- Color: Black standard (at the request of the customer as well as some other color)
- Standard length 6 and 12m



PEŠTAN has all the necessary fittings for installation of pipes

## TYPES OF HDPE ID DRAINAGE PIPES

DN / ID (nominal diameter is inner diameter of the inside-diameter) double wall corrugated HDPE pipes are classified according to internal diameter.

They are manufactured with integrated socket.

They can work in a range from Ø140 to Ø800, stiffness SN 4 and SN 8th



ID SN4



ID SN8

DN		OD (mm)	ID (mm)	e (mm)	CWT (mm)	LWT (mm)	T (mm)	A (mm)	Kg/m
Ø140	SN4	Ø160	139.8	1.2	0.5-0.9	0.9	17.44	3.5	0.8-1.1
	SN8	Ø160	139	1.6	0.9-1.2	1.1	17.44	3.5	1.1-1.4
Ø200	SN4	Ø227	199	1.7	0.9-1.2	1.2	22.43	4.5	1.8-2.0
	SN8	Ø227	198	2.2	1.2-1.6	1.4	22.43	4.5	2.1-2.5
Ø250	SN4	Ø283	249	2.2	1.2-1.4	1.5	26.17	5.1	2.8-3.1
	SN8	Ø283	248	2.7	1.6-2.0	1.6	26.17	5.1	3.6-3.85
Ø300	SN4	Ø340	298.2	2.6	1.3-1.5	1.7	31.4	5.5	3.8-4.2
	SN8	Ø340	297	3.2	1.7-2.2	1.8	31.4	5.5	4.5-5.2
Ø400	SN4	Ø453	397.8	3.2	1.4-1.7	2.2	39.25	7.9	5.8-6.6
	SN8	Ø453	396	4.1	2.2-2.6	2.5	39.25	7.9	8.1-8.9
Ø500	SN4	Ø567	497.6	4.2	1.8-2.2	3.0	52.78	9.4	9.8-10.7
	SN8	Ø567	495	5.5	2.4-3.1	3.3	52.78	9.4	12.6-13.5
Ø600	SN4	Ø680	597	5.2	2.6-3.0	3.5	65.97	13.2	15.0-16.5
	SN8	Ø680	594	6.7	3.4-3.8	3.8	65.97	13.2	18.7-19.3
Ø800	SN4	Ø906	796	6.5	2.8-3.2	4.5	89.97	19.3	24.0-25.8
	SN8	Ø906	792	8.5	4.3-5.1	4.7	89.87	19.3	31.6-33.4

There are two types of drainage pipes made of polyethylene, defined through inside diameter - pipe ID:

- **KD** - RIGID DRAINAGE PIPES (FULLY PERFORATED)
- **KDK** - RIGID DRAINAGE-SEWERAGE PIPES (PARTLY PERFORATED)

## KD - RIGID DRAINAGE PIPES (FULLY PERFORATED)

---

KD pipes has to assure the function of optimum drainage degree and anti-freeze layer.

This is applied for both during the construction and completion of work construction site by entering of the existing water and transporting it to the main dumping. The joints are impermeable on sand. Installation of rubber for compounds for these pipes are not necessary.

Standard are 6 slots per Celma diameter volume distributed up to 60°.

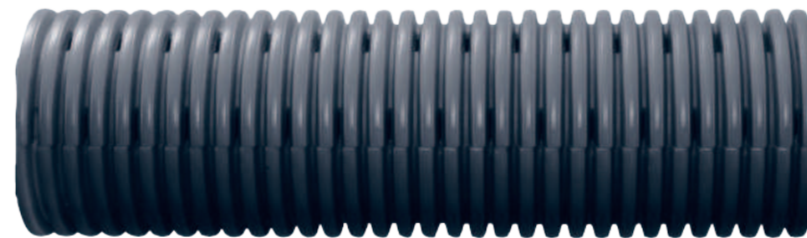
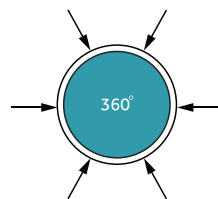

## KDK - RIGID DRAINAGE PIPES (PARTIALLY PERFORATED)

Partially perforated KDK stiff drainage-sewerage pipes represent the ideal combination of perforated and collected pipes. If its necessary, they must be able to collect and transport any surface water which at short and long distances. Joint is impermeable to water and sand because of water transport. Eraser is inserted into the third channel of corrugated pipes. The greased socket is inserted over the greased rubber.

The pipes must be professionally installed respecting the directions for laying of the pipeline given in 1610 and DIN 4033.

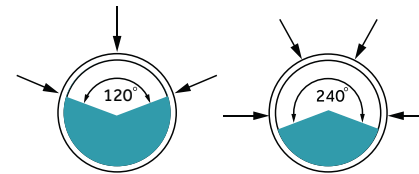
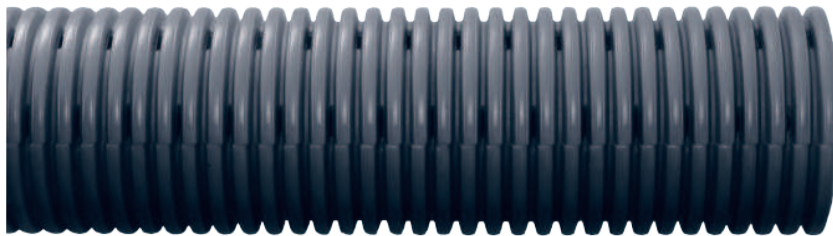

The slots on both types of pipes are located between the ribs. Pipe has to be symmetrically in volume over the length of the tube which does not allows impeded access of water to the slit. During the construction of drainage systems it is recommended to put the pipe in the stone filter layer except if is placed in an additional protective layer of geotextile filter to prevent leaching of the soil and the possible blocking of the hole on the tube impurities and therefore I reduced efficiency of the pipeline.







# PP ID DRAINAGE PIPES



Polypropilene corrugated drainage pipes ID

Excess of water in the soil can cause serious problems on land and objects until their complete destruction in landslides in a very short period of time. Therefore, the proper drainage of the terrain is extremely important to consider when designing and preparing the ground for construction.

Bearing in mind the need for drainage of excess water from the soil, Peštan included corrugated drainage and polypropylene (PP) pipes in its production portfolio. Peštan provides a large range of diameters in accordance with DIN 4262/1. These pipes, thanks to their large hydraulic capacity and a wide range of diameters, are fully able to respond to any request and provide a reliable and long-term drainage of ground. In addition, thanks to the chemical resistance of polypropylene, these pipes are used even in the presence of chemically aggressive liquids.

Peštan polypropylene corrugated drainage pipes are made from standard PP corrugated pipes. The pipes are passing through perforation process in accordance with DIN 4262/1.

PP pipes are lighter than PVC pipes for the same purpose, which provides easier handling and installation. They have excellent chemical resistance to aggressive environment and the surrounding land. The smooth inner surface has a low coefficient of friction so that the pipes have very good hydraulic characteristics. They have excellent resistance to abrasion, mechanical and physical properties.

Pipes are resistant to UV rays- they can stand outdoors for one year. They should be protected. It is necessary to take into account that during transport and installation pipes shouldn't be dragged over sharp edges, sharp edges can damage the pipe while they are impact-resistant to blunt instrument.

## FEATURES AND TECHNICAL DATA

---

- Material: PP-B copolymer
- Fast and inexpensive mounting
- Standard: DIN 4262/1
- Density:  $>0,900 \text{ Kg/m}^3$
- Pour Index: MFR 230 C/2.16 0,30 gr/10'
- Modulus of elasticity: MPa 1500/2000
- Tensile strength: 32 MPa
- Impact strength according to Charpy: at  $23 \text{ }^\circ\text{C}$   $\approx 70 \text{ kJ/m}^2$ ; at  $-23 \text{ }^\circ\text{C}$   $\approx 7 \text{ kJ/m}^2$
- Connection is via a socket
- Ring hardness SN =  $4 \text{ kN/m}^2$  I = SN  $8 \text{ kN/m}^2$
- Colour: orange Standard (by request of the customer can have other colors)
- Standard length 6 and 12 m

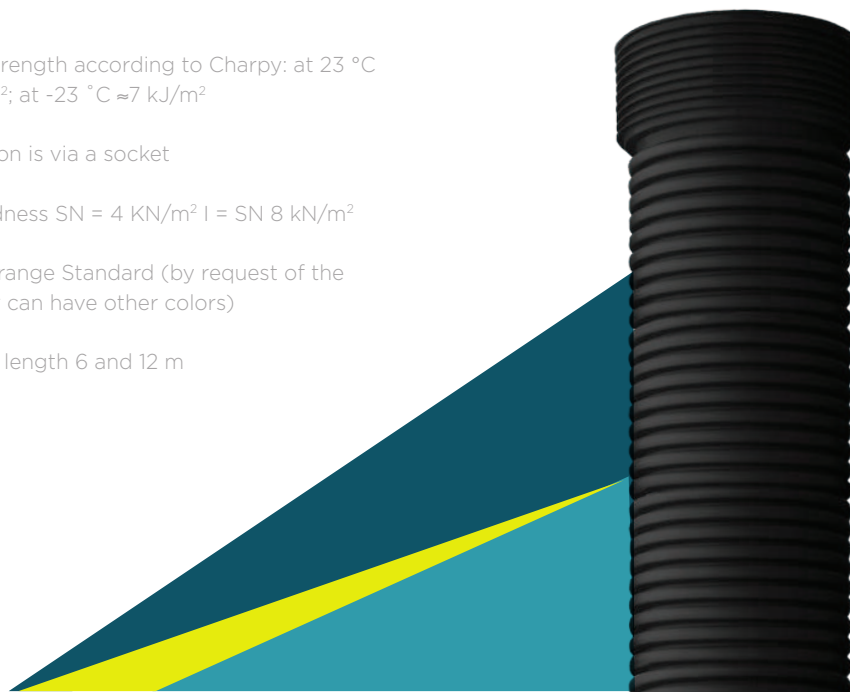

## TYPES OF PP ID DRAINAGE PIPES

Double-layer corrugated PP pipe have been classified by the internal diameter of DN/ID (nominal diameter is the inner diameter/ inside-diameter).

They are manufactured with integrated socket.They can be produced in a range from Ø140 to Ø800, of ring stiffness SN 4 and SN 8.

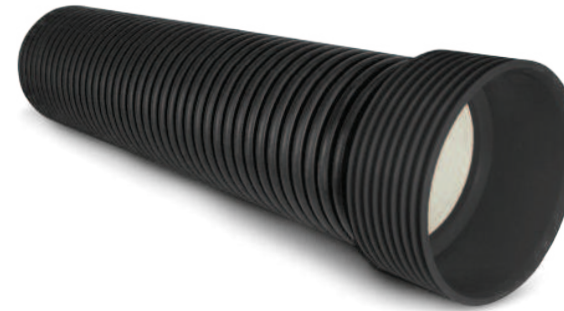

DN		OD (MM)	ID (MM)	E (MM)	CWT (MM)	LWT (MM)	T (MM)	A (MM)	KG/M
Ø140	SN4	Ø160	139.8	1.2	0.5-0.9	0.9	17.44	3.5	0.8-1.1
	SN8	Ø160	139	1.6	0.9-1.2	1.1	17.44	3.5	1.1-1.4
Ø200	SN4	Ø227	199	1.7	0.9-1.2	1.2	22.43	4.5	1.8-2.0
	SN8	Ø227	198	2.2	1.2-1.6	1.4	22.43	4.5	2.1-2.5
Ø250	SN4	Ø283	249	2.2	1.2-1.4	1.5	26.17	5.1	2.8-3.1
	SN8	Ø283	248	2.7	1.6-2.0	1.6	26.17	5.1	3.6-3.85
Ø300	SN4	Ø340	298.2	2.6	1.3-1.5	1.7	31.4	5.5	3.8-4.2
	SN8	Ø340	297	3.2	1.7-2.2	1.8	31.4	5.5	4.5-5.2
Ø400	SN4	Ø453	397.8	3.2	1.4-1.7	2.2	39.25	7.9	5.8-6.6
	SN8	Ø453	396	4.1	2.2-2.6	2.5	39.25	7.9	8.1-8.9
Ø500	SN4	Ø567	497.6	4.2	1.8-2.2	3.0	52.78	9.4	9.8-10.7
	SN8	Ø567	495	5.5	2.4-3.1	3.3	52.78	9.4	12.6-13.5
Ø600	SN4	Ø680	597	5.2	2.6-3.0	3.5	65.97	13.2	15.0-16.5
	SN8	Ø680	594	6.7	3.4-3.8	3.8	65.97	13.2	18.7-19.3
Ø800	SN4	Ø906	796	6.5	2.8-3.2	4.5	89.97	19.3	24.0-25.8
	SN8	Ø906	792	8.5	4.3-5.1	4.7	89.87	19.3	31.6-33.4

There are two types of drainage pipes made of polypropylene, defined through the inner diameter – ID pipes:

- **KD** – RIGID DRAINAGE PIPES (FULLY PERFORATED)
- **KDK** – RIGID DRAINAGE-SEWERAGE PIPES (PARTLY PERFORATED)

## KD - RIGID DRAINAGE PIPES (FULLY PERFORATED)

---

KD pipes function is to assure the optimum drainage sub-degree and anti-freeze layer.

This applies both during the construction and completion of the work site by entering the existing water and transporting it to the main dumping.

The joints are impermeable to sand.

Installation of rubber rings to such pipes is not necessary. 6 slots are standard per whole volume and they are distributed to 60°.

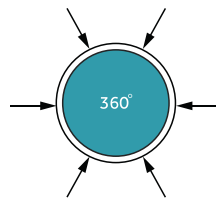

## KDK - RIGID SOLID DRAINAGE PIPES (PARTIALLY PERFORATED)

Partially perforated KDK solid drainage-sewerage pipes represent the ideal combination of perforated and collecting pipes. If requested, they must be able to collect and transport any surface water at short and long distances. Because of water transport, sockets are impermeable to water and sand. Rubber ring is inserted into the third channel of the corrugated pipe and socket, which is first lubricated, is wrapped around lubricated rubber. The pipes must be professionally installed respecting the guidelines for laying the pipeline given in EN1610 and DIN4033.

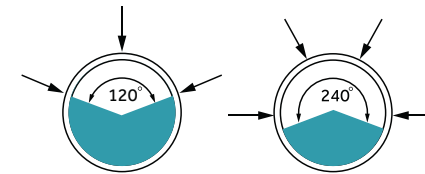

The slots on both types of pipes are located between the ribs of pipe, symmetrically over whole volume of the pipe which allows a smooth access of water to the slot. During the construction of drainage systems it is recommended to place a pipe, in addition to the stone filter layer, in an additional protective layer of geotextile filter to prevent leaching of the soil and the possible blocking of the hole on the pipe impurities and therefore reduction of efficiency of the pipeline.

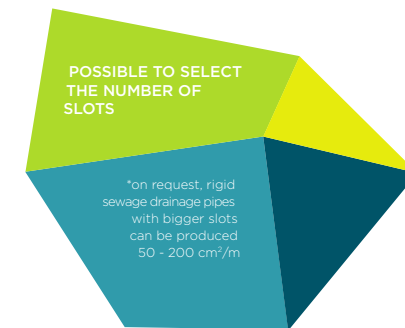

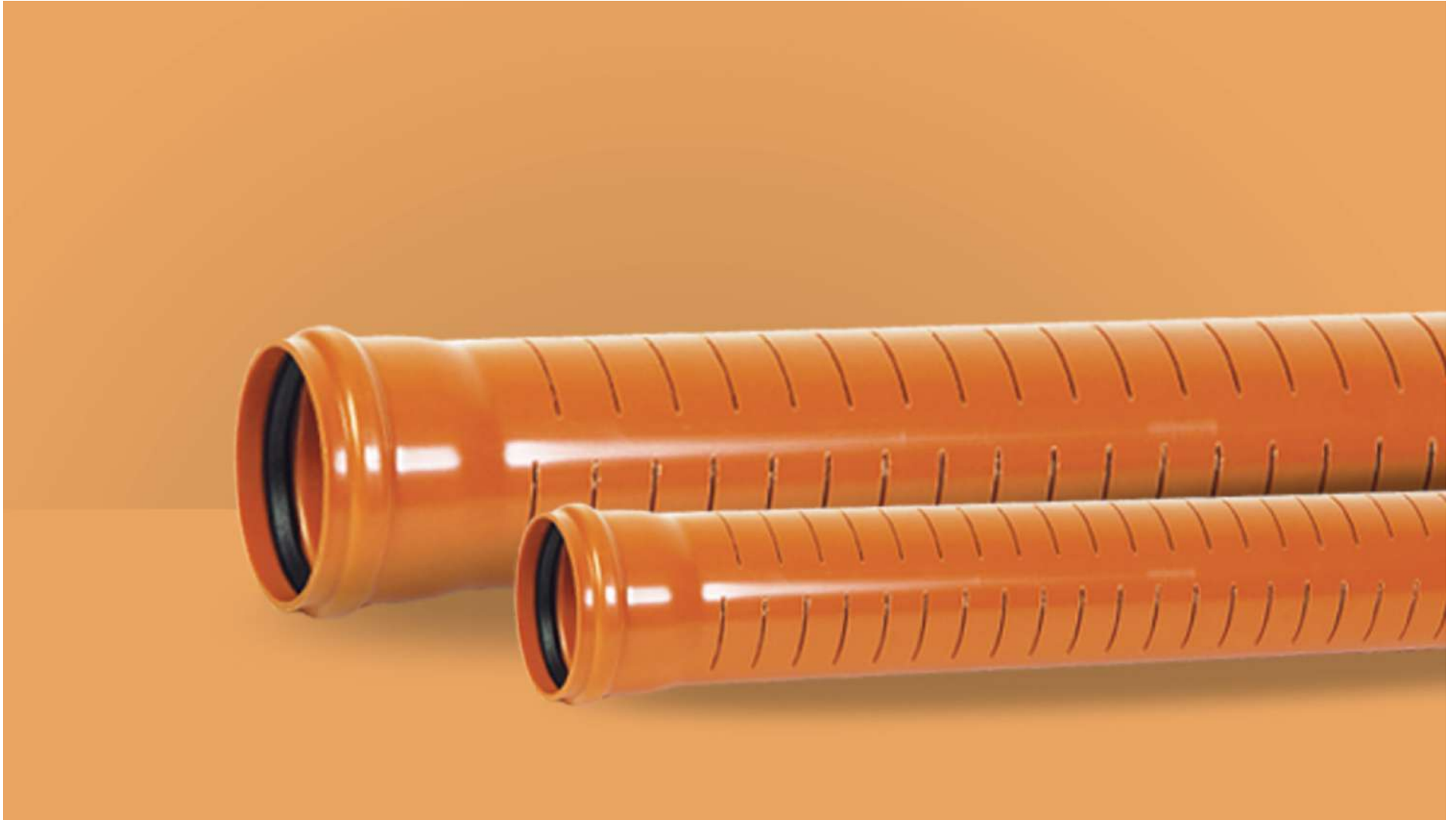

# PVC DRAINAGE PIPES

BELOW GROUND



PVC perforated drainage pipes

## KG (PVC) PERFORATED PIPES

**Perforated PVC pipes for drainage have been manufactured according to DIN 4262 standard.**

Assembly of the pipeline is extremely easy , pipes are connected to one another with fittings while complete seal is achieved with use of rubber bands. Maximum temperature of application is +60 °C. Pipes are resistant to salt water, alcohol, acids, alkalis, sulphates, aggressive gas and all kinds of detergents. On the other hand, they cannot be used for the transport of water which contains high percentage of benzene, benzine (petrol) or acetone.

## ADVANTAGES & OWNER BENEFITS

- Very light material
- Simple and easy way of both transport and manipulation
- Fast and cheap assembling
- Pipe connections are resistant to water and other type of fluids
- They are resistant to corrosion in alkaline, acid or aggressive environment
- They are fine electrical insulator, and also resistant to mechanical impact
- Guaranteed life time of more than 50 years
- Connection with muffs and gaskets made of EPDM or rubber (EN 681)
- SRPS EN 1401 - compact; SRPS EN 13476 - Three-Layered



The method of producing perforations in the PVC pipes



## SPECIFICATION OF MATERIAL



PVC-pipes and fittings are made from compound of non-softened PVC material with = 10MPa mixed with necessary additives.  
Specific mass  $1,38 \div 1,45 \text{ gr/cm}^3$

- Typical weight  $1.38 \div 1.45 \text{ g/cm}^3$
- Tensile strenght 50-60 MPa
- Thermal stability:  
according to Vicat min 79 °C
- Thermal conductivity  $0,54 \text{ KJ/mh/}^\circ\text{C}$
- Linear ratio of thermal extension  $0,08 \text{ mm/m/}^\circ\text{C}$
- Water absorption  $4 \text{ mg/cm}^2$

## PIPE SERIES SPECIFICATION

---

### Pipe series S-20 (SDR 41) SN 4 KN/m<sup>2</sup>

- Depth of pipe trench min 1,2 ÷ 6 m max
- Maximum loading max 18 t/axel
- Ring stiffness SN 4 KN/m<sup>2</sup>
- Connection with EPDM or rubber (EN 681) seal in socket
- Length 1 ÷ 6m

### Pipe series S-16 (SDR 34) SN 8 KN/m<sup>2</sup>

- Depth of pipe trench min 1,2 ÷ 6 m max
- Maximum loading max 18 t/axel
- Ring stiffness SN 8 KN/m<sup>2</sup>
- Connection with EPDM or rubber (EN 681) seal in socket
- Length 1 ÷ 6 m

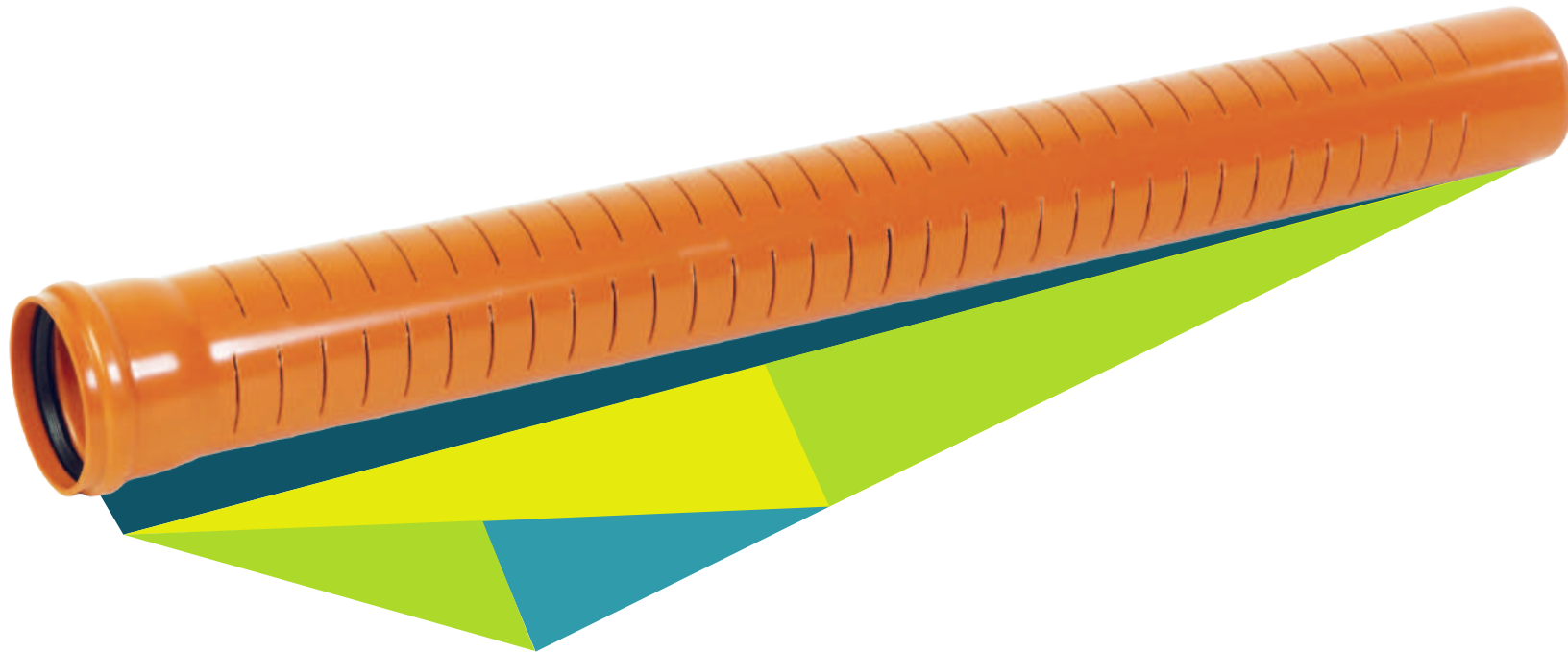

Ø110 pipe - perforated in 3 rows  
 Ø125 pipe - perforated in 3 rows  
 Ø160 pipe - perforated in 3 rows  
 Ø200 pipe - perforated in 4 rows

Ø250 pipe - perforated in 5 rows  
 Ø315 pipe - perforated in 6 rows  
 Ø400 pipe - perforated in 7 rows

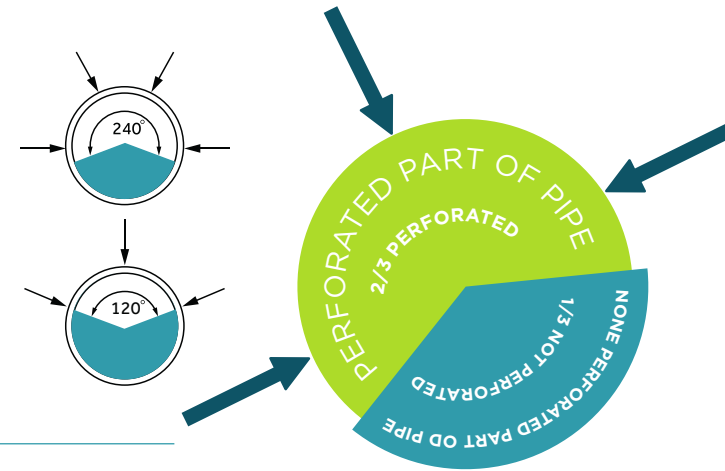

### ILLUSTRATED EXAMPLE OF PERFORATED PIPE

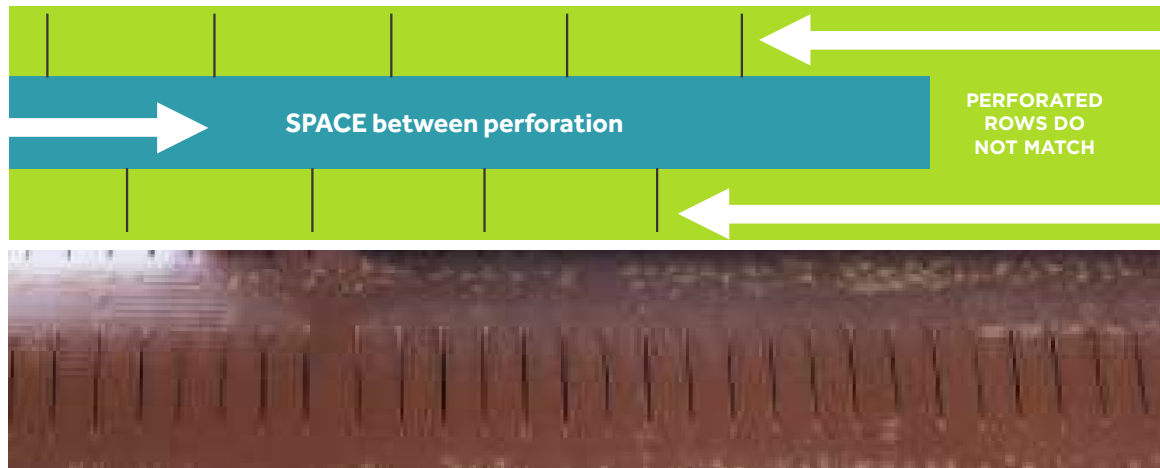

The slots are such as to allow unrestricted entry of water into the pipe. Their position is normal to the axis of the tube. Slot width in the perforated pipe is from 2.5 to 3 mm. Area slit the water intake is greater than 50 cm/m<sup>2</sup>.

### DISTANCE BETWEEN CUTS

From 15 mm to 20 mm on pipes Ø110 and Ø125  
 From 20 mm to 25 mm on pipes Ø160

From 25 mm to 30 mm on pipes Ø200 and Ø250  
 From 35 mm to 40 mm on pipes Ø315  
 From 45 mm to 50 mm on pipes Ø400

## PIPES ACCORDING TO DIN 4262 STANDARD SHALL BE CATEGORIZED IN THE FOLLOWING WAYS ACCORDING TO THEIR ARRANGEMENT OF THE SLOTS AS SHOWN IN PICTURE:

**a) Totally perforated pipes (TP)** are arranged uniformly over the entire circumference of the water inlet opening and having at least four rows of slots. They may be used in all sizes. Tubes of the type C1 and C2 are not produced as pipes.

**b) Locally perforated pipes (LP)** in which the water inlet opening is arranged over a range of about 220 degrees  $\pm 10$  at the pipe apex symmetrically to the vertical axis of the pipe, and the sole is unslotted. It must have at least three rows of slots. They are usually available in nominal sizes DN100 eingestetzt to DN200.

**c) Multi purpose pipes (MP)** in which the water inlet opening is arranged on top of the pipe symmetrically to the vertical pipe axis evenly over a range of maximum 120 degrees, have at least two rows of slots and have a watertight connection. The lower part of the MP-pipe can be used as transport pipe for all of the water. They are used in nominal diameters from DN200.

**d) Unperforated transport pipe (UP)**

**THE INSTALLATION POSITION OF THE TP AND MP-PIPES MUST BE RECOGNIZABLE EITHER BY THE SHAPE OF THE PIPE OR BY A CROWN MARK.**

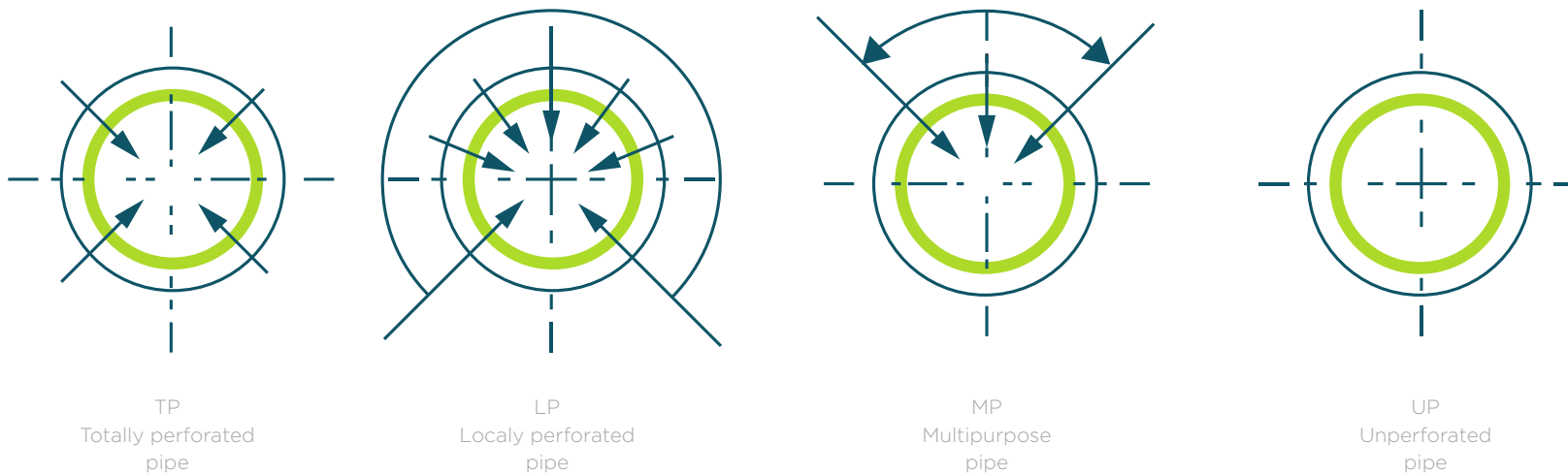





# CABLE PROTECTION





# SINGLE LAYER CORRUGATED PIPES

---



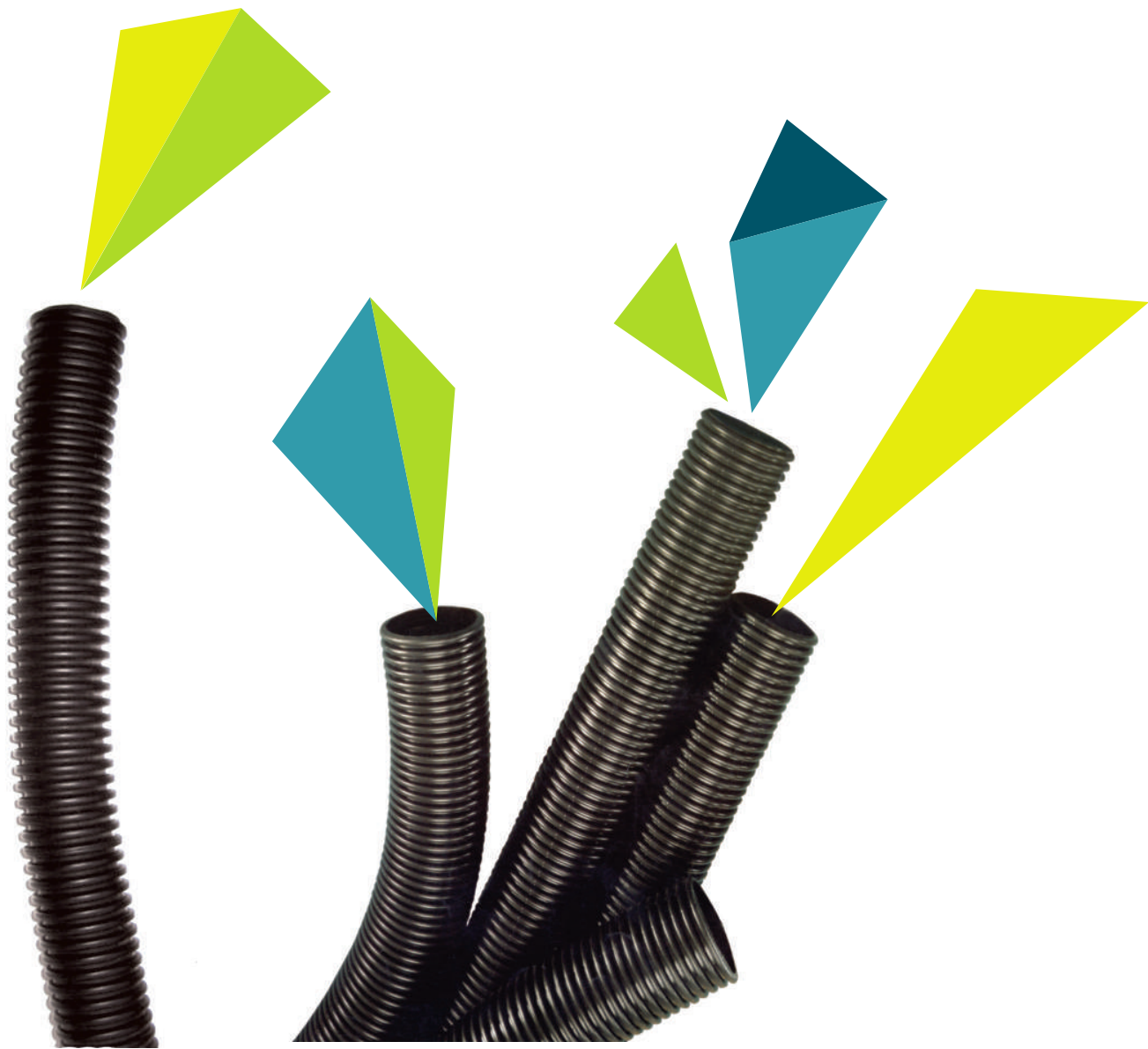

## SINGLE LAYER ELECTRO INSULATING CORRUGATED “THROAT” PIPES

---

They are used for power and PTT installations in industrial and construction building. They are placed in the mortar and in concrete layer. Cables can be inserted quickly and easily inside the pipes, even on curved surface. These pipes are produced in accordance with DIN49018

CODE	OUTSIDE DIAMETER MM	INSIDE DIAMETER MM	MIN INSIDE DIAMETER WHEN BENDED MM
10900101	Ø20	Ø14	100
10900102	Ø25	Ø19	50
10900103	Ø32	Ø25	50



# PVC PTT AND EL-EN PIPES

BELOW GROUND



PVC Pipes for cable protection

## PVC PIPES FOR CABLE SYSTEMS

- Light material, easy and quickly to storage and manipulate;
- Easy to transport, simple and cheap assembling process;
- The process of connecting two PVC pipes doesn't last for more than 1 minute, there for the interruptions of the traffic do not last very long;
- They have thin walls, so that the laying of the cables inside the pipes is very swift and simple;
- In the same trench a large number of pipes can be laid next and on top of each other;
- Connections are impermeable to water and any other fluids;
- They are resistant to corrosion in alkaline, acid or any other aggressive environment;
- They are fine electrical insulators and also resistant to stray currents;
- They're resistant to impact;
- They are resistant to ageing (with the life time of more than 50 years);
- Pipe dimensions are 110 mm, 125 mm, 160 mm 200 mm with the length of 6 m;
- They're produced in yellow and red color.

These pipes are produced out of PVC, according to EN 1401 and EN 13476. Standard production length is 6 m. They can be continued with the socket and rubber bend which is water, sand and dust impermeable. Pipes are produced in standard colors: yellow for PTT cables and red for electro energetic installations.

PVC PIPES				
CODE	COLOR	OUTSIDE DIAMETER (DC)	INSIDE DIAMETER	WALL THICKNESS (S)
11400011	Red	110+0,3	110,6-0,2	3,2+0,5
		125	118,6	3,7
		160	152	4,7
		200	190,2	5,9
	Yellow	110+0,3	110,6-0,2	3,2+0,5
		125	118,6	3,7
		160	152	4,7
		200	190,2	5,9

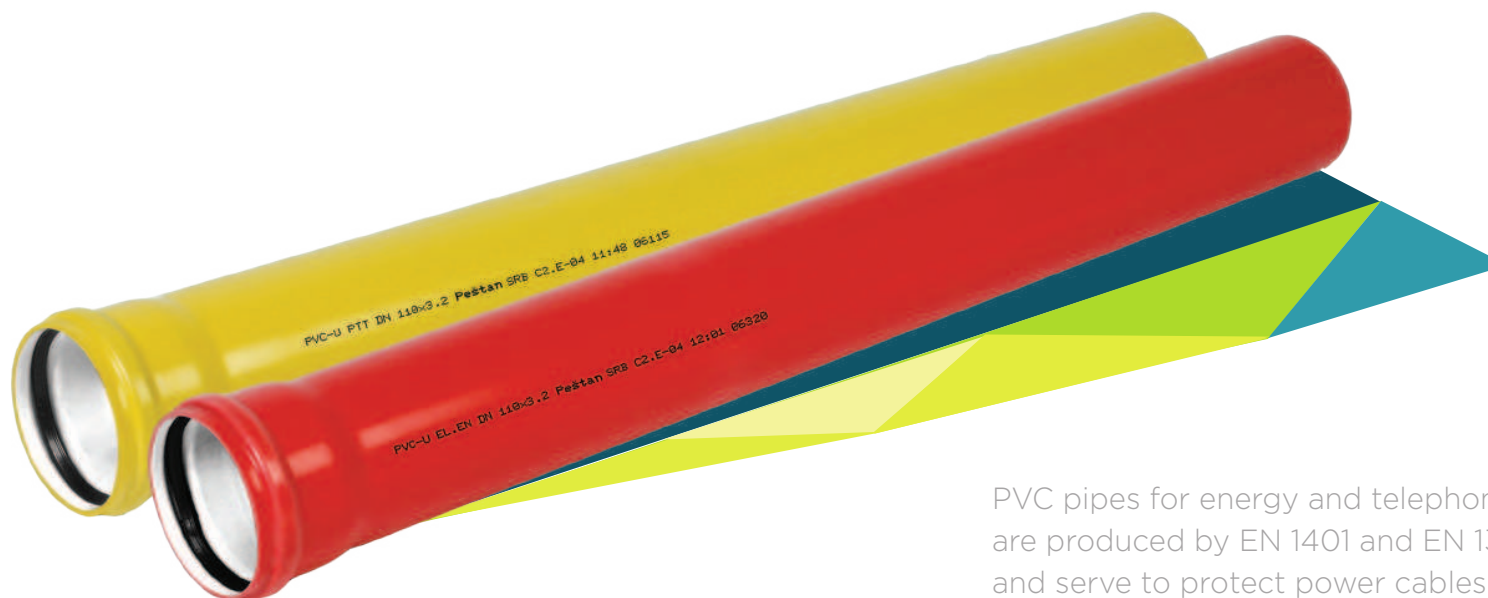
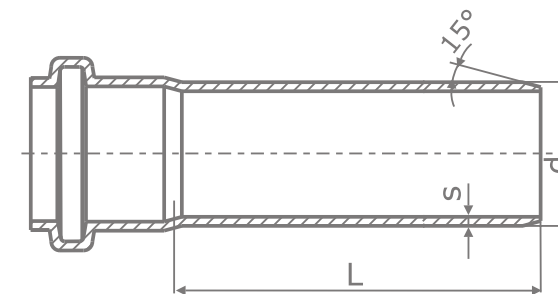
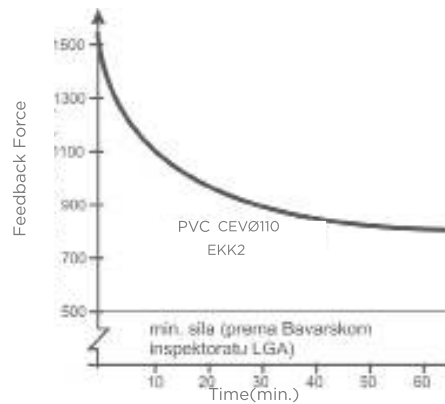
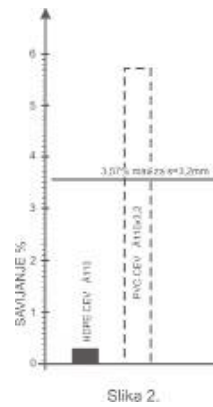
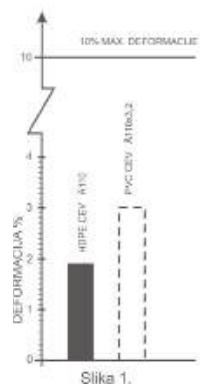

PVC pipes for energy and telephone cables are produced by EN 1401 and EN 13476, and serve to protect power cables.





# HDPE CORRUGATED CABLE PROTECTION PIPES

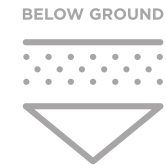

Polyethylene double-layered corrugated pipes for cable protection

Pipes are prepared by SRPS-EN12201, DIN8074-8075, ISO 4427 and ISO 4065

HDPE PE-80	
CODE	D (MM)
11199202	Ø50
0000000	Ø75
11199205	Ø90
11199206	Ø110
0000000	Ø125
0000000	Ø160
0000000	Ø200



# SMOOTH PIPES FOR CABLE PROTECTION

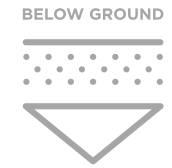

Polyethylene smooth pipes for cable protection

Are prepared by SRPS-EN12201, DIN8074-8075, ISO 4427 and ISO 4065

HDPE PE-80	
CODE	D (MM)
11199198	Ø20
11199200	Ø32
11199201	Ø40
11199202	Ø50
00000000	Ø63
00000000	Ø75
11199205	Ø90
11199206	Ø110



HDPE cable protection pipes are made of high quality polyethylene PE 80. They are produced in black color and have 4 coextruded light purple lines, which are arranged around the perimeter of the tube. HDPE cable protection pipes have a smooth outer surface and the inner surface of the pipe is with grooves. HDPE cable protection pipes are UV stable.





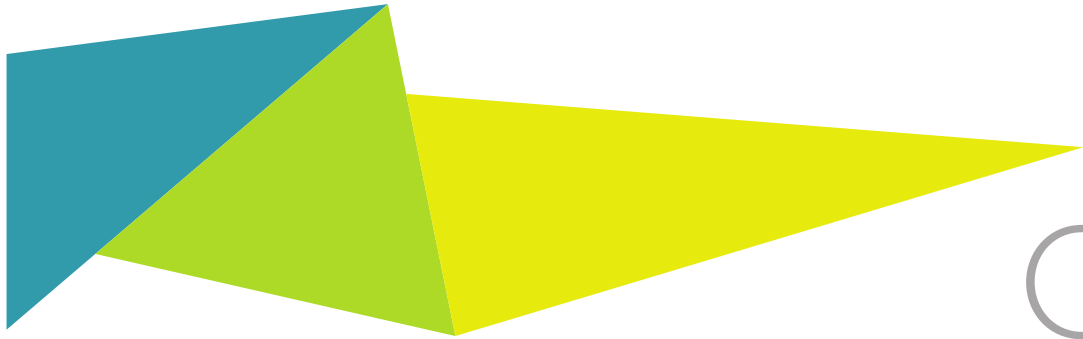

# OUTDOOR DRAINAGE



**VEDRO**



# VEDRO OUTDOOR DRAIN

---

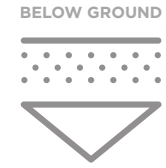

Horizontal atmospheric drain for drainage of the surface water and rainwater.



Vedro outdoor drain A15 with metal grid

The Vedro drain is intended for draining surface water in external sewage systems. Thanks to the adequate performance and design of the drain, as well as high durability, drainage is carried out in the most efficient way

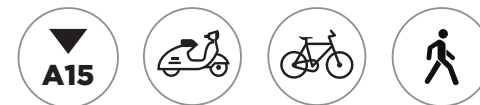

MAIN ADVANTAGES:

- High quality and reliability - standard EN 1433
- Two openings on the side for pipes DN 50 mm and on the bottom side DN 75 and 110 mm
- Effective removal of rainwater from external surfaces
- Massive ribs for structural strength
- System with four fixing points for the base
- Modularity in the continuation of drains in L, X, T, I shapes for additional practicality

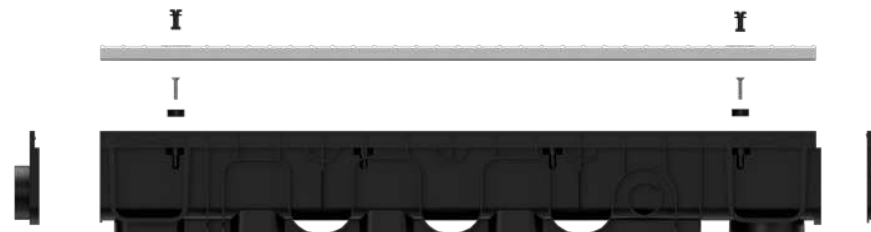

Connection options:

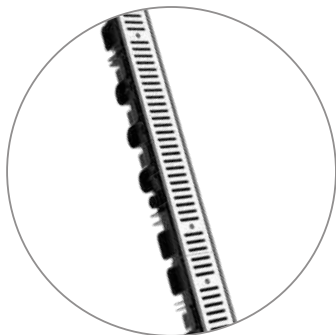

I CONNECTION

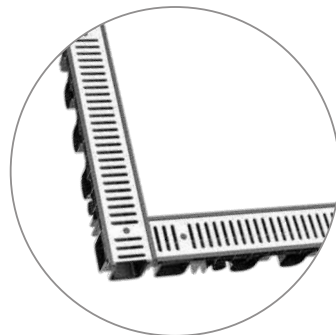

L CONNECTION

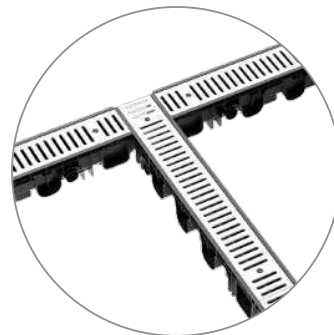

T CONNECTION

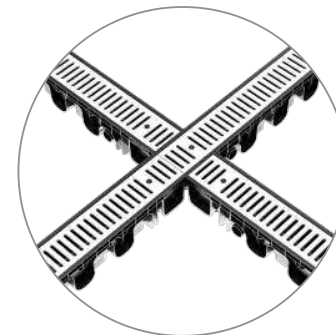

X CONNECTION

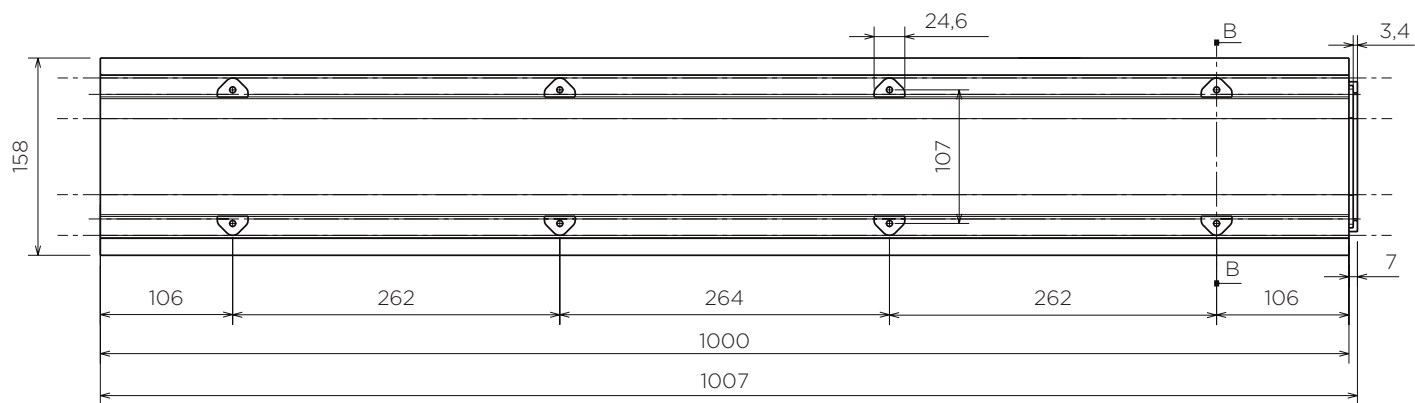

FULL NAME OF PRODUCT	CODE
VEDRO OUTDOOR DRAIN A15 METAL GRID	13705000



# VEDRO GUTTER DRAIN

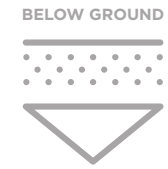

Vertical atmospheric drain for drainage of the surface water and rainwater.

## GENERAL CHARACTERISTICS

---

Made of polypropylene, the product is intended and designed for adequate drainage of surface water (rainwater) in external sewage systems. The drain allows the connection of gutter pipes of different diameters. The drain pipe connection includes 2 options (110 and 125 mm), which are used depending on the pipeline to which the drain is connected.

The gutter drain contains a dry valve that blocks the entry of pests from the pipeline, as well as a basket (leaf catcher) which maximally simplifies and facilitates cleaning. The design also enables the connection of different diameters of gutter pipes in a simple way, by cutting the appropriate diameters to DN50, DN75, DN90 DN110, and DN125.

**FULL PRODUCT NAME:** GUTTER DRAIN VERTICAL

**PRODUCT CODE:** 10299090

---



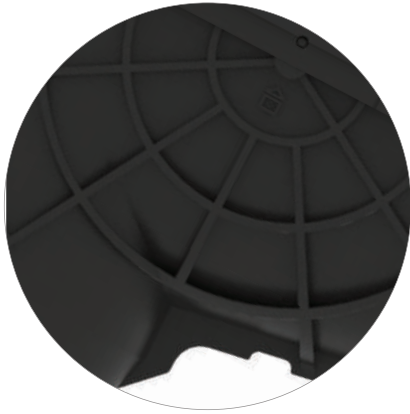

Strengthened ribs for the better adhesion to the base (concrete)



Biggs for cutting appropriate gutter diameter



Valve for protection against pest entrances



#### LEAF CATCHER

The leaf catcher has improved water flow thanks to the central ribbed pillar which in the case of clogging the bottom, provides undisturbed water flow.

The folding handle provides easy removal of catchers and easier disposal of collected leaves. The cup with a conic shape provides easy removal without getting stuck.



# CONTENT

3	ABOUT PEŠTAN
7	TYPES OF PIPING SOLUTION
9	<b>WATER &amp; HEATING</b>
11	FLUIDTHERM
51	PERT-AL-PERT
57	PE-RT OXY
61	HDPE WATER PIPES
65	HDPE RC WATER PIPES
81	ARMO WATER PIPES
93	HDPE GAS PIPES
97	<b>SEWAGE</b>
99	PVC PIPES - 3P
103	HT (PP) PIPES
115	S-LINE
137	PVC (KG) PIPES
153	PP CORUGATED ID PIPES
167	PP CORUGATED OD PIPES
171	HDPE CORRUGATED ID PIPES
179	HDPE CORRUGATED OD PIPES

185	PP STRONG
207	PVC ULTRA
215	PP AND PE SPIROPIPE
222	HDPE PIPES FOR SEWAGE
226	MANHOLES
240	CONCRETE MANHOLES
252	<b>DRAINAGE</b>
254	HDPE OD DRAINAGE PIPES
260	HDPE ID DRAINAGE PIPES
266	PP ID DRAINAGE PIPES
272	PVC DRAINAGE PIPES
280	<b>CABLE PROTECTION</b>
282	SINGLE LAYER CORRUGATED PIPES
286	PVC PTT AND EL-EN PIPES
290	HDPE CORRUGATED CABLE PROTECTION PIPES
292	SMOOTH PIPES FOR CABLE PROTECTION
296	<b>OUTDOOR DRAINAGE</b>
298	VEDRO OUTDOOR DRAIN
302	VEDRO GUTTER DRAIN



## По вопросам продаж и поддержки обращайтесь:

Алматы (7273)495-231  
Ангарск (3955)60-70-56  
Архангельск (8182)63-90-72  
Астрахань (8512)99-46-04  
Барнаул (3852)73-04-60  
Белгород (4722)40-23-64  
Благовещенск (4162)22-76-07  
Брянск (4832)59-03-52  
Владивосток (423)249-28-31  
Владикавказ (8672)28-90-48  
Владимир (4922)49-43-18  
Волгоград (844)278-03-48  
Вологда (8172)26-41-59  
Воронеж (473)204-51-73  
Екатеринбург (343)384-55-89

Иваново (4932)77-34-06  
Ижевск (3412)26-03-58  
Иркутск (395)279-98-46  
Казань (843)206-01-48  
Калининград (4012)72-03-81  
Калуга (4842)92-23-67  
Кемерово (3842)65-04-62  
Киров (8332)68-02-04  
Коломна (4966)23-41-49  
Кострома (4942)77-07-48  
Краснодар (861)203-40-90  
Красноярск (391)204-63-61  
Курск (4712)77-13-04  
Курган (3522)50-90-47  
Липецк (4742)52-20-81

Магнитогорск (3519)55-03-13  
Москва (495)268-04-70  
Мурманск (8152)59-64-93  
Набережные Челны (8552)20-53-41  
Нижегород (831)429-08-12  
Новокузнецк (3843)20-46-81  
Ноябрьск (3496)41-32-12  
Новосибирск (383)227-86-73  
Омск (3812)21-46-40  
Орел (4862)44-53-42  
Оренбург (3532)37-68-04  
Пенза (8412)22-31-16  
Петрозаводск (8142)55-98-37  
Псков (8112)59-10-37  
Пермь (342)205-81-47

Ростов-на-Дону (863)308-18-15  
Рязань (4912)46-61-64  
Самара (846)206-03-16  
Санкт-Петербург (812)309-46-40  
Саратов (845)249-38-78  
Севастополь (8692)22-31-93  
Саранск (8342)22-96-24  
Симферополь (3652)67-13-56  
Смоленск (4812)29-41-54  
Сочи (862)225-72-31  
Ставрополь (8652)20-65-13  
Сургут (3462)77-98-35  
Сыктывкар (8212)25-95-17  
Тамбов (4752)50-40-97  
Тверь (4822)63-31-35

Тольятти (8482)63-91-07  
Томск (3822)98-41-53  
Тула (4872)33-79-87  
Тюмень (3452)66-21-18  
Ульяновск (8422)24-23-59  
Улан-Удэ (3012)59-97-51  
Уфа (347)229-48-12  
Хабаровск (4212)92-98-04  
Чебоксары (8352)28-53-07  
Челябинск (351)202-03-61  
Череповец (8202)49-02-64  
Чита (3022)38-34-83  
Якутск (4112)23-90-97  
Ярославль (4852)69-52-93

Россия +7(495)268-04-70

Казахстан +7(7172)727-132

Киргизия +996(312)96-26-47

почта: [pad@nt-rt.ru](mailto:pad@nt-rt.ru) || сайт: <https://pestan.nt-rt.ru/>